

# GV-Video Server

## *User's Manual*



Before attempting to connect or operate this product, please read these instructions carefully and save this manual for future use.



© 2009 GeoVision, Inc. All rights reserved.

Under the copyright laws, this manual may not be copied, in whole or in part, without the written consent of GeoVision.

Every effort has been made to ensure that the information in this manual is accurate. GeoVision is not responsible for printing or clerical errors.

GeoVision, Inc.  
9F, No. 246, Sec. 1, Neihu Rd.,  
Neihu District, Taipei, Taiwan  
Tel: +886-2-8797-8377  
Fax: +886-2-8797-8335  
<http://www.geovision.com.tw>

Trademarks used in this manual: *GeoVision*, the *GeoVision* logo and *GV* series products are trademarks of GeoVision, Inc. *Windows* and *Windows XP* are registered trademarks of Microsoft Corporation.

October 2009

# Preface

Welcome to the *GV-Video Server User's Manual*.

The GV-Video Server has a series of models designed to meet different needs. Each model has its own firmware that can only be used on the specific model. This Manual is designed for the following models and firmware version:

Model	Firmware Version
GV-VS02	1.46
GV-VS02A	1.01
GV-VS04A	1.0
GV-VS12	1.02

For the users of GV-VS02, please note certain functions are only available for the units of **hardware version 2.0** or **firmware version 1.46**.

This Manual provides an overview of the GV-Video Server and its accessories. The instructions will guide you through the installation and use of the GV-Video Server as well.

# Contents

<b>Chapter 1</b>	<b>Introduction .....</b>	<b>1</b>
1.1	Packing List.....	1
1.1.1	GV-VS02.....	1
1.1.2	GV-VS02A .....	1
1.1.3	GV-VS12.....	2
1.1.4	GV-VS04A .....	2
1.2	System Requirement.....	3
1.3	PoE Support.....	3
1.4	GPS Support .....	3
1.5	Options.....	4
1.6	Physical Description.....	5
1.6.1	Front View.....	5
1.6.2	Rear View .....	9
<b>Chapter 2</b>	<b>Getting Started .....</b>	<b>13</b>
2.1	Installing on a Network.....	13
2.2	Assigning an IP Address .....	13
2.3	Configuration Basics .....	15
<b>Chapter 3</b>	<b>Accessing the GV-Video Server .....</b>	<b>16</b>
3.1	Accessing Your Surveillance Images.....	16
3.2	Functions Featured on the Main Page .....	17
3.2.1	The Live View Window.....	17
3.2.2	The Control Panel of the Live View Window.....	19
3.2.3	Snapshot of a Live Video .....	20
3.2.4	Video Recording .....	20
3.2.5	Picture-in-Picture and Picture-and-Picture View.....	20
3.2.6	Alarm Notification.....	23
3.2.7	Video and Audio Configuration .....	24
3.2.8	Remote Configuration .....	24
3.2.9	Camera Name Display.....	25
3.2.10	Image Enhancement.....	25
3.2.11	PTZ Control.....	26
3.2.12	Visual PTZ .....	27

3.2.13	I/O Control.....	28
3.2.14	Visual Automation.....	29
3.2.15	Network Status.....	29

## **Chapter 4 Administrator Mode .....30**

4.1	Video & Motion.....	32
4.1.1	Multicast.....	32
4.1.2	Video Settings.....	34
4.1.3	Motion Detection.....	38
4.1.4	Privacy Mask.....	39
4.1.5	Text Overlay.....	40
4.1.6	Tampering Alarm.....	41
4.1.7	Visual Automation.....	43
4.1.8	Video Channel Source Settings.....	44
4.2	Digital I/O & PTZ.....	45
4.2.1	PTZ Settings.....	45
4.2.2	Input/Output Settings.....	46
4.2.3	GPS/Wiegand.....	48
4.2.4	Buzzer.....	50
4.3	Events & Alerts.....	51
4.3.1	E-mail.....	51
4.3.2	FTP.....	53
4.3.3	Center V2.....	55
4.3.4	VSM.....	57
4.3.5	GV-GIS.....	59
4.3.6	Backup Center.....	61
4.3.7	Video Gateway.....	63
4.3.8	ViewLog Server.....	64
4.3.9	3GPP.....	64
4.4	Monitoring.....	65
4.5	Recording Schedule.....	66
4.5.1	Recording Schedule Settings.....	66
4.5.2	I/O Monitoring Settings.....	67
4.6	Remote ViewLog.....	67
4.7	Network.....	68
4.7.1	LAN.....	68
4.7.2	Wireless-Client Mode.....	70
4.7.3	Advanced TCP/IP.....	72

4.7.4	UMTS.....	74
4.7.5	Multicast.....	75
4.7.6	IP Filter.....	77
4.8	Management .....	78
4.8.1	Date and Time Settings .....	78
4.8.2	GPS Maps Settings.....	80
4.8.3	Storage Settings .....	81
4.8.4	User Account .....	83
4.8.5	Log Information.....	84
4.8.6	System Log.....	84
4.8.7	Tools .....	86
 <b>Chapter 5 Recording and Playback .....</b>		<b>87</b>
5.1	Recording.....	87
5.2	Playback.....	87
5.2.1	Playback Using USB Mass Storage Device.....	88
5.2.2	Playback Using Remote ViewLog.....	89
5.2.3	Playback of GPS Tracks .....	90
5.2.4	Playback of Daylight Saving Time Events .....	92
 <b>Chapter 6 Advanced Applications .....</b>		<b>93</b>
6.1	Upgrading System Firmware.....	93
6.1.1	Using the Web Interface .....	94
6.1.2	Using the IP Device Utility.....	95
6.2	Backing Up and Restoring Settings.....	96
6.2.1	Backing Up the Settings.....	96
6.2.2	Restoring the Settings.....	97
6.3	GPS Tracking .....	98
6.4	Restoring to Factory Default Settings.....	100
6.5	Verifying Watermark.....	101
6.5.1	Accessing AVI Files .....	101
6.5.2	Running Watermark Proof .....	101
6.5.3	The Watermark Proof Window.....	102
 <b>Chapter 7 DVR Configurations .....</b>		<b>103</b>
7.1	Setting Up IP Cameras .....	104

7.2	Receiving Cardholder Data from Video Server .....	108
7.3	Remote Monitoring with Multi View .....	109
7.4	Remote Monitoring with E-Map .....	111
<b>Chapter 8 CMS Configurations.....</b>		<b>113</b>
8.1	Center V2 .....	113
8.2	VSM .....	115
8.3	Dispatch Server.....	116
<b>Chapter 9 Auxiliary Device Connectors .....</b>		<b>117</b>
9.1	GV-VS02, GV-VS02A and GV-VS04A.....	117
9.1.1	Pin Assignment.....	117
9.1.2	Relay Output.....	118
9.2	GV-VS12 .....	119
9.2.1	Pin Assignment.....	119
9.2.2	RS-232 Terminal Block.....	120
<b>Chapter 10 Mobile Phone Connection .....</b>		<b>121</b>
10.1	PDA.....	122
10.1.1	Installing GView V2.....	122
10.1.2	Activating the GView Function.....	122
10.1.3	Connecting to GV-Video Server.....	123
10.1.4	Playing Back the Recordings from GV-Video Server.....	124
10.1.5	Other Functions .....	125
10.2	Windows Smartphone .....	130
10.2.1	Installing MSView V2 / V3.....	130
10.2.2	Activating the MSView V2 / V3 Function.....	130
10.2.3	Connecting to GV-Video Server.....	130
10.2.4	Playing Back the Recordings from GV-Video Server.....	132
10.2.5	Other Functions .....	132
10.3	Symbian Smartphone.....	133
10.3.1	Installing SSVIEW V3.....	133
10.3.2	Activating the SSVIEW V3 Function.....	134
10.3.3	Connecting to GV-Video Server.....	134
10.3.4	Quick Connection.....	135
10.3.5	Playing Back the Recordings from GV-Video Server.....	135

10.3.6 Other Functions .....	135
10.4 3G Mobile Phone .....	136
10.4.1 Activating the 3G Mobile Phone Function.....	136
10.4.2 Connecting to the GV-Video Server.....	136

## **Specifications .....138**

Video .....	138
Audio .....	138
Management .....	138
Network .....	139
Power over Ethernet .....	139
Connector.....	139
Alarm.....	139

## **Appendix .....141**

A. Supported Wireless LAN USB Adaptor .....	141
B. Supported Mobile Broadband Device.....	141
C. Settings for Internet Explore 8.....	142



# Chapter 1 Introduction

The GV-Video Server, including the models GV-VS02, GV-VS02A, GV-VS04A and GV-VS12, allows the conversion of any analog camera into a fully functional IP camera. It streams the real-time digital video over the Internet in the same way that current IP cameras do. With the analog cameras attached to the GV-Video Server, you can see camera images through a web browser anytime and anywhere. And with the GV-Video Server connected to the GV-System, your existing surveillance system can be upgraded and networked into a new IP surveillance system.

## 1.1 Packing List

### 1.1.1 GV-VS02



Figure 1-1

1. AC Power Cord x 1
2. DC Male-to-Male Connector x 1
3. Power Adaptor x 1
4. Wall Hook x 1
5. Conical Anchor x 4
6. Screw x 4
7. GV-Video Server Software DVD x 1
8. GV-Video Server User's Manual x 1

### 1.1.2 GV-VS02A



Figure 1-2

1. AC Power Cord x 1
2. DC Male-to-Male Connector x 1
3. Power Adaptor x 1
4. Wall Hook x 1
5. Conical Anchor x 4
6. Screw x 4
7. GV-Video Server Software DVD x 1
8. GV-Video Server User's Manual x 1

### 1.1.3 GV-VS12



Figure 1-3

1. AC Power Cord x 1
2. Power Adaptor x 1
3. I/O Cable with RJ-45 Connector x 1
4. Wall Hook x 1
5. Conical Anchor x 2
6. Screw x 4
7. Sticker (for positioning conical anchors) x 1
8. GV-Video Server Software DVD x 1
9. GV-Video Server User's Manual x 1

### 1.1.4 GV-VS04A



Figure 1-4

1. AC Power Cord x 1
2. DC Male-to-Male Connector x 1
3. Power Adaptor x 1
4. Wall Hook x 1
5. Conical Anchor x 4
6. Screw x 4
7. 3.5 mm Stereo to RCA Cable x 2
8. GV-Video Server Software DVD x 1
9. GV-Video Server User's Manual x 1
10. DC 1 Male to 4 Female Cable (for camera power supply from the GV-Video Server) -----Optional

## 1.2 System Requirement

Microsoft Internet Explorer 6.x or later

---

**Note:** For the users of **Internet Explorer 8**, it is required to configure the Security Settings. Without the settings, you cannot access the GV-Video Server. See *Appendix C*.

---

## 1.3 PoE Support

The models supporting PoE (Power over Ethernet) include:

- GV-VS02 (Hardware Version 2.0), GV-VS02A, GV-VS12 and GV-VS04A.

When the PoE (Power over Ethernet) function is used, please note:

- The I/O terminal functions cannot work. Don't connect any devices to the I/O terminal block on the rear panel of the unit.
- External power supply is required for USB storage device when used for recording.

See "Power over Ethernet" in *Specifications* later in this manual before purchasing a PoE adaptor.

## 1.4 GPS Support

Attached with the GPS receiver, the GV-Video Server allows you to perform vehicle tracking on Google Maps. The models supporting GPS function include:

- GV-VS02 (Hardware Version 2.0), GV-VS02A, GV-VS12 and GV-VS04A

The GV-GPS Receiver comes in two types of interfaces, UART and RS-232. Different models of the GV-Video Server support different interfaces.

- **UART:** GV-VS02 (Hardware Version 2.0), GV-VS02A and GV-VS04A
- **RS-232:** GV-VS12

## 1.5 Options

Optional devices can expand your GV-Video Server's capabilities and versatility. Contact your dealer for more information.

<b>GV-GPS Receiver</b>	GV-GPS Receiver is a Global Position System receiver, allowing you to perform vehicle tracking and location verification functions. It is available in two types of interfaces: UART and RS-232.
<b>GV-Reader</b>	GV-Reader includes transmit-receive antenna and electronics. With both Wiegand and RS-485 outputs, it is compatible with any standard access control panel.
<b>GV-Relay V2</b>	Working with this module, GV-Video Server can drive the loads of relay outputs over 5 volts.
<b>GV-Storage System</b>	The iSCSI storage system allows you to record files over the Internet.

## 1.6 Physical Description

This section identifies the various components of the GV-Video Server.

### 1.6.1 Front View

#### 1.6.1.1 GV-VS02

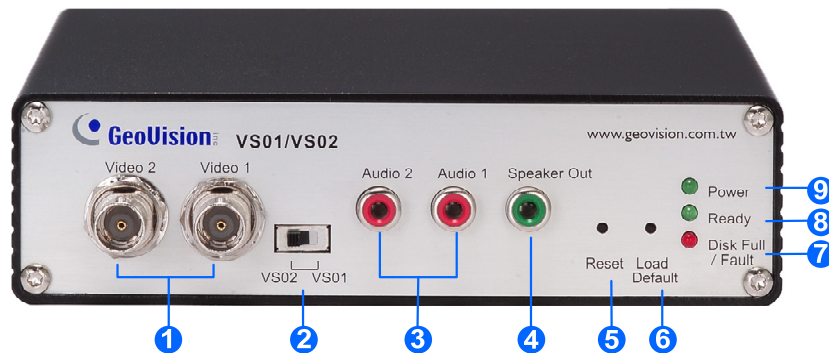

Figure 1-5

No.	Name	Function
1	Video Input	2 plugs for video inputs.
2	Video Stream Switch	The switch is designed for 2 cameras mode in live view. When the switch is set in <b>VS01</b> , dual streams of Video 1 are displayed. <b>VS02</b> , Video 1 and Video 2 are displayed simultaneously. Ensure to reboot the GV-Video Server after changing the setup.
3	Audio Input	2 plugs for audio inputs.
4	Speaker Output	A plug for the speaker device.
5	Reset Button	It reboots the GV-Video Server, and keeps all current configurations.
6	Default Button	It resets all configurations to their factory settings. See 6.4 <i>Restoring to Factory Default Settings</i> .
7	Disk Full/Fault LED	This LED is on, indicating the hard drive is full or faulty.
8	Ready LED	This LED is on, indicating the GV-Video Server is ready for connection.
9	Power LED	This LED is on, indicating the power is supplied.

### 1.6.1.2 GV-VS02A



Figure 1-6

No.	Name	Function
1	Video Input	2 plugs for video inputs.
2	Audio Input	2 plugs for audio inputs.
3	Speaker Output	A plug for the speaker device.
4	Reset Button	It reboots the GV-Video Server, and keeps all current configurations.
5	Default Button	It resets all configurations to their factory settings. See 6.4 <i>Restoring to Factory Default Settings</i> .
6	Disk Full/Fault LED	This LED is on, indicating the hard drive is full or faulty.
7	Ready LED	This LED is on, indicating the GV-Video Server is ready for connection.
8	Power LED	This LED is on, indicating the power is supplied.

1.6.1.3 GV-VS12



Figure 1-7

No.	Name	Function
1	USB Port	1 USB port for installing the portable storage device.
2	Speaker Output	A plug for the speaker device.
3	Audio Input	2 plugs for audio inputs.
4	Video Input	2 plugs for video inputs.

### 1.6.1.4 GV-VS04A



Figure 1-8

No.	Name	Function
1	Video Input	4 plugs for video inputs.
2	Speaker Output	A plug for the speaker device.
3	Audio Input	Each plug is for 2 audio inputs.
4	Reset	It reboots the GV-Video Server, and keeps all current configurations.
5	Default Button	It resets all configurations to their factory settings. See 6.4 <i>Restoring to Factory Default Settings</i> .
6	Disk Full/Fault LED	This LED is on, indicating the hard drive is full or faulty.
7	Ready LED	This LED is on, indicating the GV-Video Server is ready for connection.
8	Power LED	This LED is on, indicating the power is supplied.



## 1.6.2 Rear View

### 1.6.2.1 GV-VS02

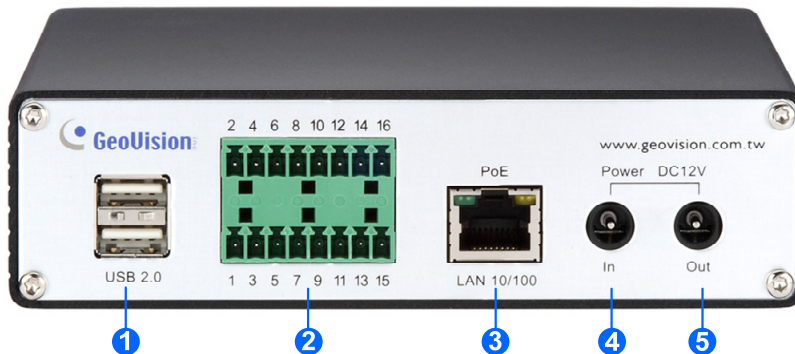

Figure 1-9

No.	Name	Function
1	USB Port	2 USB ports for installing portable storage devices.
2	Ethernet Port	A plug for inserting an Ethernet cable to build the network connection.
3	Terminal Block	The connectors for digital input, relay output, PTZ camera, Wiegand device and GPS module control. See <i>Chapter 9 Auxiliary Device Connectors</i> . Note the GPS function is only available on GV-VS02 (Hardware Version 2.0).
4	Power In	A plug for power input.
5	Power Out	A plug for power output. This power out can be used to power on cameras with a DC male to female power splitter cable (which is an optional cable).

### 1.6.2.2 GV-VS02A

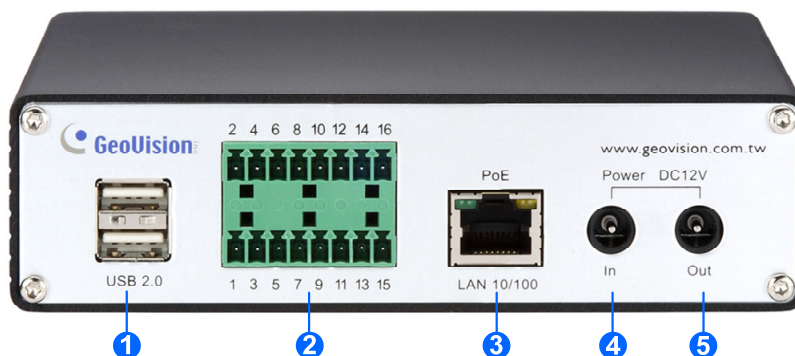

Figure 1-10

No.	Name	Function
1	USB Port	2 USB ports for installing portable storage devices.
2	Terminal Block	The connectors for digital input, relay output, PTZ camera, Wiegand device and GPS module control. See <i>Chapter 9 Auxiliary Device Connectors</i> .
3	Ethernet Port	A plug for inserting an Ethernet cable to build the network connection.
4	Power In	A plug for power input.
5	Power Out	A plug for power output. This power out can be used to power on cameras by using a DC male to female power splitter cable (which is not supplied).

1.6.2.3 GV-VS12

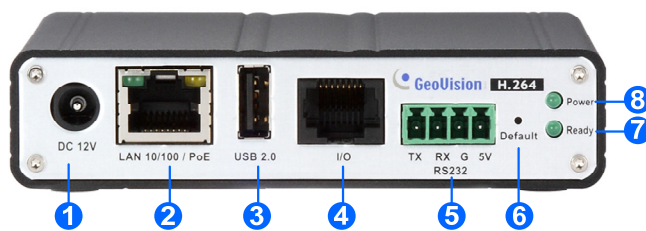

Figure 1-11

No.	Name	Function
1	Power In	A plug for power input.
2	Ethernet Port	A plug for inserting an Ethernet cable to build the network connection.
3	USB Port	1 USB port for installing the portable storage device.
4	I/O / PTZ Port	A port for digital input, relay output and PTZ camera control. Insert the I/O Cable with RJ-45 Connector to this port. See <i>Chapter 9 Auxiliary Device Connectors</i> .
5	RS-232 Terminal Block	The connectors for GPS module control. See <i>Chapter 9 Auxiliary Device Connectors</i> .
6	Default Button	It resets all configurations to their factory settings. See <i>6.4 Restoring to Factory Default Settings</i> .
7	Ready LED	This LED is on, indicating the GV-Video Server is ready for connection.
8	Power LED	This LED is on, indicating the power is supplied.

### 1.6.2.4 GV-VS04A

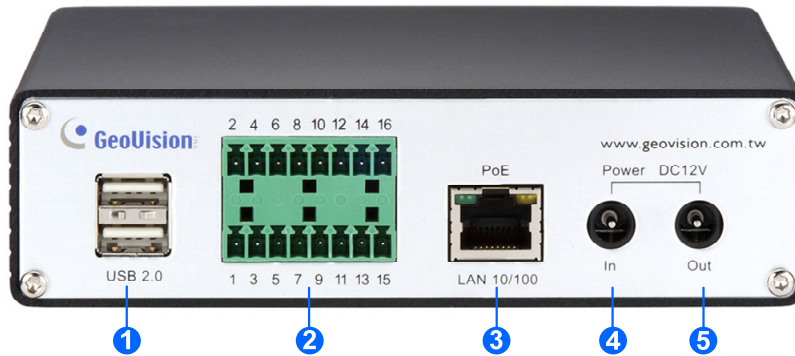

Figure 1-12

No.	Name	Function
1	USB Port	2 USB ports for installing portable storage devices.
2	Terminal Block	The connectors for digital input, relay output, PTZ camera, Wiegand device and GPS module control. See <i>Chapter 9 Auxiliary Device Connectors</i> .
3	Ethernet Port	A plug for inserting an Ethernet cable to build the network connection.
4	Power In	A plug for power input.
5	Power Out	A plug for power output. This power out can be used to power on cameras by using a DC male to female power splitter cable (which is an optional accessory).

# Chapter 2 Getting Started

This section provides basic information to get the GV-Video Server working on the network.

## 2.1 Installing on a Network

These instructions describe the basic connections to install the GV-Video Server on the network. Here we use GV-VS02 as the example to demonstrate the steps.

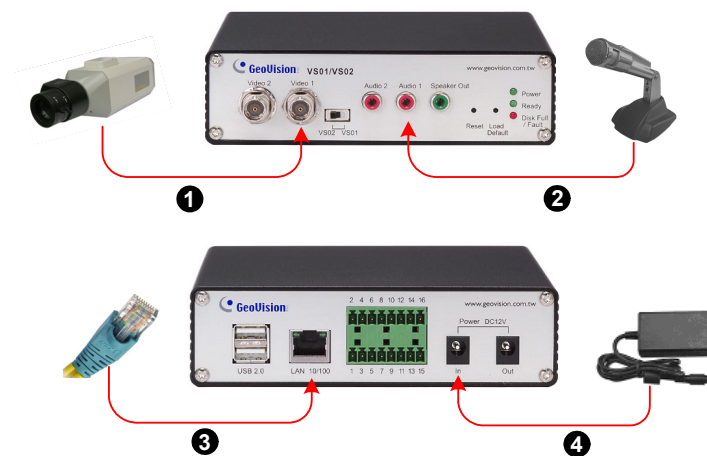

Figure 2-1

1. Connect your camera's video output to the BNC video input.
2. Connect your audio source to the RCA audio input.
3. Connect the hub or switch on the LAN to the unit's 10/100 Mbps port.
4. Connect the power supply to the power input.
5. Wait until both Power and Ready LEDs are on and then you can set the IP address for the unit.

## 2.2 Assigning an IP Address

Designed for use on the network, the GV-Video Server must be assigned an IP address to make it accessible.

---

**Note:** The GV-Video Server has a default address of **192.168.0.10**. The computer used to set the IP address must be under the same network or IP sequence assigned to the unit.

---

1. Open your web browser, and type the default IP address <http://192.168.0.10>
2. In both Login and Password fields, type the default value **admin**. Click **Apply**.
3. In the left menu, select **Network** and then **LAN** to begin the network settings.

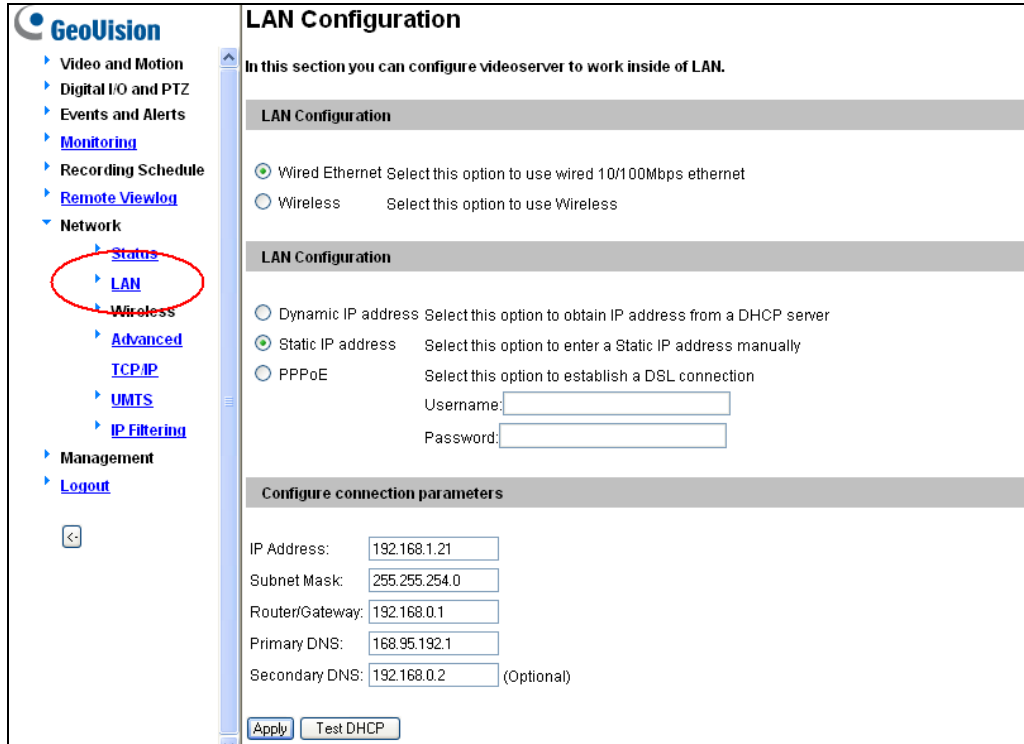

Figure 2-2

4. Select **Static IP address**. Type IP Address, Subnet Mask, Router/Gateway, Primary DNS and Secondary DNS in the **Configure connection parameters** section.
5. Click **Apply**. The GV-Video Server is accessible by entering the assigned IP address on the web browser.

#### IMPORTANT:

- **Dynamic IP Address** and **PPPoE** should only be enabled if you know which IP address the GV-Video Server will get from the DHCP server or ISP. Otherwise, you must use the Dynamic DNS service to obtain a domain name linked to the GV-Video Server's changing IP address first.

For details on Dynamic DNS Server settings, see *4.7.3 Advanced TCP/IP*.

- If **Dynamic IP Address** and **PPPoE** is enabled and you cannot access the unit, you may have to reset it to the factory default settings and then perform the network settings again.

To restore the factory settings, see the **Default** button in *1.5.1 Front View*.

## 2.3 Configuration Basics

Once the GV-Video Server is properly installed, the following important features can be configured using the browser-based configuration page and are discussed in the following sections in this manual:

- **Date and time adjustment:** see *4.8.1 Date and Time Settings*.
- **Login and privileged passwords:** see *4.8.4 User Account*.
- **Network gateway:** see *4.7 Network*.
- **Camera image adjustment:** see *3.2.2 The Control Panel of the Live View Window*.
- **Video format, resolution and frame rate:** see *4.1.2 Video Settings*.

## Chapter 3 Accessing the GV-Video Server

Two types of users are allowed to log in the GV-Video Server: **Administrator** and **Guest**. The Administrator has unrestricted access to all system configurations, while the Guest has the access to live images and network status only.

### 3.1 Accessing Your Surveillance Images

Once installed, your GV-Video Server is accessible on a network. Follow these steps to access your surveillance images:

1. Start the Internet Explorer browser.
2. Enter the IP address or domain name of the GV-Video Server in the **Location/Address** field of your browser.

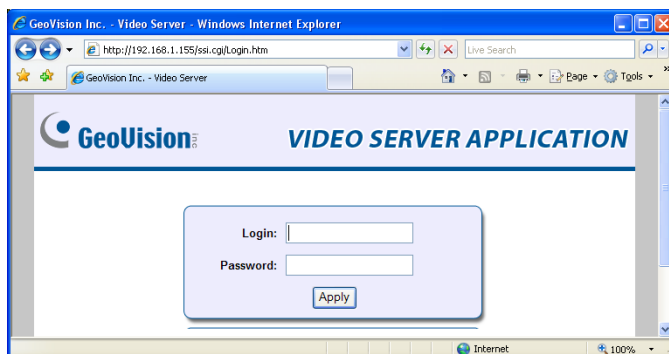

Figure 3-1

3. Enter the login name and password.
  - The default login name and password for Administrator are **admin**.
  - The default login name and password for Guest are **guest**.
4. A video image, similar to the example in Figure 3-2, is now displayed in your browser.

---

**Note:** To enable the updating of images in Microsoft Internet Explorer, you must set your browser to allow ActiveX Controls and perform a once-only installation of GeoVision's ActiveX component onto your computer.

---



## 3.2 Functions Featured on the Main Page

This section introduces the features of the **Live View** window and **Network Status** on the main page. The two features are accessible by both Administrator and Guest.

### Main Page of Guest Mode

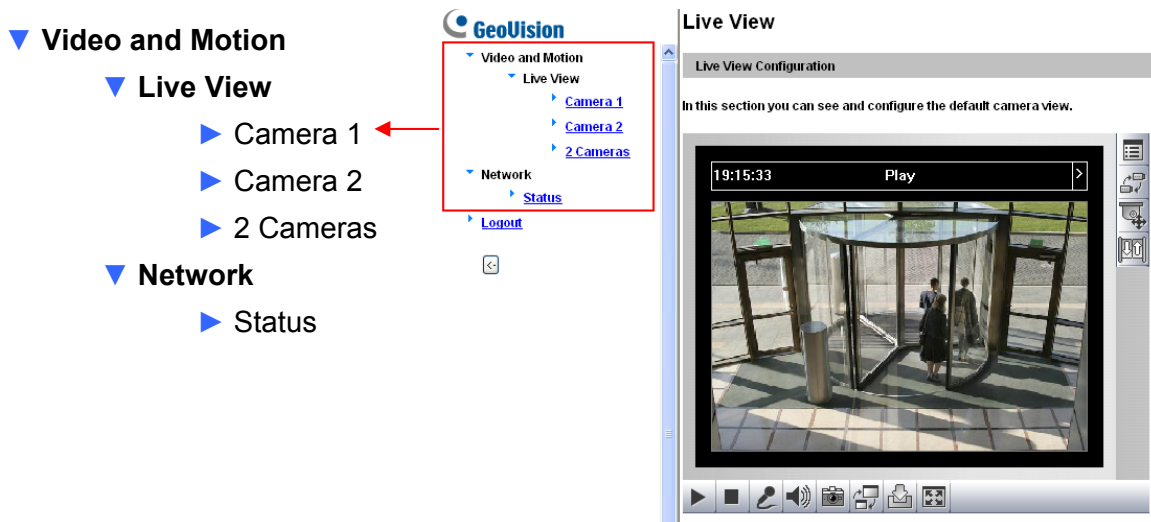

Figure 3-2

### 3.2.1 The Live View Window

In the left menu, click **Live View**, and then select **Camera 1**, **Camera 2** or **2 Cameras** to see the live video.

---

**Note:** To have the dual streaming of Camera 1, the Video Stream Switch on the unit should be set to VS01. Note this function is only available on GV-VS02.

---

## Live View

### Live View Configuration

In this section you can see and configure the default camera view.



Figure 3-3

No.	Name	Function
1	Play	Plays live video.
2	Stop	Stop playing video.
3	Microphone	Talks to the surveillance area from the local computer.
4	Speaker	Listens to the audio around the camera.
5	Snapshot	Takes a snapshot of live video. --- See 3.2.3 <i>Snapshot of a Live Video</i> .
6	File Save	Records live video to the local computer. --- See 3.2.4 <i>Video Recording</i> .
7	Full Screen	Switches to full screen view. Right-click the image to have these options: <b>Snapshot</b> , <b>PIP</b> , <b>PAP</b> , <b>Zoom In</b> and <b>Zoom Out</b> . --- See 3.2.5 <i>Picture-in-Picture and Picture-and-Picture View</i> .
8	I/O Control	Starts the I/O Control Panel or the Visual Automation. --- See 3.2.13 <i>I/O Control</i> .
9	PTZ Control	Starts the PTZ Control Panel and the Visual PTZ. --- See 3.2.11 <i>PTZ Control</i> and 3.2.12 <i>Visual PTZ</i> .
10	Change Camera	Sets the desired camera for display.
11	Show System Menu	Brings up these functions: <b>Alarm Notify</b> , <b>Video and Audio Configuration</b> , <b>Remote Config</b> , <b>Show Camera Name</b> and <b>Image Enhance</b> . --- See 3.2.6 <i>Alarm Notification</i> , 3.2.7 <i>Video and Audio Configuration</i> , 3.2.8 <i>Remote Configuration</i> , 3.2.9 <i>Camera Name Display</i> and 3.2.10 <i>Image Enhancement</i> respectively.

### 3.2.2 The Control Panel of the Live View Window

To open the control panel of the Live View window, click the arrow button on top of the viewer. You can access the following functions by using the right and left arrow buttons on the control panel.

Click the arrow button to display the control panel.

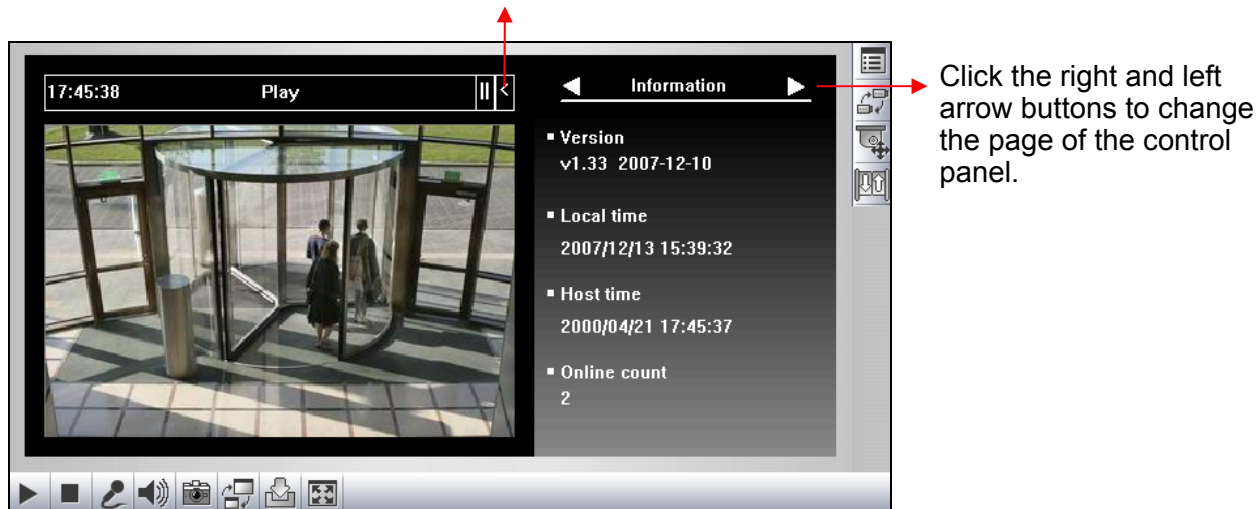

Figure 3-4

**[Information]** Displays the version of the Video Server, local time of the local computer, host time of the Video Server, and the number of users logging in to the Video Server.

**[Video]** Displays the current video codec, resolution and data rate.

**[Audio]** Displays the audio data rates when the microphone and speaker devices are enabled.

**[I/O Control]** Provides a real-time graphic display of the input and output status. You can force the output to be triggered by double-clicking its icon.

**[Alarm Notify]** Displays the captured images by sensor triggers and/or motion detection. For this function to work, you must configure the Alarm Notify settings first. See 3.2.6 *Alarm Notification*.

**[Camera Adjustment]** Allows you to adjust the image quality.

**[GPS]** For details see 6.3 *GPS Tracking*.

**[Download]** Allows you to install the programs from the hard drive.

### 3.2.3 Snapshot of a Live Video

To take a snapshot of live video, follow these steps:

1. Click the **Snapshot** button (No. 5, Figure 3-3). The Save As dialog box appears.
2. Specify **Save in**, type the **File name**, and select **JPEG** or **BMP** as **Save as Type**. You may also choose whether to display the name and date stamps on the image.
3. Click the **Save** button to save the image in the local computer.

### 3.2.4 Video Recording

You can record live video for a certain period of time to your local computer.

1. Click the **File Save** button (No. 6, Figure 3-3). The Save As dialog box appears.
2. Specify **Save in**, type the **File name**, and move the **Time Period** scroll bar to specify the time length of the video clip from 1 to 5 minutes.
3. Click the **Save** button to start recording.
4. To stop recording, click the **Stop** button (No. 2, Figure 3-3).

### 3.2.5 Picture-in-Picture and Picture-and-Picture View

The full screen mode provides two types of close-up views: **Picture-in-Picture (PIP)** and **Picture-and Picture (PAP)**. The two views are useful to provide clear and detailed images of the surveillance area.

To access this feature:

- Click the **Full Screen** button (No. 7, Figure 3-3). Right-click the full screen to have the options of **PIP** and **PAP**.
- Right-click the live view to have the options of **PIP** and **PAP**.

### Picture-in-Picture View

With the Picture in Picture (PIP) view, you can crop the video to get a close-up view or zoom in on the video.



Figure 3-5

1. Select **PIP**. An inset window appears.
2. Click the insert window. A navigation box appears.
3. Move the navigation box around in the inset window to have a close-up view of the selected area.
4. To adjust the navigation box size, move the cursor to any of the box corners, and enlarge or diminish the box.
5. To exit the PIP view, right-click the image and click **PIP** again.

## Picture-and-Picture View

With the Picture and Picture (PAP) view, you can create a split video effect with multiple close-up views on the image. A total of 7 close-up views can be defined.



Figure 3-6

1. Select **PAP**. A row of three inset windows appears at the bottom.
2. Draw a navigation box on the image, and this selected area is immediately reflected in one inset window. Up to seven navigation boxes can be drawn on the image.
3. To adjust a navigation box size, move the cursor to any of the box corners, and enlarge or diminish the box.
4. To move a navigation box to another area on the image, drag it to that area.
5. To change the frame color of the navigation box or hide the box, right-click the image, select **Mega Pixel Setting** and click one of these options:
  - **Display Focus Area of PAP Mode:** Displays or hides the navigation boxes on the image
  - **Set Color of Focus Area:** Changes the color of the box frames.
6. To delete a navigation box, right-click the desired box, select **Focus Area of PAP Mode** and click **Delete**.
7. To exit the PAP view, right-click the image and click **PAP** again.

### 3.2.6 Alarm Notification

After input triggers and motion detection, you can be alerted by a pop-up live video and view up to four captured images.



Figure 3-7

To configure this function, click the **Show System Menu** button (No. 11, Figure 3-3), and select **Alarm Notify**. This dialog box appears.

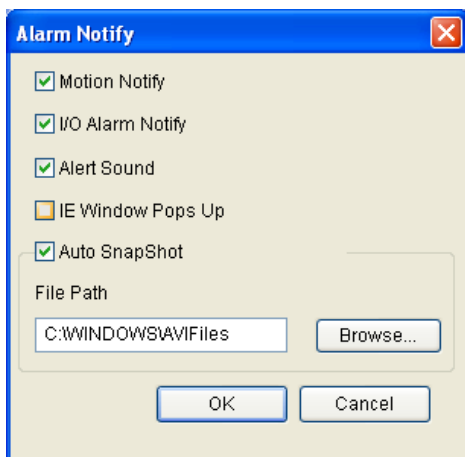

Figure 3-8

- **Motion Notify:** Once motion is detected, the captured images are displayed on the control panel of the Live View window.
- **I/O Alarm Notify:** Once the input device is triggered, the captured images are displayed on the control panel of the Live View window. For this function to work, the Administrator needs to install the input device properly. See *4.2.2 Input/Output Settings*.
- **Alert Sound:** Activates the computer alarm on motion and input-triggered detection.
- **IE Window Pops up:** The minimized Live View window pops up on motion and input-triggered detection.

- **Auto Snapshot:** The snapshot of live video is taken every 5 seconds on motion and input-triggered detection.
- **File Path:** Assigns a file path to save the snapshots.

### 3.2.7 Video and Audio Configuration

You can enable the microphone and speaker for two-way audio communication and adjust the audio volume. To change audio configuration, click the **Show System Menu** button (No. 11, Figure 3-3), and select **Video and Audio Configuration**.

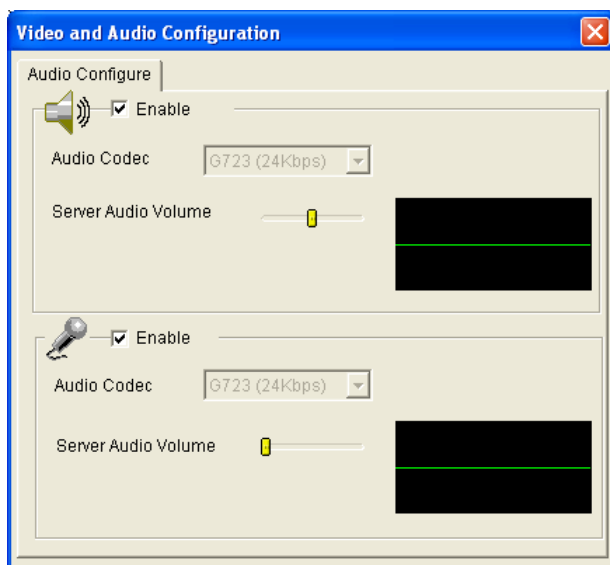

Figure 3-9

### 3.2.8 Remote Configuration

You can view the connection status of the central monitoring stations and upgrade firmware over the Internet. Click the **Show System Menu** button (No. 11, Figure 3-3), and select **Remote Config**. The Remote Config dialog box will appear.

**[Status]** In this tab, you can see the current status of the connection to Center V2 and VSM.

**[Firmware Upgrade]** In this tab, you can upgrade the firmware over the network. For details, see *Chapter 6 Advanced Applications*.



### 3.2.9 Camera Name Display

To display the camera name on the image, click the **Show System Menu** button (No. 11, Figure 3-3), and select **Show Camera Name**.

### 3.2.10 Image Enhancement

To enhance the image quality of live video, click the **Show System Menu** button (No. 11, Figure 3-3), and select **Image Enhance**. This dialog box appears.

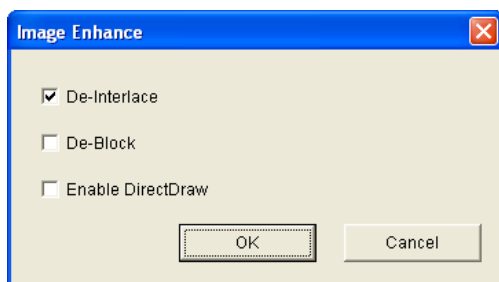

*Figure 3-10*

- **De-Interlace:** Converts the interlaced video into non-interlaced video.
- **De-Block:** Removes the block-like artifacts from low-quality and highly compressed video.
- **Enable DirectDraw:** Activates the DirectDraw function.

### 3.2.11 PTZ Control

To open the PTZ control panel, click the **PTZ Control** button (No. 9, Figure 3-3) and select **PTZ Control Panel**. Different PTZ devices have different functions, so the features included in the **Option** button may vary.

This feature is only available when the PTZ is set ahead by the Administrator. For details, see *4.2.1 PTZ Settings*.

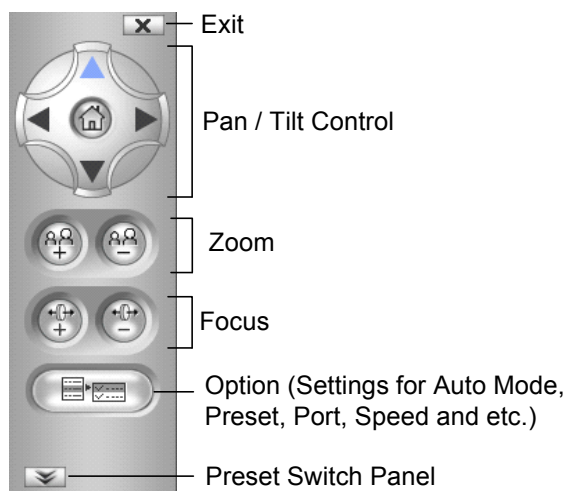

Figure 3-11

### 3.2.12 Visual PTZ

In addition to the PTZ control panel, you can display a visual PTZ control panel on the image. This feature is only available when the PTZ is set ahead by the Administrator. For details, see 4.2.1 PTZ Settings.



Figure 3-12

- To access this feature, click the **PTZ Control** button (No. 9, Figure 3-3) and select **Visual PTZ**.
- To change the panel settings, click the green **PTZ** button on the top left corner. You will have these options:

#### [PTZ Control Type]

- **Type 1:** In this mode when you place the mouse arrow on the four directions, i.e. north, south, east, west, the speed indicator of five levels will appear. Click and hold on the required level of movement and the camera will move as per the specific speed.
- **Type 2:** In this mode with the mouse click, the PTZ control panel will appear. The movement of the camera will depend on the speed of the mouse movement.

#### [Configure]

- **Set Color:** Changes the color of the panel. Three kinds of colors are available: **Red**, **Green** and **Blue**.
- **Transparent Degree:** Adjusts the transparency level of the panel. Ten levels range from 10% (fully transparent) to 100% (fully opaque).

### 3.2.13 I/O Control

The I/O Control window provides real-time graphic displays of camera and I/O status, and alarm events. Additionally, you can force output to be triggered.

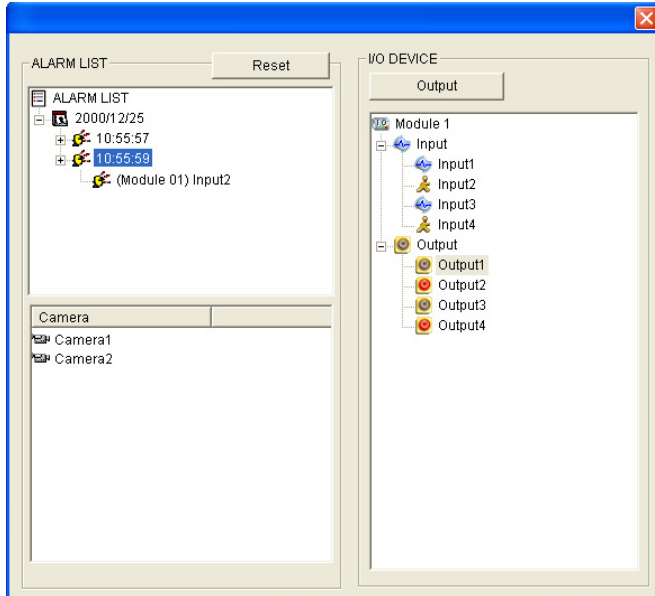

Figure 3-13

- To display the I/O control window, click the **I/O Control** button (No. 8, Figure 3-3).
- The Alarm List is displayed in three levels. The first level indicates date, the second indicates time, and the third indicates alarm ID. Clicking the **Reset** button will clear the list.
- To trigger an output device, highlight an output and then click the **Output** button.

### 3.2.14 Visual Automation

The Visual Automation allows you to change the current state of the electronic device by simply clicking on its image, e.g. turning the light ON. This feature is only available when the Visual Automation is set ahead by the Administrator. For details, see 4.1.7 *Visual Automation*.

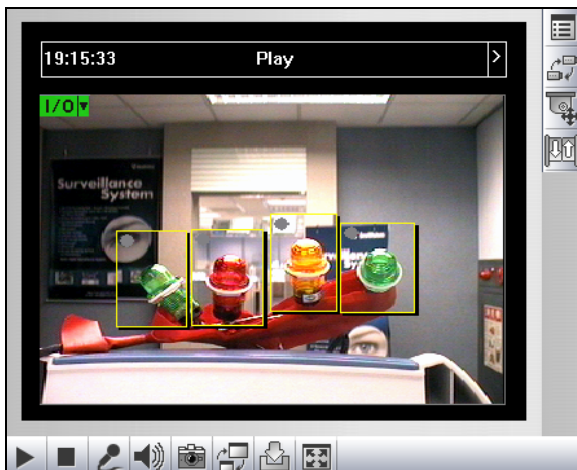

Figure 3-14

- To access this feature, click the **I/O Control** button (No. 8, Figure 3-3) and select **Visual Automation**.
- To change the style of the set areas, click the green **I/O** button on the top left corner. You will have these options:
  - **Show All:** Displays all set areas.
  - **Rect Float:** Embosses all set areas.
  - **Set Color:** Changes the frame color of all set areas

### 3.2.15 Network Status

To view the network status, in the left menu, click **Network** and select **Status**.

Network Status Information	
<b>Current Status Information</b>	
In this section you can see an overview of videosever status.	
Interface:	Wired
Gain IP:	Fixed
MAC Address:	0013E2010351
IP Address:	192.168.0.233
Subnet Mask:	255.255.255.0
Gateway:	192.168.0.1
DNS Server 1:	192.168.0.1
DNS Server 2:	192.168.0.2

Figure 3-15

# Chapter 4 Administrator Mode

The Administrator can access the system configuration via the Internet. Eight categories of configurations are involved in the system configuration: **Video and Motion**, **Digital I/O and PTZ**, **Events and Alerts**, **Monitoring**, **Recording Schedule**, **Remote ViewLog**, **Network**, and **Management**.

- ▼ **Video and Motion**
  - ▶ Live View
  - ▶ Video Settings
  - ▶ Motion Detection
  - ▶ Privacy Mask
  - ▶ Text Overlay
  - ▶ Tampering Alarm
  - ▶ Visual Automation
  - ▶ Video Channel Source Settings
- ▼ **Digital I/O and PTZ**
  - ▶ I/O Control
  - ▶ PTZ Settings
  - ▶ GPS/Wiegand
  - ▶ Buzzer
- ▼ **Events and Alerts**
  - ▶ Email
  - ▶ FTP
  - ▶ Center V2
  - ▶ VSM
  - ▶ GV-GIS
  - ▶ Backup Center
  - ▶ Video Gateway
  - ▶ ViewLog
  - ▶ 3GPP
- ▼ **Monitoring**
- ▼ **Recording Schedule**
  - ▶ Camera
  - ▶ I/O Monitor
- ▼ **Remote ViewLog**
- ▼ **Network**
  - ▶ Status
  - ▶ LAN
  - ▶ Wireless
  - ▶ Advanced TCP/IP
  - ▶ UMTS
  - ▶ Multicast
  - ▶ IP Filtering
- ▼ **Management**
  - ▶ Date and Time
  - ▶ GPS Maps Settings
  - ▶ Storage Settings
  - ▶ User Account
  - ▶ Log Information
- ▶ **Tools**

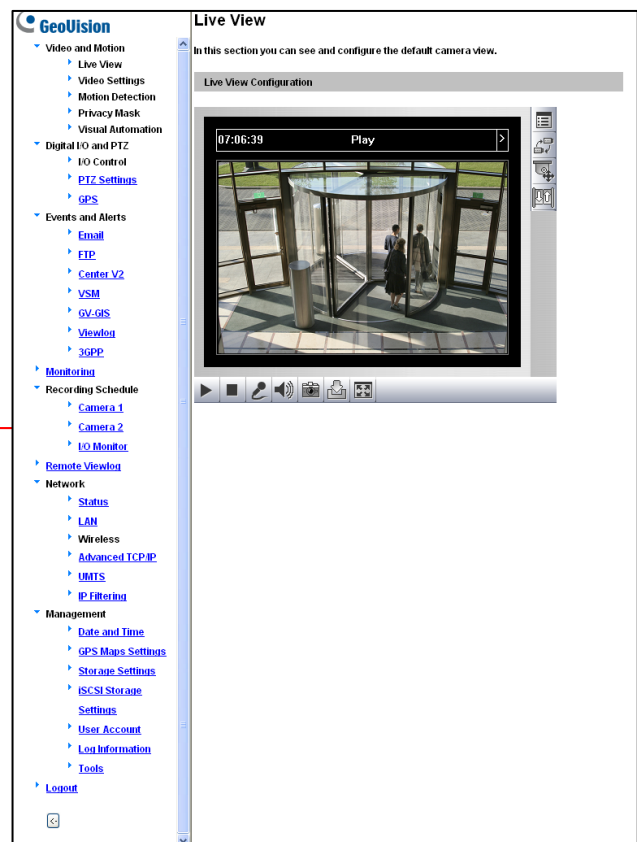

Figure 4-1

**Comparison Table for Major Functions**

The options or functions on the left menu of the Web interface (Figure 4-1) may vary depended on models. The table below provides the information of major differences in supported functions.

<b>Model</b> <b>Function</b>	<b>GV-VS02</b> (Firmware V1.46)	<b>GV-VS02A</b> (Firmware V1.01 or later)	<b>GV-VS04A</b> (Firmware V1.0 or later)	<b>GV-VS12</b> (Firmware V1.02 or later)
<b>Wiegand</b>	Yes	Yes	Yes	No
<b>Buzzer</b>	No	Yes	Yes	No
<b>Multicast</b>	Yes	Yes	Yes	No
<b>Tampering Alarm</b>	No	Yes	Yes	Yes
<b>Watermark</b>	No	Yes	Yes	Yes
<b>Video Channel Source Settings</b>	No	Yes	Yes	No
<b>System Log</b>	No	Yes	Yes	Yes
<b>Backup Center</b>	No	Yes	Yes	Yes
<b>Video Gateway</b>	No	Yes	Yes	Yes
<b>GIS with Two Connections</b>	No	Yes	Yes	Yes
<b>Text Overlay</b>	No	Yes	Yes	Yes
<b>Note:</b> The Watermark option is included in the <b>Video Settings</b> page.				

## 4.1 Video & Motion

This section includes the video image settings and introduces how the images can be managed by using Multicast, Motion Detection, Privacy Mask, Tampering Alarm, Visual Automation and Video Channel Source Settings.

### 4.1.1 Multicast

Note this function is only available on **GV-VS02** (Firmware Version 1.46 or later), **GV-VS02A** (Firmware Version 1.01 or later), **GV-VS04A** and **GV-VS12** (Firmware Version 1.02 or later).

The Multicast view allows the GV-Video Server receiving video and audio streams from a multicast group. It also enables the GV-Video Server to receive audio broadcast from the hosts in the multicast group.

To join a multicast group and listen to audio broadcasting, it is required to activate the related settings in *4.7.5 Multicast*.

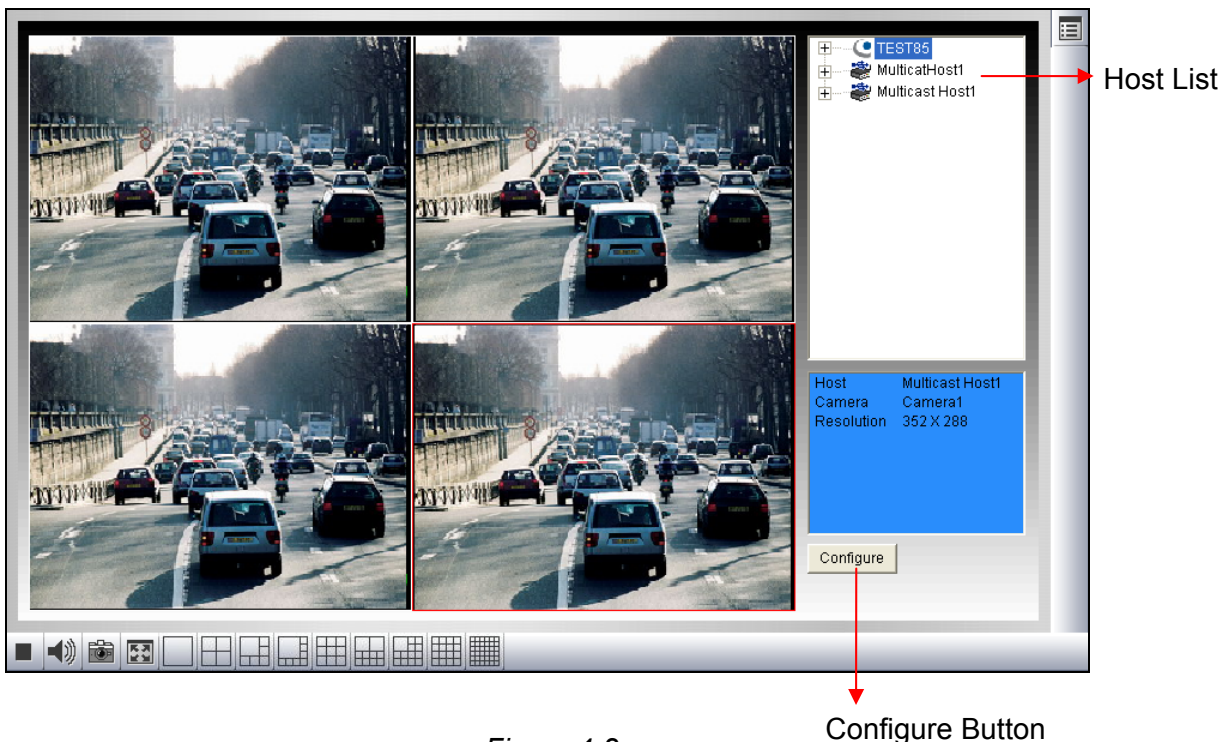

Figure 4-2

1. The host(s), in the multicast group, is displayed automatically on the host list. If you cannot see any host displayed, click the **Configure** button, select **General Setup**, select **Multicast** and ensure the relevant IP address, port number and network card are correctly configured.



2. Expand the Host folder and drag the desired cameras to the screen for display. If the host has already set a password, you will be promoted to enter it at this step.
3. To receive audio broadcasting, first ensure a speaker is properly installed on the local computer. Then click the **Configure** button, select **General Setup**, select **Receive broadcast audio**, and ensure the broadcast IP address and port number are correctly configured.
4. To save the current settings of screen division and camera display for future use, click the **Configure** button, select **Video List Setup**, and select **Export**. You can also select **Import** to apply the pre-defined settings.

## 4.1.2 Video Settings

### Video Settings

In this section you can define compression art, broadcasting method and privacy mask.

**Name**

Name

**Connection template**

**Video Signal Type**

In this section you can configure camera's video signal between NTSC or PAL, also the resolution and frame per second to be transmitted through the network

Main streaming type

Auto detect signal type on booting

	Signal Format	Resolution	Frame per second
<input checked="" type="radio"/>	NTSC	<input type="text" value="360*240"/>	<input type="text" value="30"/>
<input type="radio"/>	PAL	<input type="text" value="360*288"/>	<input type="text" value="25"/>

**Bandwidth Management**

In this section you can configure the bit rate used by MPEG-4 video stream. Using VBR (Variable Bit Rate) is an intelligent method to compensate between image quality and bandwidth control. But if you want to provide consistently the same image quality at bandwidth cost, please set to CBR (Constant Bit Rate).

VBR Quality

CBR Maximal Bit Rate

**GOP Structure and Length**

In this section you can configure the composition of the MPEG-4 video stream (GOP structure). By using I-Frame only will increase video quality dramatically but also the bandwidth.

Group of Picture(GOP)  (1 indicates to generate I-VOP only and disable motion detection)  
Size

**Alarm Settings**

In this section you can configure pre-alarm and post-alarm settings.

Pre-alarm recording time  seconds

Post-alarm recording time  seconds with hard disk installed (1~30)

Split interval  minutes

Record audio

Overlaid with camera name

Overlaid with date stamps

Overlaid with time stamps

Overlaid with digital input description name  Input 1  Input 2

**Apply All Settings**

In this section you can apply the settings to all cameras

Apply the settings to all cameras

Figure 4-3

**[Name]**

Rename the camera. The camera name will appear on the Live View. To display the camera name, see 3.2.9 *Camera Name Display*.

**[Connection Template]**

Select the type of your network connection. Unless you select **Customized**, this option will automatically bring up the recommended video resolution, frame rate, bandwidth and GOP size.

Due to the bandwidth limitation for mobile phone connections, only the video resolutions 360 x 240 (360 x 288) and 176 x 122 (176 x 144) are supported. The higher resolution you select, the higher frame rate or better video quality you will get. But note that your mobile phone must support the video resolution you wish to select.

Connection templates for mobile phone connections:

<b>GView V2 Supported</b>	
<b>Resolution</b>	<b>Frame Rate</b>
NTSC 360 x 240	15
PAL 360 x 288	12.5
<b>3GPPv7, Msview V2, Msview V3, Ssview V3 and GView V2 Supported</b>	
<b>Resolution</b>	<b>Frame Rate</b>
NTSC 360 x 240	7.5
PAL 360 x 288	8
<b>3GPPv6, Msview V2, Msview V3, Ssview V3 and GView V2 Supported</b>	
<b>Resolution</b>	<b>Frame Rate</b>
NTSC 176 x 112	5
PAL 176 x 144	5

### [Video Signal Type]

- **Auto detect signal type on booting:** Automatically detects the type of video input is NTSC or PAL.

The supported codecs vary from model to model.

Model	Codec
GV-VS02	MPEG4
GV-VS02A	MPEG4
GV-VS04A	MPEG4
GV-VS12	MPEG4 , MJPEG, H.264
<b>Note:</b> The Main Streaming Type drop-down list is only available for GV-VS12.	

There are 4 options for selecting image resolutions.

NTSC	PAL
720 x 480	720 x 576
720 x 480 De-interlaced	720 x 576 De-interlaced
360 x 240	360 x 288
176 x112	176 x 144

Several frame rates are available.

Format	Frame Rate
NTSC	1, 2, 3, 5, 7.5, 10, 15, 30
PAL	1, 2.5, 5, 8, 12.5, 25

### [Bandwidth Management]

When using MPEG-4 or H.264, it is possible to control the bitrate, which in turn allows the amount of bandwidth usage to be controlled.

- **VBR (Variable Bitrate):** The quality of the video stream is kept as constant as possible at the cost of a varying bitrate. The bandwidth is much more efficiently used than a comparable CBR.

Set the image quality to one of the 3 standards: **Fair**, **Good**, and **Excellent**.

- **CBR (Constant Bitrate):** CBR is used to achieve a specific bitrate by varying the quality of the stream. The bitrates available for selection depend on the image resolution.

Model	Bitrates for selection
GV-VS02	3072 kbps, 2048 kbps, 1536 kbps, 1024 kbps, 768 kbps, 512 kbps, 384 kbps, 256 kbps (3GPPV7), 128 kbps (3GPPV7) , 64 kbps (3GPPV6) and 52 kbps (3GPPV6)
GV-VS02A	
GV-VS04A	
GV-VS12	2048 kbps, 1536 kbps, 1024 kbps, 768 kbps, 512 kbps, 384 kbps, 256 kbps (3GPPV7), 128 kbps (3GPPV7) , 64 kbps (3GPPV6) and 52 kbps (3GPPV6)

### [GOP Structure and Length]

Set the maximum number of frames in a GOP structure (the GOP size limit). This function is only available when you select Customized in the Connection Template section.

### [Alarm Settings]

The alarm settings allow you to capture images before and/or after the motion or I/O event happens.

- **Pre-alarm recording time:** Activates video recording before an event occurs. Set the recording time to 1 or 2 seconds.
- **Post-alarm recording time:** Activates video recording onto the attached USB mass storage device after an event occurs. Set the recording time from 1 to 30 seconds.
- **Split Interval:** Sets the time length between each event file from 1 to 5 minutes.
- **Record Audio:** Activates audio recording when an event occurs.
- **Overlaid with camera name:** Includes camera names on live and recorded videos.
- **Overlaid with date stamps:** Includes date stamps on live and recorded videos.
- **Overlaid with time stamps:** Includes time stamps on live and recorded videos.
- **Overlaid with digital input description name:** Includes the names of selected inputs on live and recorded videos.

**[Watermark]** Enable this option to watermark all recordings. The watermark allows you to verify whether the video has been tampered while it was recorded and saved. See 6.5 *Verifying Watermark*.

### [Apply All Settings]

- **Apply the settings to all cameras:** Applies the same settings to the other camera.

### 4.1.3 Motion Detection

Motion detection is used to generate an alarm whenever movement occurs in the video image. You can configure up to 8 areas with different sensitivity values for motion detection.

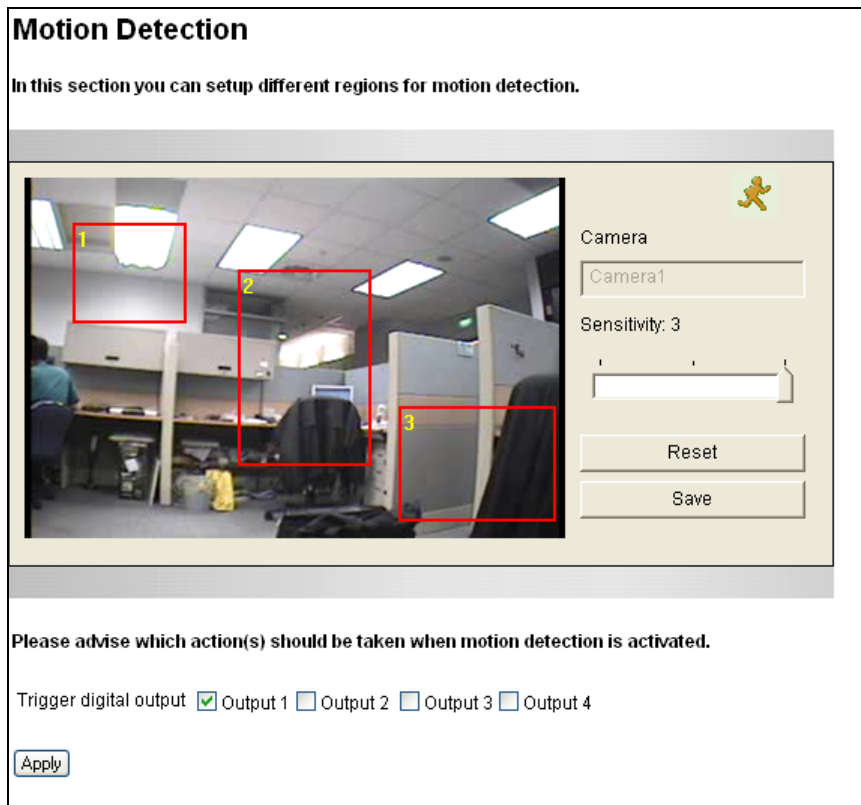

Figure 4-4

1. The default sensitivity value is 2 for the whole area. To define a different sensitivity value, click **Reset**.
2. Select the desired sensitivity by moving the slider. There are three values. The higher the value, the more sensitive the camera is to motion.
3. Drag an area on the image. Click **Add** when you are prompted to confirm the setting.
4. To create several areas with different sensitivity values, repeat Steps 2 and 3.
5. Click **Save** to save the above settings.
6. To trigger the alarm outputs when motion is detected, select the outputs (Output 1 to Output 4) and click the **Apply** button. To activate the output settings, you must also start **Camera** monitoring manually or by schedule. For related settings, see 4.4 *Monitoring*.

---

**Note:** For GV-VS12 users, this function does not work when MJPEG is selected as the codec in the Video Signal Type field (Figure 4-1). For details, see 4.1.2 *Video Settings*.

---

### 4.1.4 Privacy Mask

The Privacy Mask can block out sensitive areas from view, covering the areas with dark boxes in both live view and recorded clips. This feature is ideal for locations with displays, keyboard sequences (e.g. passwords), and for anywhere else you don't want sensitive information visible.

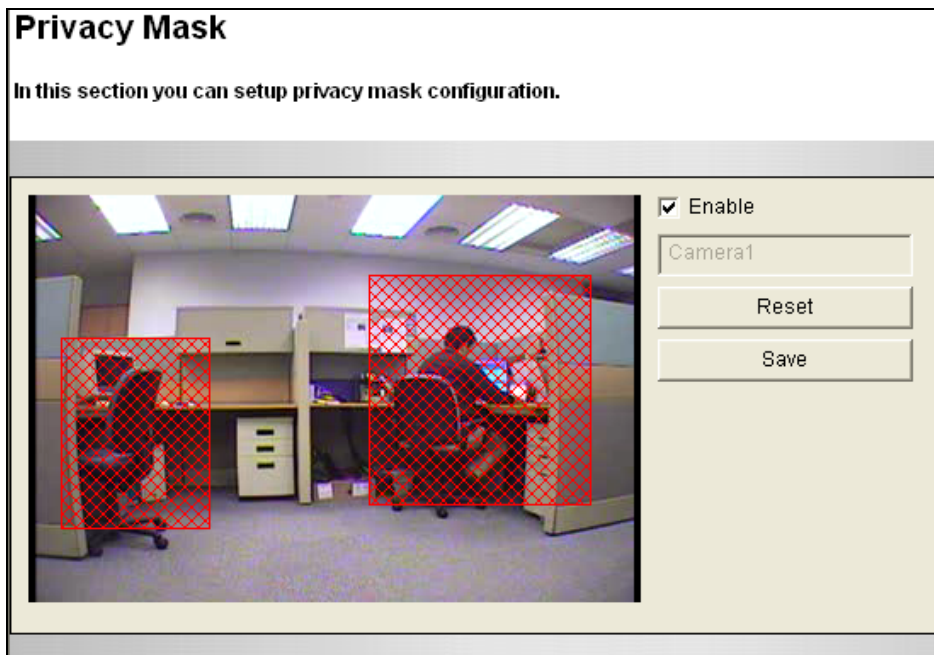

Figure 4-5

1. Select the **Enable** option.
2. Drag the area(s) where you want to block out on the image. Click **Add** when you are prompted to confirm the setting.
3. Click the **Save** button to save all the settings.

## 4.1.5 Text Overlay

Note this option is only available on **GV-VS02A** (Firmware Version 1.01 or later), **GV-VS04A** and **GV-VS12** (Firmware Version 1.02 or later).

The Text Overlay function allows you to type any text in any place on the camera view. Up to 16 text messages can be created. The overlaid text will also be saved in the recorded images.

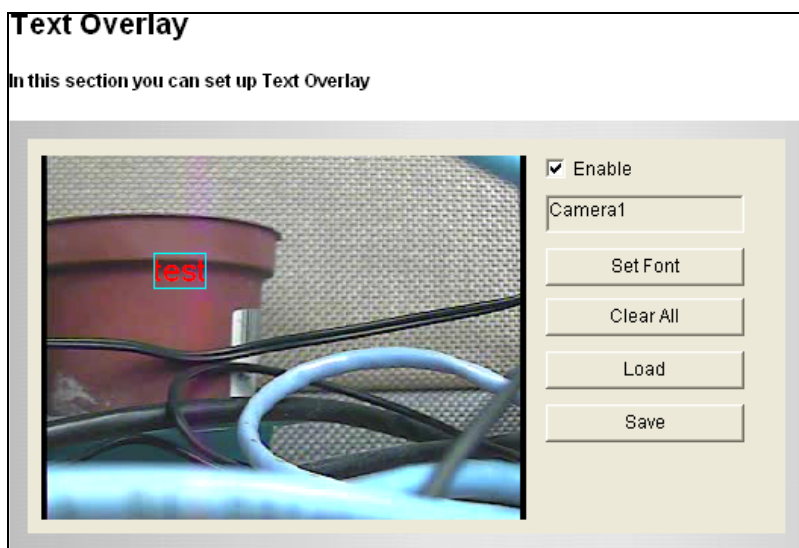

Figure 4-6

1. Select the **Enable** option.
2. Click any place on the image. This dialog box appears.

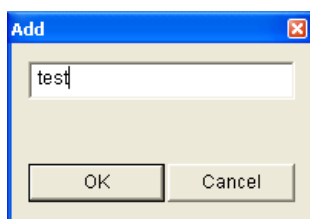

Figure 4-7

3. Type the desired text, and click **OK**. The text is overlaid on the image.
4. Click on the text and drag it to any place on the image.
5. Click **Set Font** to modify the font style of the text.
6. Click **Save** to apply the settings, or click **Load** (Undo) to revert to a previous setting.



### 4.1.6 Tampering Alarm

Note this option is only available on **GV-VS02A** (Firmware Version 1.01 or later), **GV-VS04A** and **GV-VS12** (Firmware Version 1.02 or later).

The Tampering Alarm is used to detect when a camera is being physically tampered. An alarm can be generated when the camera is moved, covered up, or out of focus. The alarm approaches include the triggered output device, e-mail alert and system buzzer. To have the tampering alarm, first set up these alarm approaches properly:

- To trigger the output device when a tamper event occurs, enable the output setting and select **Tampering Alarm** for the related camera. See *Output Setting* in 4.2.2 *Input/Output Settings*.
- To trigger the e-mail alert when a tamper event occurs, enable the e-mail setting and select **Tampering Alarm** for the related camera. See 4.3.1 *E-Mail*.
- To trigger the system buzzer when a tamper event occurs, enable the buzzer setting. See 4.2.4 *Buzzer*.

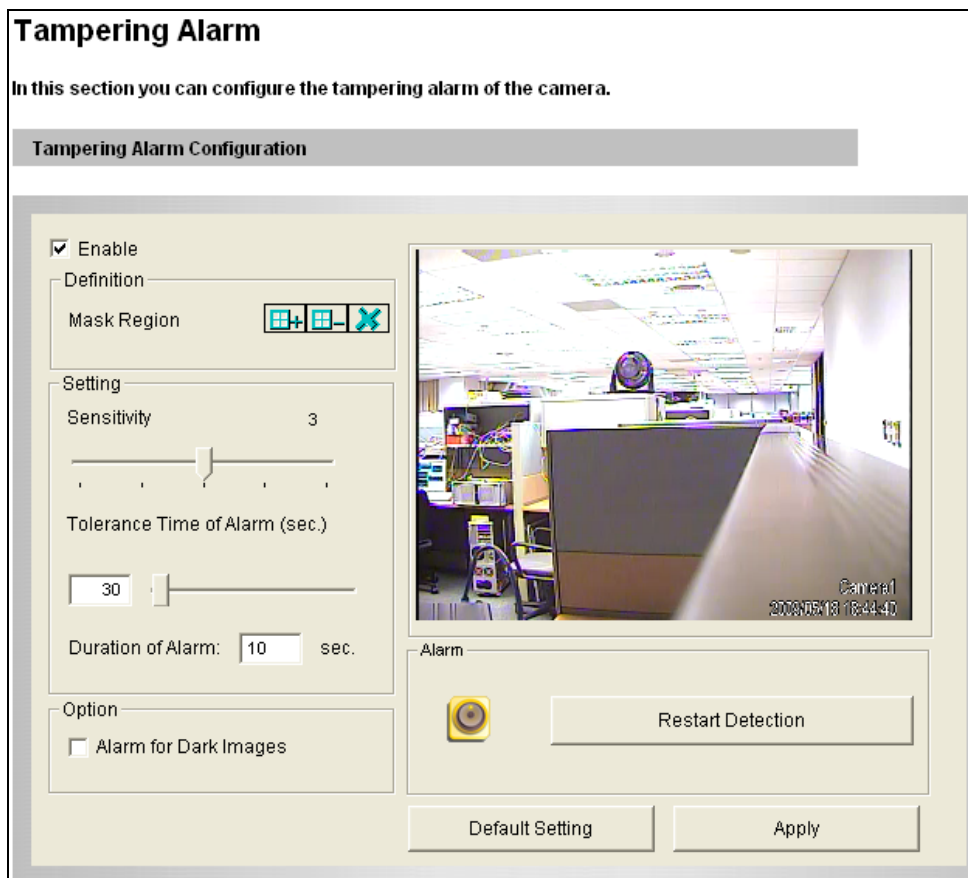



Figure 4-8

To configure the tampering alarm:

1. Select the **Enable** option.
2. If you want GV-Video Server to ignore any movement or scene change in certain areas, click the  button to drag areas on the camera view.
3. Select the desired detection sensitivity by moving the slider. The higher the value, the more sensitive the camera is to scene changes.
4. In the **Tolerance Time of Alarm** field, specify the time length allowed for scene changes before an alarm is generated.
5. In the **Duration of Alarm** field, specify the duration of the alarm after which the triggered output device or system buzzer will be turned off.
6. To trigger an alarm when the scene turns dark, e.g. the lens of camera has been covered, select **Alarm for Dark Images**.
7. Click **Apply** to save all the settings.
8. Start monitoring to enable the function. To have buzzer alarm, it is required to start the **Camera** monitoring. To have output alarm, it is required to start **Input** monitoring. For these two types of monitoring, see *4.4 Monitoring*.

When the camera has been tampered, the output device and system buzzer can be activated. To turn off the output device and system buzzer immediately, return to this setting page, and click **Restart Detection**.

---

**Note:** GV-VS12 does not support the system buzzer.

---

### 4.1.7 Visual Automation

This intuitive feature helps you automate any electronic device by triggering the connected output device. When you click on the image of the electronic device, you can simply change its current state, e.g. light ON.

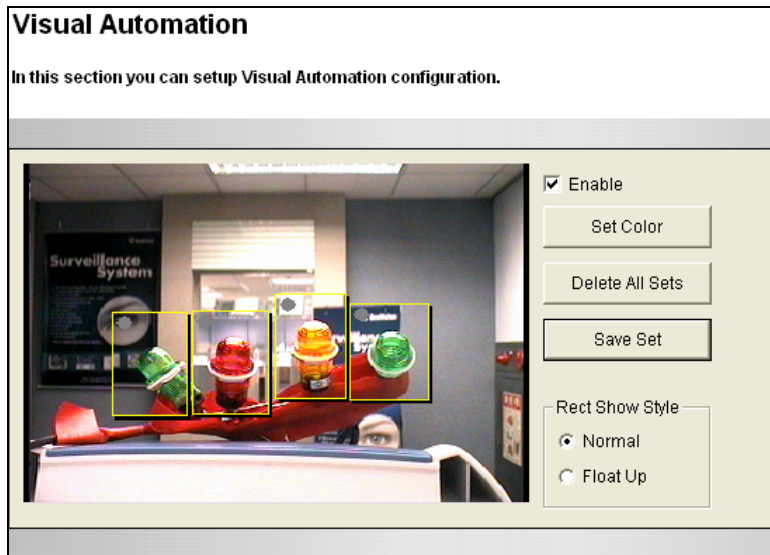

Figure 4-9

1. Select the **Enable** option.
2. Drag an area on the image of the electronic device. This dialog box appears.

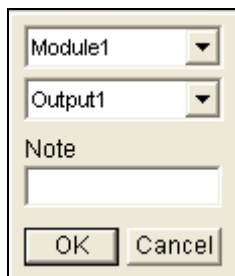

Figure 4-10

3. Assign the connected module and output device. In the Note field, type a note to help you manage the device. Click **OK** to save the settings.
4. To change the frame color of the set area, click the **Set Color** button.
5. To emboss the set area, select **Float Up**; or keep it flat by selecting **Normal**.
6. Click the **Save Set** button to apply the settings.

To perform the function, see [3.2.14 Visual Automation](#).

## 4.1.8 Video Channel Source Settings

Note this option is only available for **GV-VS02A** (Firmware Version 1.01 or later) and **GV-VS04A**.

The function allows you to assign the video input to the desired video channel for display.

### Video Channel Source Settings

In this section you can configure video source input. After click enable checkbox, you can assign each video channel with specific video input source. Otherwise, each video channel is based on hardwired connection.

#### Video Channel Source Settings

Enable video source swapping:

Video channel 1	Video input source 1
Video channel 2	Video input source 2
Video channel 3	Video input source 3
Video channel 4	Video input source 4

Apply

Figure 4-11

## 4.2 Digital I/O & PTZ

For auxiliary device control, you can find one I/O / PTZ port along with one RS-232 terminal block for GPS control on the rear panel of **GV-VS12** (see Figure 1-9). Differently, on the rear panels of **GV-VS02**, **GV-VS02A** and **GV-VS04A**, all the functions for auxiliary device control are included in a 16-pin terminal block. For details, see *Chapter 9 Auxiliary Device Connectors*.

The connectors for all terminal blocks on all models and the I/O / PTZ port on the GV-VS12 can be divided into four categories based on the interface being used:

1. Digital Input / Relay Output
2. RS-485 interface for PTZ control
3. Wiegand interface for access control  
(available on GV-VS02, GV-VS02A and GV-VS04A)
4. GPS interface for vehicle tracking:
  - UART: available on GV-VS02 (Hardware Version 2.0), GV-VS02A and GV-VS04A
  - RS-232: available on GV-VS12

### 4.2.1 PTZ Settings

Through the RS-485 interface on the I/O terminal block, you can connect 2 to 4 PTZ cameras depended on models. Before adding a PTZ camera to the GV-Video Server, you must install the PTZ components from the Software DVD by selecting **Install PTZ** on the installation menu. Then open this PTZ Settings page to configure the baud rate, speed and address. For these settings, please consult your PTZ documentation.

Figure 4-12

---

**Note:** Currently the GV-Video Server doesn't support the PTZ camera with RS-232 interface.

---

## 4.2.2 Input/Output Settings

### Input Setting

The number of input devices the GV-Video Server can connect to vary from model to model. GV-VS02, GV-VS02A and GV-VS04A connect up to 4 input devices; GV-VS12 connects up to 2 input devices.

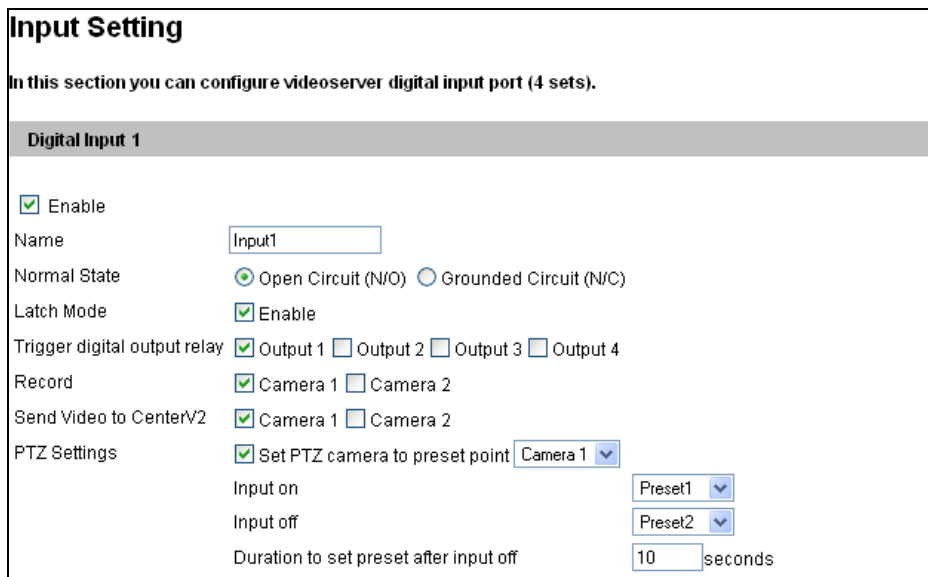

**Input Setting**

In this section you can configure videosever digital input port (4 sets).

**Digital Input 1**

Enable

Name

Normal State  Open Circuit (N/O)  Grounded Circuit (N/C)

Latch Mode  Enable

Trigger digital output relay  Output 1  Output 2  Output 3  Output 4

Record  Camera 1  Camera 2

Send Video to Center/V2  Camera 1  Camera 2

PTZ Settings  Set PTZ camera to preset point

Input on

Input off

Duration to set preset after input off  seconds

Figure 4-13

- **Normal State:** Set up the input state to trigger actions by selecting Open Circuit (N/O) or Grounded Circuit (N/C).
- **Latch Mode:** Enable the mode to have a momentary output alarm.
- **Trigger Digital Output Relay:** Select the output(s) to be triggered once the input is activated.
- **Record:** Select the camera(s) to start recording once the input is activated.
- **Send Video to Center V2:** Select the camera(s) to send their images to Center V2 when the input is triggered.

You can direct a PTZ camera to a preset point upon input trigger:

- **Set PTZ camera to preset point:** Enable the preset function and select the camera that represents the PTZ camera.
- **Input on:** Direct the PTZ camera to a preset point when the input is triggered.
- **Input off:** Direct the PTZ camera to another preset point when the triggered input is off.

- **Duration to set preset after input off x seconds:** Specify the amount of time the PTZ camera stays in “Input on” preset point before moving to “Input off” preset point.

---

**Note:** The input settings only function after you start **Input** monitoring manually or by schedule. To configure the input monitoring, see [4.4 Monitoring](#).

---

For related PTZ settings, see [4.2.1 PTZ Settings](#).

## Output Setting

The number of output devices the GV-Video Server can connect to vary from model to model. GV-VS02, GV-VS02A and GV-VS04A connect up to 4 output devices; GV-VS12 connects up to 2 output devices.

**Output Setting**

In this section you can configure videosever digital output port(4 sets).

**Digital Output 1 - Normal State**

Enable

Name

General Mode  Open Circuit (N/O)  Grounded Circuit (N/C)

Toggle Mode  Open Circuit (N/O)  Grounded Circuit (N/C)

Pulse Mode  Open Circuit (N/O)  Grounded Circuit (N/C)

Trigger Pulse Mode for  seconds(1~60)

**Digital Output 1 - Alarm Settings**

Video Lost  Select all  Camera 1  Camera 2

Tampering Alarm  Select all  Camera 1  Camera 2

Rec Error

HD Full

Figure 4-14

Select **Enable** to enable the output device. Choose the output signal that mostly suits the device you are using: N/O (Open Circuit), N/C (Grounded Circuit), N/O Toggle, N/C Toggle, N/O Pulse or N/C Pulse. For **Toggle** output type, the output will keep going on once it is triggered until the next trigger. For **Pulse** output type, the output is triggered for the amount of time you specify in the Trigger Pulse Mode for x Seconds field.

- **Alarm Settings:**

Note this option is only available for **GV-VS02A**, **GV-VS04A** and **GV-VS12**.

You can choose to automatically activate the configured output device for alarm under these conditions: video lost, tampering alarm, disk write error (Rec Error) and hard disk full (HD Full).

### 4.2.3 GPS/Wiegand

You can select either GPS or Wiegand function for use. The two functions cannot be enabled at the same time.

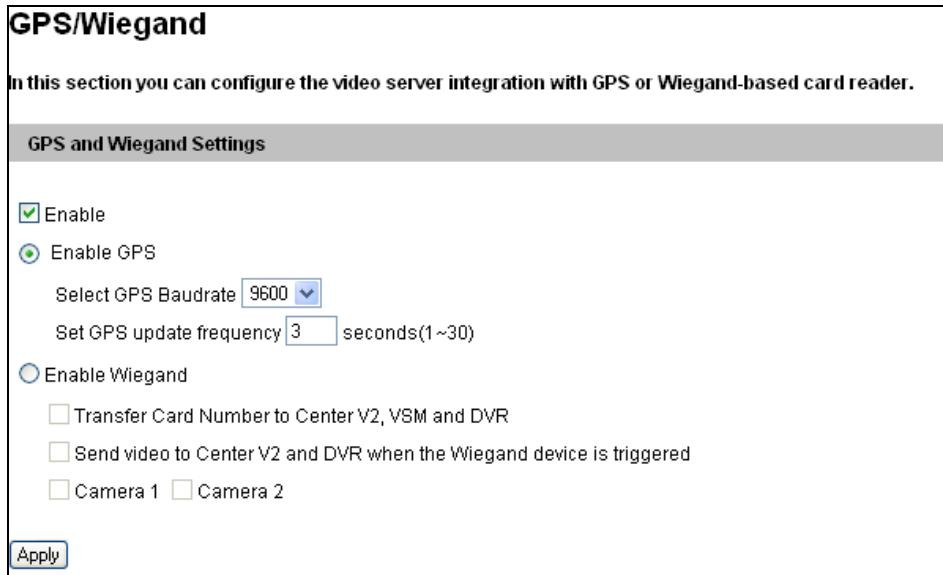

Figure 4-15

#### GPS Function

Note this function is only available for **GV-VS02** (Hardware Version 2.0), **GV-VS02A**, **GV-VS04A** and **GV-VS12**.

To enable the GPS function, a GV-GPS module or any GPS module supporting UART or RS-232 interface is required to connect to the GV-Video Server first. See *Chapter 9 Auxiliary Device Connectors*.

- **Select GPS Baudrate:** Two baud rate options are available: 4800 and 9600. By default the value is 9600.
- **Set GPS Update Frequency:** Set the update frequency in seconds for GPS data.

After the GPS function is activated, you can view the location of the GV-Video Server on Google Maps. See 6.3 *GPS Tracking*. If the monitoring is also activated, the GPS tracking routes will be recorded along with videos. This makes it possible to play back tracking routes and videos together on GV-System. See 5.2.3 *Playback of GPS Tracking Routes*.



## Wiegand Function

Note this function is only available for **GV-VS02**, **GV-VS02A** and **GV-VS04A**.

The GV-Video Server can work in conjunction with the Wiegand-interface card reader to send video and cardholder data to the central monitoring stations Center V2 and VSM, as well as GV-System (DVR). Moreover, the Wiegand port on the GV-Video Server can be used as an input to activate recording once the card reader is triggered or a valid card is present to the card reader.

The output format of Wiegand supported by the GV-Video Server is HID standard 26 bits and 37 bits.

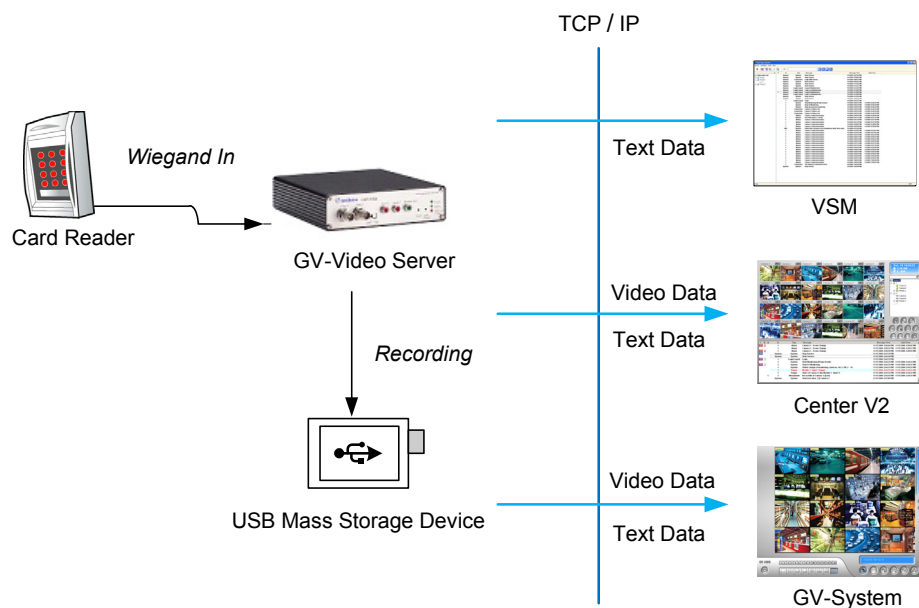

Figure 4-16

- **Transfer Card Number to Center V2, VMS and DVR:** Sends the cardholder data to Center V2, VSM and GV-System once the card reader is triggered.
- **Send video to Center V2 and DVR when the Wiegand device is triggered:** The selected camera(s) will start recording into GV-Video Server and the related video will also be sent to Center V2 and GV-System once the card reader is triggered.

---

**Note:** To receive cardholder data from the GV-Video Server, the GV-System must be version 8.2 or later.

---

For the related settings, see 4.3.3 Center V2, 4.3.4 VSM and 7.2 Receiving Cardholder Data from Video Server.

## 4.2.4 Buzzer

Note this function is only available for **GV-VS02A** (Firmware Version 1.01 or later) and **GV-VS04A**.

The system buzzer can be activated automatically under these conditions: video lost, input device triggered, motion detected, disk full, disk write error and tampering alarm. You can set the duration of buzzing sounds to be **5 Seconds**, **10 Seconds**, **20 Seconds** or **30 Seconds**. To turn on the buzzer, select **On**; to turn off the buzzer, select **Off**.

It is required to start monitoring for the buzzer to work. To start monitoring, see [4.4 Monitoring](#).

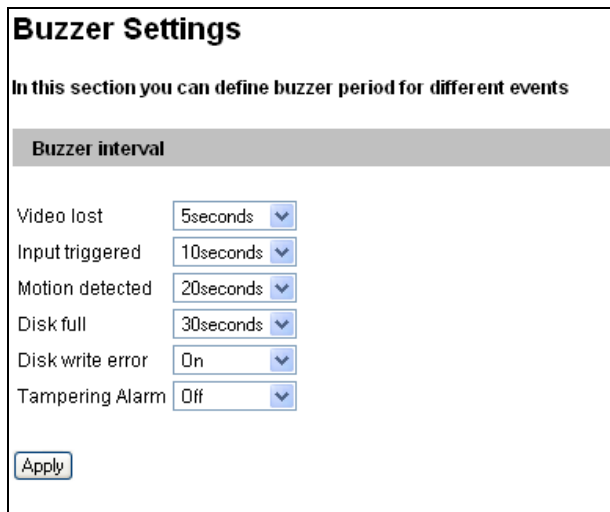

Buzzer Settings	
In this section you can define buzzer period for different events	
Buzzer interval	
Video lost	5seconds
Input triggered	10seconds
Motion detected	20seconds
Disk full	30seconds
Disk write error	On
Tampering Alarm	Off
<input type="button" value="Apply"/>	

Figure 4-17

## 4.3 Events & Alerts

For the events of motion detection or I/O trigger, the Administrator can set up the two trigger actions:

1. Send a captured still image by e-mail or FTP.
2. Notify Center Monitoring Station, Center V2, VSM or GV-GIS, by video or text alerts.

To have above trigger actions, you must also set the following features:

- Motion Detection (See 4.1.3 *Motion Detection*)---optional
- Input Setting (See 4.2.2 *Input/Output Settings*)
- For e-mail and FTP alerts, it is required to start monitoring (See 4.4 *Monitoring*).

---

**Note:** The Motion Detection function is an optional setting since it is activated by default.

---

### 4.3.1 E-mail

After a trigger event, the GV-Video Server can send the e-mail to a remote user containing a captured still image.

Figure 4-18

**[Enable]** Select to enable the e-mail function.

- **Sever URL/IP Address:** Type the SMTP Server's URL address or IP address.
- **Server Port:** Type the SMTP Server's port number. Or keep the default value 25.
- **From email address:** Type the sender's e-mail address.

- **Send to:** Type the e-mail address(s) you want to send alerts to.
- **Alerts Interval Time:** Specify the interval between e-mail alerts. The interval can be between 0 and 60 minutes. The option is useful for the frequent event occurrence, by which any event triggers during the interval period will be ignored.

**[Need authentication to login]** If the SMTP Server needs authentication, select this option and type the valid username and password.

**[This server requires a secure connection]** If the SMTP Servers needs a secure connection (SSL), select this option.

**[Alarm Settings]** You can choose to automatically send an e-mail for alarm notification under these conditions: video lost, tampering alarm, disk write error (Rec Error) and hard disk full (HD full).

---

**Note:**

1. The **This server requires a secure connection** option is only available on GV-VS02A (Firmware Version 1.01 or later), GV-VS04A and GV-VS12 (Firmware Version 1.02 or later).
  2. The **Alarm Settings** option is only available on GV-VS02A, GV-VS04A and GV-VS12.
- 

For the related settings to send e-mail alerts, see *4.1.3 Motion Detection*, *4.2.2 Input/Output Settings* and *4.4 Monitoring*.

### 4.3.2 FTP

You can also send the captured still image to a remote FTP server for alerts.

**FTP Client and Server Setting**

In this section you can configure a ftp server (File Transfer Protocol) to handle events, videos, and error messages.

**Upload to a FTP server**

Enable

Server URL/IP Address

Server Port

User Name

Password

Remote Directory

Alerts Interval time in minute (0 to 60)

**FTP - Alarm Settings**

Motion Detection     Select all     Camera 1     Camera 2

Continuously send images upon trigger events(Motion)

Digital Input     Select all     Input1     Input2     Input3     Input4

Continuously send images upon trigger events(Input)

**Act as FTP server**

In this section you can enable/disable videosever internal ftp server for file transfer.

Enable ftp access to the videosever

Use alternative Port

Figure 4-19

#### [Upload to a FTP Server]

- **Enable:** Select to enable the FTP function.
- **Server URL/IP Address:** Type the URL address or IP address of the FTP Server.
- **Port Number:** Type the port number of the FTP Server. Or keep the default value 21.
- **User Name:** Type a valid user name to log into the FTP Server.
- **Password:** Type a valid password to log into the FTP Server.
- **Remote Directory:** Type the name of the storage folder on the FTP Server.
- **Alerts Interval time in minute:** Specify the interval between FTP alerts. The interval can be between 0 and 60 minutes. The option is useful for the frequent event occurrence by which any event triggers during the interval period will be ignored.

### [Alarm Settings]

- **Motion Detection:** Once the motion is detected on the selected camera, a still image will be sent to the FTP Server.
  - ⊙ **Continuously send images upon trigger events (motion):** A sequence of snapshot images are uploaded to the FTP Server when motion is detected on the selected camera.
- **Digital Input:** Once the selected input is triggered, a still image from **Camera 1** will be sent to the FTP Server.
  - ⊙ **Continuously send images upon trigger events (input):** A sequence of snapshot images from **Camera 1** are uploaded to the FTP Server when the selected input is triggered.

---

**Note:** By default, only **Camera 1** images will be sent to the FTP Server for the Digital Input trigger application.

---

- **Snapshot Resolution:** (This option is only available for GV-VS02A Firmware V1.0.) Select D1 or CIF to be the resolution of snapshot images.

### [Act as FTP Server]

- **Enable FTP access to the video server:** The GV-Video Server acts as a FTP server, enabling users to download AVI files.
- **Use alternative port:** The default port is set to 21.

To access the internal FTP server through a web browser, enter the IP address or the domain name of the GV-Video Server in your browser like this:

ftp://192.168.0.10

When you are prompted for Username and Password, enter the default value **videoserver** in both fields. Then you should find the AVI files recorded after trigger events.

To change login information of the internal FTP server, see *4.8.5 User Account*. For the related settings to send FTP alerts, see *4.1.3 Motion Detection*, *4.2.2 Input/Output Settings* and *4.4 Monitoring*.

### 4.3.3 Center V2

After a motion or an I/O triggered event, the central monitoring station Center V2 can get notified by live videos and text alerts. For the live monitoring through Center V2, you must already have a subscriber account on Center V2.

**Note:** To receive video alerts on input triggers, the Center V2 must use version 8.2 or later. Otherwise, the Center V2 will only have text alerts on input triggers.

#### Center V2

In this section you can configure the connection to Center V2 and tasks to perform.

**Center V2 server**

Activate Link

Host name or IP Address:

Port number:

User Name:

Password:

Cease motion detection messages from  Select all  Camera 1  Camera 2

Cease input trigger message from  Select all  Input 1  Input 2  Input 3  Input 4

Enable schedule mode

**Select schedule time**

Span 1  :  ~  :  Next Day

Span 2  :  ~  :  Next Day

Span 3  :  ~  :  Next Day

Weekend  Saturday and Sunday  Only Sunday

Special Day (MM/DD)

01.  02.  03.  04.

05.  06.  07.  08.

09.  10.  11.  12.

**Connection Status**

Status: Connected. Connected Time: Wed May 30 04:31:30 2007

Figure 4-20

To enable the Center V2 connection:

1. **Activate Link:** Enable the monitoring through Center V2.
2. **Host Name or IP Address:** Type the host name or IP address of Center V2.
3. **Port Number:** Match the port to **Port 2** on Center V2. Or keep the default value 5551. For details, see *8.1 Center V2*.
4. **User Name:** Type a valid user name to log into Center V2.
5. **Password:** Type a valid password to log into Center V2.
6. Click **Apply**. The Connection Status should display “Connected” and connected time.

These options you can also find on this Center V2 setting page:

- **Cease motion detection messages from:** Stops notifying Center V2 of motion detection from the selected camera.
- **Cease input trigger messages from:** Stops notifying Center V2 of input trigger from the selected input.
- **Enable schedule mode:** Starts the monitoring through Center V2 based on the schedule you set in the **Select Schedule Time** section. Refer to *4.5 Recording Schedule* for the same settings.

For related settings to activate the monitoring through Center V2, see *4.1.2 Motion Detection*, *4.2.2 Input/Output Setting*, and *8.1 Center V2*.



### 4.3.4 VSM

After a motion or an I/O triggered event, the central monitoring station VSM can get notified by text alerts. For the live monitoring through VSM, you must already have a subscriber account on VSM.

#### Vital Sign Monitor Server Setting

In this section you can configure the connection to VSM Server and tasks to perform.

**Vital Sign Monitor Server**

Activate Link

Host name or IP Address:

Port number:

User Name:

Password:

Cease motion detection messages from  Select all  Camera 1  Camera 2

Cease input trigger message from  Select all  Input 1  Input 2  Input 3  Input 4

Enable schedule mode

**Select schedule time**

Span 1   ~   Next Day

Span 2   ~   Next Day

Span 3   ~   Next Day

Weekend  Saturday and Sunday  Only Sunday

Special Day (MM/DD)

01.  02.  03.  04.

05.  06.  07.  08.

09.  10.  11.  12.

**Connection Status**

Status: Connected. Connected Time: Sun Jan 16 07:33:59 2000

Figure 4-21

To enable the VSM connection:

1. **Activate Link:** Enable the monitoring through VSM.
2. **Host Name or IP Address:** Type the host name or IP address of VSM.

3. **Port Number:** Match the port to **Port 2** on VSM. Or keep the default value 5609. For details, see *8.1 Center V2*.
4. **User Name:** Type a valid user name to log into VSM.
5. **Password:** Type a valid password to log into VSM.
6. Click **Apply**. The Connection Status should display “Connected” and connected time.

These options you can also find on this VSM setting page:

- **Cease motion detection messages from:** Stops notifying VSM of motion detection from the selected camera.
- **Cease input trigger messages from:** Stops notifying VSM of input trigger from the selected input.
- **Enable schedule mode:** Starts the monitoring through VSM based on the schedule you set in the **Select Schedule Time** section. Refer to *4.5 Recording Schedule* for the same settings.

For related settings to activate the monitoring through VSM, see *4.1.3 Motion Detection*, *4.2.2 Input/Output Settings*, and *8.2 VSM*.

### 4.3.5 GV-GIS

Note the GV-GIS with two connections is only available on **GV-VS02A** (Firmware Version 1.01 or later), **GV-VS04A** and **GV-VS12** (Firmware Version 1.02 or later).

Through the Internet connection, the GV-Video Server with enabled-GPS function can send GPS data and live video to the GV-GIS (Geographic Information System) for the services of vehicle tracking, location verification and live monitoring. The GV-Video Server can connect up to 2 GV-GIS stations simultaneously.

Before you configure the GV-GIS connection on this setting page, the following conditions must be met:

- A subscriber account created on the GV-GIS
- UMTS connection activated on the GV-Video Server (See 4.7.4 UMTS)
- GPS function activated on the GV-Video Server (See 4.2.3 GPS/Wiegand)

Connection 1
Connection 2

## GV-GIS

In this section you can configure the connection to GV-GIS and tasks to perform.

GV-GIS Server

Activate Link

Host name or IP Address:

Port number:

User Name:

Password:

Enable schedule mode

Select schedule time

Span 1  :  :  ~  :  Next Day

Span 2  :  :  ~  :  Next Day

Span 3  :  :  ~  :  Next Day

Weekend  Saturday and Sunday  Only Sunday

Special Day (MM/DD)

01.  02.  03.  04.

05.  06.  07.  08.

09.  10.  11.  12.

Figure 4-22

To enable the GV-GIS connection:

1. **Activate Link:** Enable the monitoring through GV-GIS.
2. **Host Name or IP Address:** Type the host name or IP address of GV-GIS.
3. **Port Number:** Match the communication port on GV-GIS. Or keep the default value 3356.
4. **User Name:** Type a valid user name to log into GV-GIS.
5. **Password:** Type a valid password to log into GV-GIS.
6. **Enable Schedule Mode:** Enable the monitoring through GV-GIS based on the schedule you set in the **Select Schedule Time** section. Refer to *4.5 Recording Schedule* for the same settings.
7. Click **Apply**. The Connection Status should display “Connected” and connected time.
8. To establish the connection to the second GV-GIS station, click the **Connection 2** tab and repeat Steps 1 to 7 for settings.

For related settings to activate the monitoring through GV-GIS, see *4.1.3 Motion Detection*, and *4.2.2 Input/Output Setting*.

For details on GV-GIS, see *GV-GIS User's Manual*.

### 4.3.6 Backup Center

Note the function is only available on **GV-VS02A** (Firmware Version 1.01 or later), **GV-VS04A** and **GV-VS12** (Firmware Version 1.02 or later).

The connection to the Backup Center allows you to back up another copy of recordings and system log to the Backup Center while the GV-Video Server is saving these data to the attached hard disk.

#### Backup Center

In this section you can configure the connection to Backup Center and tasks to perform.

---

##### Backup Center

Activate Link

Host name or IP Address:

Port number:

User Name:

Password:

Set update frequency  minutes

Automatic Failover Support

Host name or IP Address:

Port number:

User Name:

Password:

Enable schedule mode

---

##### Select schedule time

Span 1  :  ~  :  Next Day

Span 2  :  ~  :  Next Day

Span 3  :  ~  :  Next Day

Weekend  Saturday and Sunday  Only Sunday

Special Day (MM/DD)

01.  02.  03.  04.

05.  06.  07.  08.

09.  10.  11.  12.

Figure 4-23

To enable the Backup Center connection:

1. **Activate Link:** Enable the connection to the Backup Center.
2. **Host Name or IP Address:** Type the host name or IP address of the Backup Center.

3. **Port Number:** Match the communication port on the Backup Center. Or keep the default value 30000.
4. **User Name:** Type a valid user name to log into the Backup Center.
5. **Password:** Type a valid password to log into the Backup Center.
6. **Enable Schedule Mode:** Enable the Backup Center connection on the schedule you set in the **Select Schedule Time** section. Refer to *4.5 Recording Schedule* for the same settings.
7. Click **Apply**. The Connection Status should display “Connected” and connected time.

If the Backup Center has a failover server providing the uninterrupted backup services in case of the Backup Center failure, you can configure the connection to the failover server.

1. **Set Update Frequency:** Once the GV-Video Server is disconnected from the Backup Center for the specified time, the GV-Video Server will be directed to the failover server.
2. **Automatic Failover Support:** Enable the automatic connection to the failover server once the connection between GV-Video Server and Backup Center is interrupted for the specified time.
3. **Host Name or IP Address:** Type the host name or IP address of the failover center.
4. **Port Number:** Match the communication port on the failover server. Or keep the default value 30000.
5. **User Name:** Type a valid user name to log into the failover server.
6. **Password:** Type a valid password to log into the failover server.
7. Click **Apply**.

### 4.3.7 Video Gateway

Note the function is only available on **GV-VS02A** (Firmware Version 1.01 or later), **GV-VS04A** and **GV-VS12** (Firmware Version 1.02 or later).

To send the video images to the Video Gateway, follow the steps below.

**Video Gateway**

In this section you can configure the connection to Video Gateway and tasks to perform

**Video Gateway server**

Activate Link

Host name or IP Address:

Port number:

User Name:

Password:

Cease motion detection messages from  Select all  Camera 1  Camera 2  Camera 3  Camera 4

Enable schedule mode

**Select schedule time**

Span 1  :  ~  :

Span 2  :  ~  :

Span 3  :  ~  :

Weekend  Saturday and Sunday  Only Sunday

Special Day (MM/DD)

01.  02.  03.  04.

05.  06.  07.  08.

09.  10.  11.  12.

Figure 4-24

1. **Activate Link:** Enable the connection to the Video Gateway.
2. **Host Name or IP Address:** Type the host name or IP address of the Video Gateway.
3. **Port Number:** Match the communication port on the Video Gateway. Or keep the default value 50000.
4. **User Name:** Type a valid user name to log into the Video Gateway.
5. **Password:** Type a valid password to log into the Video Gateway.
6. **Cease motion detection messages from:** Stop sending the videos of motion detection from the selected camera.
7. **Enable schedule mode:** Enable the Video Gateway connection on the schedule you set in the **Select Schedule Time** section. Refer to *4.5 Recording Schedule* for the same settings.
8. Click **Apply**. The Connection Status should display “Connected” and connected time.

### 4.3.8 ViewLog Server

The ViewLog Server is designed for remote playback function. This server allows you to remotely access the recorded files saved at the GV-Video Server and play back video with the player ViewLog.

Select **Enable** to activate the built-in server. Keep the default port **5552** or modify it if necessary. For details on the remote playback, see *5.2.2 Playback Using Remote ViewLog*.

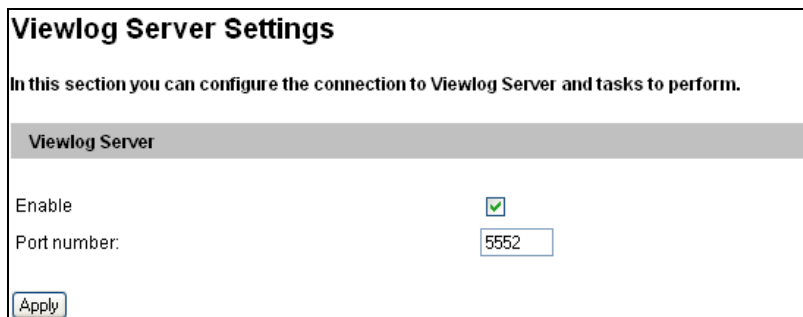

**Viewlog Server Settings**

In this section you can configure the connection to Viewlog Server and tasks to perform.

**Viewlog Server**

Enable

Port number:

Figure 4-25

### 4.3.9 3GPP

The 3GPP Server enables video and audio streaming to your 3G-enabled mobile phone.

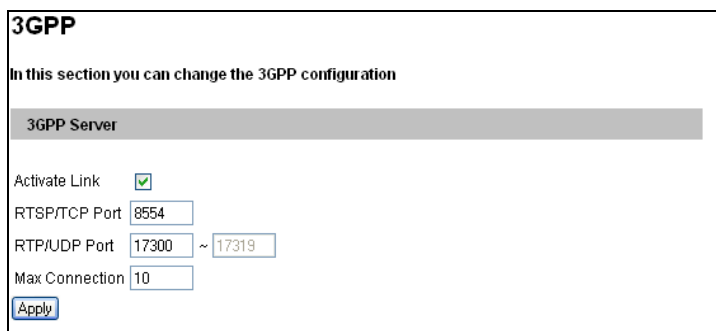

**3GPP**

In this section you can change the 3GPP configuration

**3GPP Server**

Activate Link

RTSP/TCP Port

RTP/UDP Port  ~

Max Connection

Figure 4-26

- **Activate Link:** Enable the 3GPP service.
- **RTSP/TCP Port:** Keep the default value 8554, or modify it if necessary.
- **RTP/UDP Port:** Keep the default range from 17300 to 17319, or modify it if necessary. The number of ports for use is limited to 20.
- **Max Connection:** Set the maximum number of connections to the GV-Video Server. The maximum value is 20.

For details on remote monitoring with mobile phones, see *10.4 3G Mobile Phone*.



## 4.4 Monitoring

You can start recording manually, by schedule or by input trigger.

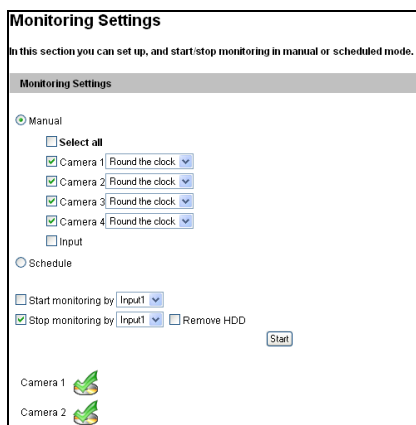

Figure 4-27

**[Manual]** Manually activates motion detection and input monitoring. Select one of the following options and then click the **Start** button.

- **Select all:** Manually starts recording and input monitoring as well.
- **Camera x:** Manually starts recording. Select the desired camera and the recording mode for recording.
- **Input:** Manually starts input monitoring. When the input is triggered, its associated camera and output will also be activated for recording and alerting. For input settings, see 4.2.2 *Input/Output Settings*.

**[Schedule]** The system starts recording and input monitoring based on the schedule you set. For schedule settings, see 4.5 *Recording Schedule*.

**[Start monitoring by Input X]** Starts monitoring by the assigned input. When the assigned input is triggered, the system will respond based on your recording or input monitoring settings in above **Manual** or **Schedule** options.

**[Stop monitoring by Input X]** Stops monitoring by the assigned input. When the assigned input is triggered, the system will stop monitoring.

- **Remove HDD:** When the monitoring is stopped by the input trigger, the hard disk will also be removed from the system for recording.

### [Camera Status Icon]



: Manual recording



: Schedule recording



: On standby



: Enabled for motion detection and input trigger

## 4.5 Recording Schedule

The schedule is provided to activate recording and I/O monitoring on a specific time each day.

### 4.5.1 Recording Schedule Settings

You can set up different monitoring schedules for each camera.

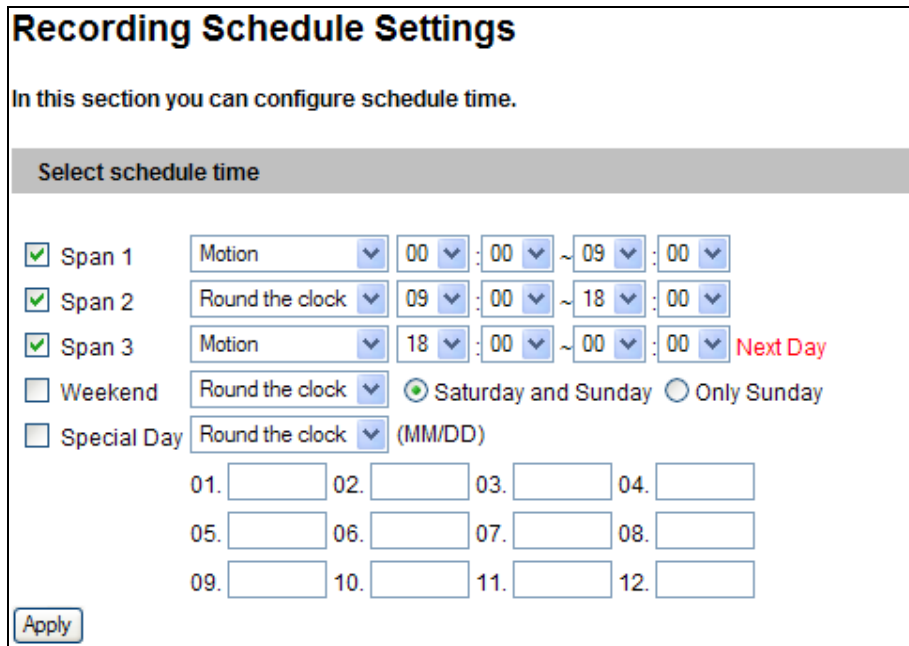

Figure 4-28

- **Span 1- Span 3:** Set a different recording mode for each time frame during the day. Each day can be divided into 3 time frames, represented by Span 1 to Span 3. The time frame settings will work from Monday through Sunday.
- **Weekend:** Enable this option to have a whole-day monitoring on the weekend and select a recording mode to be used. Define whether your weekend includes **Saturday and Sunday** or **Only Sunday**.
- **Special Day:** Set the recording mode on a specified day.

---

**Note:** In Recording Schedule and I/O Monitoring Schedule, if the settings for Special Day conflict with those for Span 1-3 or Weekend, the Special Day settings will get priority.

---

## 4.5.2 I/O Monitoring Settings

You can set the schedule for I/O monitoring to start.

Figure 4-29

- **Span 1-3:** Set different time frames during the day to enable I/O monitoring. Each day can be divided into 3 time frames, represented by Span 1 to Span 3. The time frame settings will work from Monday through Sunday.
- **Weekend:** Enable this option to have a whole-day monitoring on the weekend and select whether your weekend includes **Saturday and Sunday** or **Only Sunday**.
- **Special Day:** Enable I/O monitoring on a specified day.

## 4.6 Remote ViewLog

With the Remote ViewLog function, you can play back the files recorded at the GV-Video Server over TCP/IP network.

For the first-time user, you need to install the Remote ViewLog program from the Software DVD. For remote access to the GV-Video Server, the **ViewLog Server** built in the unit must be enabled. See 4.3.6 *ViewLog Server*.

For details on connecting to the GV-Video Server for playback, see 5.2.2 *Playback Using Remote ViewLog*.

## 4.7 Network

The Network section includes some basic but important network configurations that enable the GV-Video Server to be connected to a TCP/IP network.

### 4.7.1 LAN

According to your network environment, select among Static IP, DHCP and PPPoE.

### LAN Configuration

In this section you can configure videosever to work inside of LAN.

**LAN Configuration**

**Wired Ethernet** Select this option to use wired 10/100Mbps ethernet  
 **Wireless** Select this option to use Wireless

**LAN Configuration**

**Dynamic IP address** Select this option to obtain IP address from a DHCP server  
 **Static IP address** Select this option to enter a Static IP address manually  
 **PPPoE** Select this option to establish a DSL connection

Username:   
 Password:

**Configure connection parameters**

IP address:   
 Subnet Mask:   
 Router/Gateway:   
 Primary DNS server:   
 Secondary DNS server:  (Optional)

Figure 4-30

#### [LAN Configuration]

According to the network environment, select **Wired** or **Wireless**.

Before enabling **Wireless**, set up **WLAN Configuration** first. For details, see 4.7.2 *Wireless-Client Mode*.

**[LAN Configuration]**

- **Dynamic IP address:** The network environment has a DHCP server.

This option should only be enabled if you know which IP address the GV-Video Server will get from the DHCP server, or you have obtained a domain name from the DDNS service provider that always links to the unit's changing IP address.

- **Static IP address:** Assign a static IP or fixed IP to the GV-Video Server. Type the GV-Video Server's TCP/IP and DNS parameters in the "Configure connection parameters" section below.
- **PPPoE:** The network environment is xDSL connection. Type the Username and Password provided by ISP to establish the connection.

If you use the xDSL connection with dynamic IP addresses, you must use the DDNS function to obtain a domain name linking to the unit's changing IP address first.

**[Configure connection parameters]**

Type the GV-Video Server's IP address, Subnet Mask, Router/Gateway, Primary DNS server and Secondary DNS server.

Parameters	Default
IP address	192.168.0.10
Subnet Mask	255.255.255.0
Router/Gateway	192.168.0.1
Primary DNS server	192.168.0.1
Secondary DNS server	192.168.0.2

For details on Dynamic DNS Server Settings, see *4.7.3 Advanced TCP/IP*.

## 4.7.2 Wireless-Client Mode

To use the wireless function, a wireless LAN USB adaptor is required. For supported wireless LAN adaptors, see *Appendix A*.

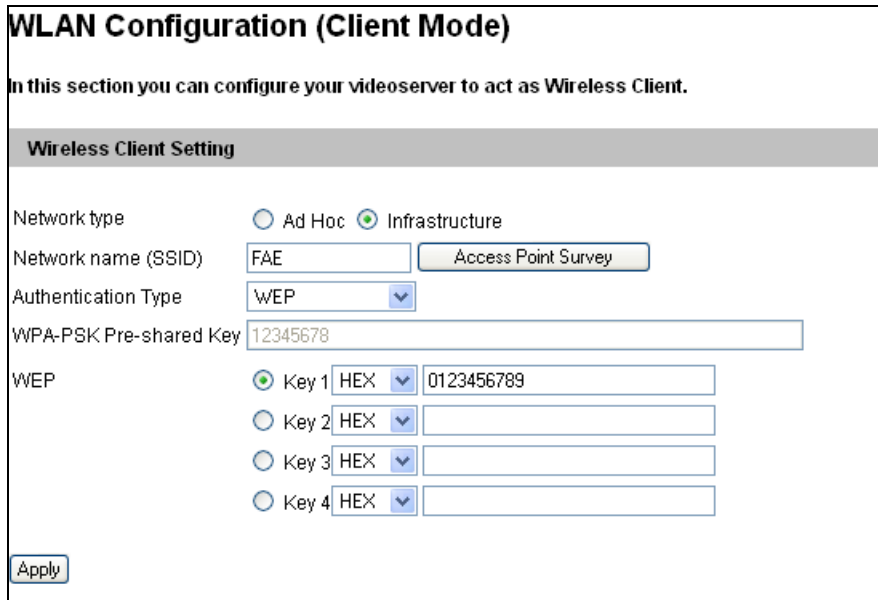

Figure 4-31

- **Network type:** Select the network mode **Ad Hoc** or **Infrastructure**.
  - ⊙ **Infrastructure:** Via the Access Point to connect to the Internet. This mode further gives wireless access to the Internet or data sharing under a previously wired environment.
  - ⊙ **Ad-Hoc:** A Peer-to-Peer mode. This mode connects to other computer with the WLAN card, and does not need the Access Point to connect to each other.
- **Network name (SSID):** The SSID (Service Set Identify) is a unique name that identifies a particular wireless network. Type SSID of the Wireless LAN group or Access Point you are going to connect to.
  - ⊙ **Access Point Survey:** Click this button to search all the available Access Points (Infrastructure mode) and wireless stations (AD-Hoc mode) within the range of your WLAN card.
- **Authentication Type:** Select one of these network authentications and data encryptions: **Disable**, **WEP**, **WPAPSK-TKIP**, **WPAPSK-AES**, **WPA2PSK-TKIP** or **WPA2PSK-AES**.
  - ⊙ **Disabled:** No authentication is needed within the wireless network.

- ⦿ **WEP (Wired Equivalent Privacy):** A type of data encryption. Type up to four WEP Keys in HEX or ASCII format. Note that if you use HEX format, only digits 0-9 and letters A-F, a-f are valid.
- ⦿ **WPAPSK-TKIP** and **WPA2PSK-TKIP:** Type WPA-PSK (Pre-Shared Key) for data encryption.
- ⦿ **WPAPSK-AES** and **WPA2PSK-AES:** Type WPA-PSK (Pre-Shared Key) for data encryption.

---

**Note:** Your encryption settings must match those used by the Access Points or wireless stations with which you want to associate.

---

### 4.7.3 Advanced TCP/IP

This section introduces the advanced TCP/IP settings, including DDNS Server, HTTP port, streaming port and UPnP.

#### Advanced TCP/IP

**Dynamic DNS Server Settings**

**In this section you can configure your video server to obtain a domain name by using a dynamic IP.**

Enable

Service Provider: GeoVision DDNS Server ex: [Register GeoVision DDNS Server](#)

Host Name: username.djmap.com

User Name:  

Password:  

Update Time: [Refresh](#)

Apply

**HTTP Port Settings**

**In this section you can change the default HTTP port number (80) to any port within the range 1024-65535. It is a simple method to increase system security using port mapping. You can configure HTTP connection to an alternative port.**

HTTP Port: 80

Apply

**Video Server Streaming Port Settings**

**In this section you can configure Streaming connection from a determine port. The default setting is 10000.**

VSS Port: 10000

Apply

**UPnP Settings**

**In this section you can enable or disable UPnP function.**

UPnP:  Enable  Disable

Apply

Figure 4-32

#### [Dynamic DNS Server Settings]

DDNS (Dynamic Domain Name System) provides a convenient way of accessing the GV-Video Server when using a dynamic IP. DDNS assigns a domain name to the GV-Video Server, so that the Administrator does not need to go through the trouble of checking if the IP address assigned by DHCP Server or ISP (in xDSL connection) has changed.



Before enabling the DDNS function, the Administrator should have applied for a Host Name from the DDNS service provider's website. There are 2 providers listed in the GV-Video Server: GeoVision DDNS Server and DynDNS.org.

**To enable the DDNS function:**

1. **Enable:** Enable the DDNS function.
2. **Service Provider:** Select the DDNS service provider you have registered with.
3. **Host Name:** Type the host name used to link to the GV-Video Server. For the users of GeoVision DDNS Server, it is unnecessary to fill the field because the system will detect the host name automatically.
4. **User Name:** Type the user name used to enable the service from the DDNS.
5. **Password:** Type the password used to enable the service from the DDNS.
6. Click **Apply**.

**[HTTP Port Settings]**

The HTTP port enables connecting the GV-Video Server to the web. For security integration, the Administrator can hide the server from the general HTTP port by changing the default HTTP port of 80 to a different port number within the range of 1024 thru 65535.

**[Video Server Streaming Port Settings]**

The VSS port enables connecting the GV-Video Server to the GV-System. The default setting is 10000.

**[UPnP Settings]**

UPnP (Universal Plug & Play) is a networking architecture that provides compatibility among networking equipment, software and peripherals of the 400+ vendors that are part of the Universal Plug and Play Forum. It means that they are listed in the network devices table for the operating system (such as Windows XP) supported by this function. Enabling this function, you can connect to the GV-Video Server directly by clicking on the GV-Video Server listed in the network devices table.

## 4.7.4 UMTS

UMTS stands for Universal Mobile Telephone System. UMTS is a third-generation (3G) broadband, packet-based transmission of text, digitized voice, video, and multimedia at data rates up to 2 megabits per second. UMTS offers a consistent set of services to mobile computer and phone users, no matter where they are located in the world.

After a mobile broadband device (supporting UMTS, HSDPA, etc.) is attached to the USB port on the rear panel and the UMTS function is enabled, the GV-Video Server can have wireless broadband access. For supported mobile broadband devices, see *Appendix B*.

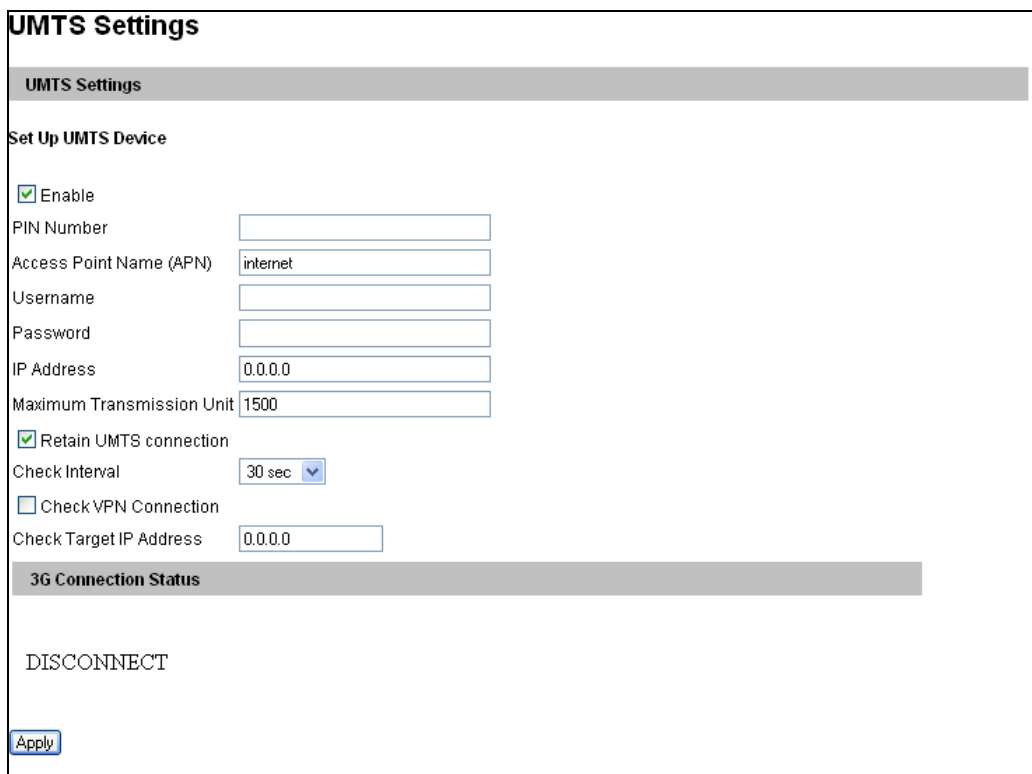

Figure 4-33

- **PIN number:** Type the PIN number that is provided by your network operator.
- **Access Point Name (APN):** Type Access Point Name that is provided by your network operator.
- **Username:** Type a valid username to enable the UMTS service from your network operator.
- **Password:** Type a valid password to enable the UMTS service from your network operator.

- **IP Address:** The IP address of the GV-Video Server will be displayed after enabling the UMTS service. The next time when you want to log in the GV-Video Server, you need to enter the IP address into your browser. If you use the UMTS connection with dynamic IP addresses, first use the DDNS function to get a domain name linking to the GV-Video Server's changing IP address. For details on the DDNS, see *4.7.3 Advanced TCP/IP*.
- **Maximum Transmission Unit:** Type the Maximum Transfer Unit (MTU). The default value is 1500.
- **Retain UMTS Connection:** Select this option to check the UMTS connection status and use the drop-down list to specify the desired time length for check frequency. The GV-Video Server will rebuild the connection if disconnection is detected.
- **Check VPN Connection:** (Note this option is only available for GV-VS02A, GV-VS04A and GV-VS12.) Select this option to check the VPN (Virtual Private Network) connection status. To check the IP address, type the target IP address in the **Check Target IP Address** field.
- **3G Connection Status:** (Note this option is only available for GV-VS02A, GV-VS04A and GV-VS12.) Indicates the connection status of UMTS or VPN.

### 4.7.5 Multicast

Note this function is only available for **GV-VS02** (Firmware Version 1.46), **GV-VS02A** (Firmware Version 1.01 or later) and **GV-VS04A**.

The multicast provides a mechanism for sending a single video and audio stream to a group of hosts. Only the hosts that have joined a multicast group can send and receive the multicast streams. The multicast streams are only sent to hosts on a local network.

This configuration page provides two settings. One is to allow the GV-Video Server to join a multicast group. The other is to allow the GV-Video Server to receive audio broadcasting from other hosts in a multicast group.

---

**IMPORTANT:** For GV-VS02 users, the Multicast function only works when the video resolution is set to CIF (720 x 480 / 720 x 576) or QCIF (720 x 480 De-Interface / 720 x 576 De-Interface).

---

### Multicast Settings

In this section you can configure the multicast settings of the video server.

**Multicast Settings (Only Support CIF or QCIF Resolution)**

Enable:

Multicast Host Name:

Multicast Info Update Period:  seconds

Multicast Data IP:

Multicast Data Port:

Multicast Video: Camera 1  Camera 2

Multicast Audio: Camera 1  Camera 2

Enable Encryption

Encryption Key:

Enable Audio Callback

Assign IP to receive Audio:

Assign Port to receive Audio:

Figure 4-34

- **Multicast Host Name:** Name the GV-Video Server in a multicast group.
- **Multicast Info Update Period:** Set the time length between each update of multicast streams.
- **Multicast Data IP:** Type the IP address used for multicasting. The default IP address is 224.1.1.2.
- **Multicast Data Port:** Type the port used for multicasting. The default value is 8300.
- **Multicast Video:** Select the camera to send its video through multicasting.
- **Multicast Audio:** Select the audio to send its audio through multicasting.
- **Enable Encryption:** Enable this option and type the Encryption Key to secure multicast streams. The hosts in the multicast group will need to enter the Key to access the video and audio streams.
- **Enable Audio callback:** Enable this option to receive audio broadcasting from hosts in the multicast group. Specify the IP address and port number to receive the audio broadcast. The default IP address is 224.1.1.3 and port number is 8400.

To perform the multicast and listen to audio broadcasting, see *4.1.1 Multicast*.

### 4.7.6 IP Filter

The Administrator can set IP filtering to restrict access to the GV-Video Server.

#### IP Filter Setting

IP Filtering

In this section you can allow or deny network connection listed in the table.

Enable IP Filtering

No.	IP Address Range in CIDR format	Action	Customize
The IP Filter has not been configured yet			

Filtered IP:  (ex: 192.168.0.0/24)

Action to take:

Figure 4-35

To enable the IP Filter function:

1. **Enable IP Filtering:** Enable the IP Filtering function.
2. **Filtered IP:** Type the IP address you want to restrict the access.
3. **Action to take:** Select the action of **Allow** or **Deny** to be taken for the IP address(es) you have specified.
4. Click **Apply**.

## 4.8 Management

The Management section includes the settings of data and time, USB mass storage device and user account. Also you can view the firmware version and execute certain system operations.

### 4.8.1 Date and Time Settings

The date and time settings are used for date and time stamps on the image.

#### Date and Time Settings

In this section you can configure time and date or just synchronize with a NTP server.

**Date and Time on Videosever**

Wed Jan 19 08:48:48 2000

**Time Zone**

(GMT+08:00) China, Hong Kong, Australia Westem, Singapore, Taiwan, Russia ▾

Enable Daylight Saving Time

Start  (MM/dd/hh/mm)

End  (MM/dd/hh/mm)

**Synchronized with a Network Time Server**

Synchronized with Network Time Server (NTP)

Host name or IP Address:

Update period: 24 hours; Update Time: AM 05:10

**Synchronized with your computer or modify manually**

Modify manually

Date  (yyyy/mm/dd)

Time  (hh:mm:ss)

Synchronized with your computer

**Date and time overlay setting**

Show date as  ▾

(This is a format of date where yyyy stands for year in 4 digits or yy in 2 digits, mm stands for month, and dd stands for day)

Display order

Date prior to time (Ex.2007/05/21 17:00:00)

Time prior to date(Ex.17:00:00 2007/05/21)

Figure 4-36

**[Date & Time on Video server]** Displays the current date and time on the GV-Video Server.

**[Time Zone]** Sets the time zone for local settings. Select **Enable Daylight Saving Time** to automatically adjust the GV-Video Server for daylight saving time. Type the Start Time and End Time to enable the daylight saving function.

Also see *5.2.4 Playback of Daylight Saving Time Events*.

**[Synchronized with a Time Server]** By default, the GV-Video Server uses the timeserver of [time.windows.com](http://time.windows.com) to automatically update its internal clock every 24 hours. You can also change the host name or IP setting to the timeserver of interest.

**[Synchronized with your computer or manually]** Manually changes the GV-Video Server's date and time. Or, synchronize the GV-Video Server's date and time with those of the local computer.

**[Date and time overlay setting]** Select the display format of date and time stamps on the image. For this function to work, you must also enable the **Overlaid with date stamps** and **Overlaid with time stamps** options in Figure 4-3.

## 4.8.2 GPS Maps Settings

Note this function is only available for **GV-VS02** (Hardware Version 2.0), **GV-VS02A**, **GV-VS04A** and **GV-VS12**.

The GV-Video Server supports the Global Position System (GPS) for active vehicle tracking and location verification. The vehicle location will be tracked by Google Maps. Before using the Google Maps, you must sign up for a Google Maps API key. Then, enter the registered Maps API Key, the longitude and latitude of the GV-Video Server, and location name to enable this function.

If your GV-Video Server is installed on an active vehicle, it is not necessary to enter **Longitude** and **Latitude**, since the vehicle location will be traced by GPS. However, if your GV-Video Server has a fixed position without GPS function, then it is required to enter its **Longitude** and **Latitude** so its correct location can be displayed on the Google Maps.

### GPS Maps

In this section you can configure the GPS Maps settings.

#### GPS Maps Settings

Sign up for a Google Maps API key [Link to the Google Maps API](#)

Google Maps API Key	<input type="text"/>	
Longitude	<input type="text" value="121.56443"/>	(Ex.121.565=E121.565. -10.25=W10.25)
Latitude	<input type="text" value="25.03367"/>	(Ex.25.081=N25.081. -10.25=S10.25)
Location Name	<input type="text" value="Taipei 101"/>	

Figure 4-37

For details on the GPS application, see 6.3 *GPS Tracking*.



### 4.8.3 Storage Settings

Based on Linux ext3 file system, the GV-Video Server supports external USB mass storage devices for video and audio recording. Normally USB mass storage devices are ready for Windows OS. Therefore, you need to format the devices by using the following Storage Settings. After being formatted, the storage devices will be ready to use by Linux OS of the GV-Video Server.

## Storage Settings

In this section you can configure the disk storage to archive videos and events.

### Storage Settings

Enable recycling

Stop recording or recycle disk when free space of disk is smaller than  ▼

Keep days (1-255)

### Disk Information

Disk No.	Total Size	Used Size	Free Size	Utilization	Remove	Format
USB0	704.172	86.327	617.845	12%	<input type="button" value="Remove"/>	<input type="button" value="Format"/>

### Partition Information

Disk No.	Partition No.	Total Size	Used Size	Free Size	Utilization	Format
USB0	5	201.590	85.942	115.648	42%	<input type="button" value="Format"/>
USB0	6	201.590	0.129	201.461	0%	<input type="button" value="Format"/>
USB0	7	201.590	0.128	201.462	0%	<input type="button" value="Format"/>
USB0	8	99.402	0.128	99.274	0%	<input type="button" value="Format"/>

(Unit: Gigabyte)

Figure 4-38

#### [Storage Settings]

If the **Enable recycling** option is checked, when the space of the USB mass storage device is lower than the specified space, the system will either write the data to another device or overwrite the oldest recorded files.

If the **Enable recycling** option is not checked, the system will stop recording when the specified space is reached.

- **Keep days (1-255):** Specify the number of days to keep the files from 1 day to 255 days. When both **Keep days** and **Enable recycling** are selected, the system applies whichever condition comes first. For example, if the specified smallest amount of storage space comes earlier than the designated keep days, then recycle is applied first.

#### **[Disk Information]**

This section shows the details of the attached storage devices.

#### **[Partition Information]**

This section shows the partition details of the attached storage devices.

#### **To add a USB mass storage device:**

1. Attach the device to the GV-Video Server.
2. Click the **Format** button.

After the format is complete, the partition information will display. The maximum space for one partition is 200 GB.

#### **To remove a USB mass storage device:**

1. Click the **Remove** button.
2. When you are prompted to ensure the action, click **Yes**. The page will be refreshed and the partition information will be cleaned.
3. Remove the device from the GV-Video Server.

---

#### **Note:**

1. If **Enable Recycle** is selected, the available space of the USB mass storage device must be higher than the space you specified at the **Stop recording or recycle disk when free space of disk is smaller than x** option. Otherwise no video will be recorded.
  2. The recording data may be lost if you remove the USB mass storage device during recording.
  3. If you do not remove the USB storage device properly, the data cannot be read in another computer. In this case, re-plug the storage device back to the GV-Video Server. The system will repair the data automatically. When the system is repairing the data, the Remove field will display "Repairing".
-

### 4.8.4 User Account

You can change the login name and password of Administrator, Guest and FTP Server User.

- The default Administrator login name and password are **admin**.
- The default Guest login name and password are **guest**. To allow a Guest user log in without entering name and password, select **Disable authentication for guest account**.
- The default FTP Server login name and password are **videosever**.

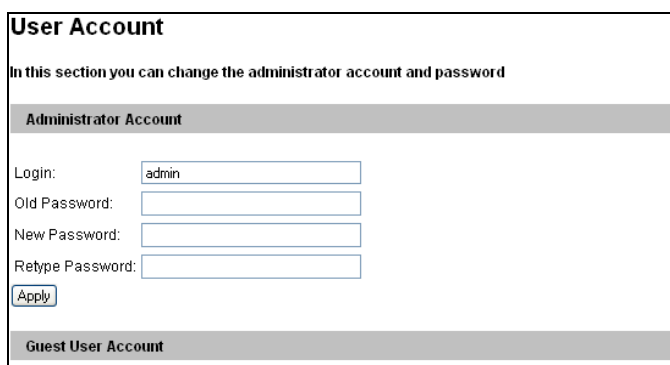

The screenshot shows a web interface titled "User Account". Below the title is a subtitle: "In this section you can change the administrator account and password". The interface is divided into two sections: "Administrator Account" and "Guest User Account". The "Administrator Account" section contains four input fields: "Login:" with the value "admin", "Old Password:", "New Password:", and "Retype Password:". Below these fields is an "Apply" button. The "Guest User Account" section is currently empty.

Figure 4-39

## 4.8.5 Log Information

The **System Booting Time History** section contains every start time of the GV-Video Server. The start time is recorded on the hard disk, so the information is only available when a hard disk is attached to the GV-Video Server.

The **System Log** section contains dump data that is used by service personnel for analyzing problems.

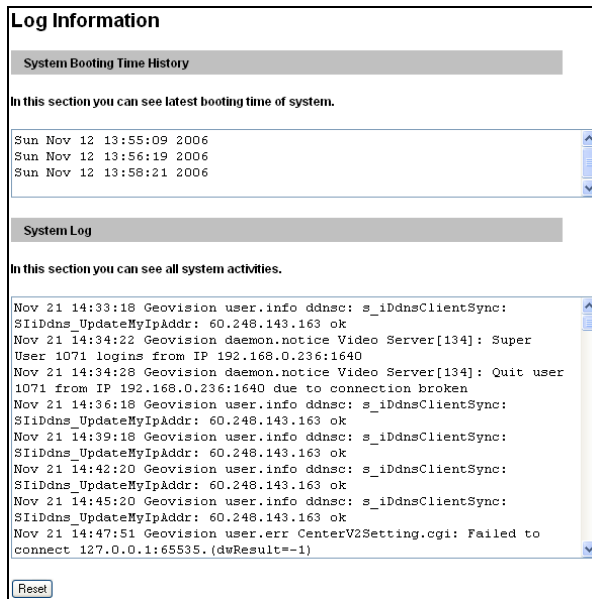

Figure 4-40

## 4.8.6 System Log

Note the function is only available on **GV-VS02A** (Firmware Version 1.01 or later), **GV-VS04A** and **GV-VS12** (Firmware Version 1.02 or later).

The System Log records the events in the four types of logs: **System Event**, **Monitoring Event**, **I/O Event** and **Login/Logout Event**. With the System Log, you can search and obtain the detailed information of an event. To use the System Log, a hard disk is required to connect to the GV-Video Server.

1. For the first-time user of the System Log, first click **Create** to create a system log database (access file) on the attached hard disk.

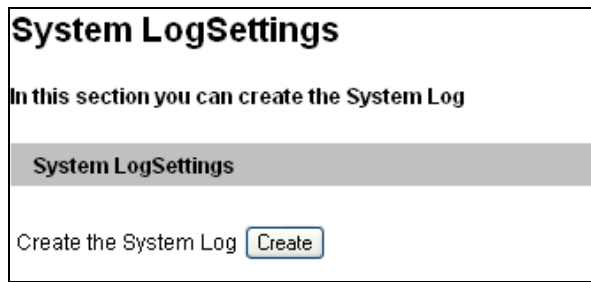

Figure 4-41

---

**Note:** If you have created the System Log on the hard disk, clicking **Create** again will clean your System Log.

---

2. Select the log type **System Event, Monitoring Event, I/O Event** or **Login/Logout** from the left menu of the Web interface.
3. Select the filtering criteria. For example, we want to know the login and logout information during a specific period of time.
4. Click **Query**. The filtering results may look like the figure below.

Login / Logout Query						
Device Name	<input checked="" type="checkbox"/> GV-VS04A	Status	Select all			
Mode	Select all	Time	2009-10-29 00:00:00 ~ 2009-10-29 23:59:59			
Login / Logout	Select all	User Name	<input type="text"/>			
DST	Select all					
<input type="button" value="Query"/> <input type="button" value="Reset"/>						
The page show record 1-2, total number of records :2 total number of pages :1						
Query Result List						
Device Name	User Name	Login / Logout	Time	Mode	Status	DST
GV-VS04A	admin	Login	2009-10-29 19:07:36	Local	Success	N
GV-VS04A	admin	Logout	2009-10-29 19:07:27	Local	Success	N
<input type="button" value="Export CSV"/> <input type="button" value="Export Word"/>						

Figure 4-42

## 4.8.7 Tools

This section allows you to execute certain system operations and view the firmware version.

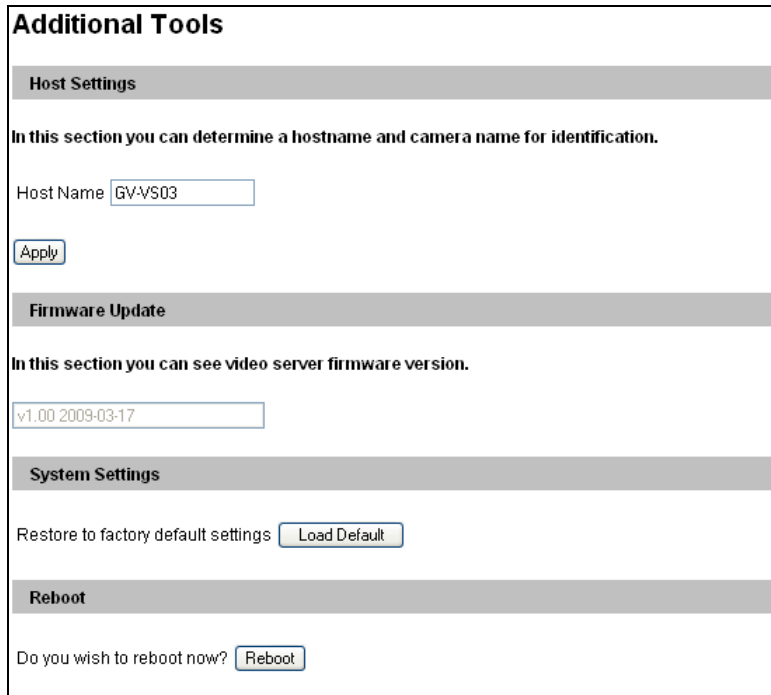

**Additional Tools**

**Host Settings**

In this section you can determine a hostname and camera name for identification.

Host Name

**Firmware Update**

In this section you can see video server firmware version.

**System Settings**

Restore to factory default settings

**Reboot**

Do you wish to reboot now?

Figure 4-43

**[Host Settings]** Enter a descriptive name for the GV-Video Server.

**[Firmware Update]** This field displays the firmware version of the GV-Video Server.

**[System Settings]** Clicking the **Load Default** button will make the GV-Video Server restore factory default settings. The Ready LED on the front panel will turn off. Wait until the Ready LED turns on and re-log in the server.

---

**Note:** After applying the default function, you will need to configure the GV-Video Server's network setting again.

---

### **[Reboot]**

Clicking the **Reboot** button will make the GV-Video Server perform the software reset. The Ready LED on the front panel will turn off. Wait until the Ready LED turns on and re-log in the server.

# Chapter 5 Recording and Playback

The GV-Video Server can record down video/audio directly to the attached USB mass storage device. And you can play back the recorded files on the GV-System or over the TCP/IP network.

## 5.1 Recording

To enable the recording function:

1. Attach the USB mass storage device to the GV-Video Server. See *4.8.3 Storage Settings*.
2. If you like to set up the pre-recording, post-recording or audio recording, see *4.1.2 Video Settings*.
3. If you like to set up the schedule for video recording or I/O monitoring, see *4.5 Recording Schedule*.
4. If you like to configure the areas and sensitivity values for motion detection, see *4.1.3 Motion Detection*.
5. If you want the recording to be triggered by input device, configure the operation of I/O devices. See *4.2.2 Input/Output Settings*.
6. To start recording and I/O monitoring, see *4.4 Monitoring*.

The GV-Video Server will start recording in case of motion detection, I/O trigger, or during the scheduled time.

## 5.2 Playback

Two methods are available to play back the video files recorded at the GV-Video Server:

- Playback using the USB mass storage device by attaching it directly to the GV-System
- Playback using the Remote ViewLog function over the TCP/IP network

## 5.2.1 Playback Using USB Mass Storage Device

You can play back the files recorded at the GV-Video Server by attaching the USB mass storage device to the GV-System. However, the GV-System is run on Windows system while the files recorded at GV-Video Server is of Linux file system. To enable Windows to recognize the files, you need to install the program **Ext2 Installable File System** included on the Software DVD.

1. Insert the Software DVD, select **IFS Drives** and follow the onscreen instructions for installation.
2. Run **IFS Drives** from Control Panel, and assign the drive name(s) to each available partition in the USB mass storage device.

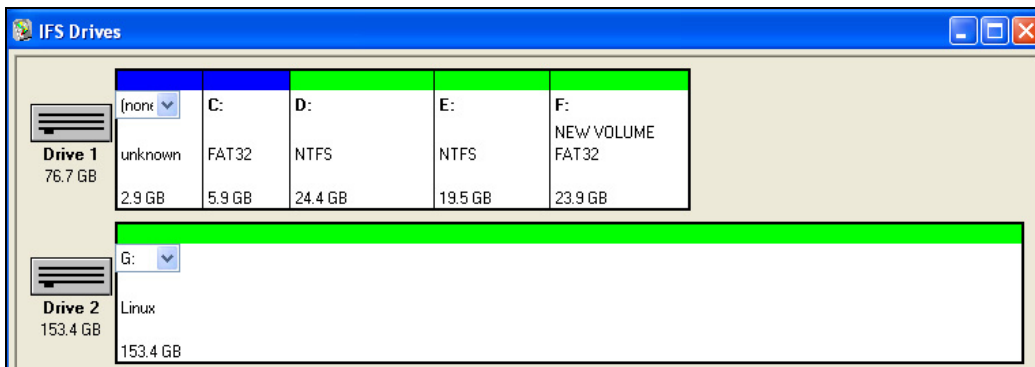

Figure 5-1

3. Run **ViewLog**.
4. Click the **Advanced** button , select **Reload Database** and click **Video Server/Compact DVR**. This dialog box appears.

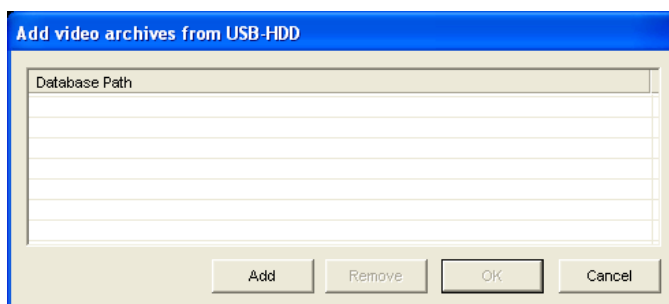

Figure 5-2

5. Click **Add** to assign the hard drive.
6. Click **OK** to load the data to the ViewLog for playback.



## 5.2.2 Playback Using Remote ViewLog

With the Remote ViewLog function, you can play back the files recorded at the GV-Video Server over TCP/IP network.

For remote playback, the GV-Video Server must allow the access with **ViewLog Server** activated ahead. See 4.3.8 *ViewLog Server*.

1. For the first time user, run the **Remote ViewLog** program from the Software DVD. Next time whenever you like to use this function, access this option from the GV-Video Server's web interface.
2. When this dialog box appears, type the GV-Video Server's IP address, login ID and password. Keep the default port **5552** or modify it if necessary.

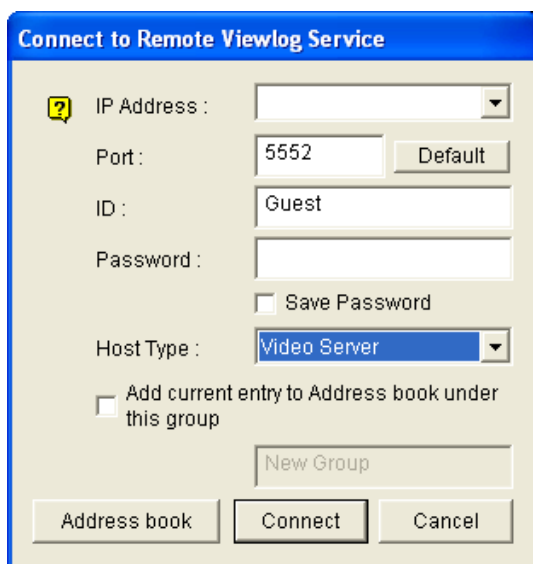

Figure 5-3

3. In the Host Type field, select **Video Server**.
4. Click **Connect** to access the files of the GV-Video Server for playback.

---

**Note:** For details on the Remote ViewLog, see the supplementary user's manual on the Software DVD.

---

### 5.2.3 Playback of GPS Tracks

On GV-System, you can retrieve the GPS tracks from GV-Video Server for playback. You can also attach the USB mass storage device with the GPS data to GV-System for playback.

The following instructions describe how to retrieve the GPS tracks from GV-Video Server over Internet. If you like to use the USB mass storage device for playback, first follow the instructions in *5.2.1 Playback Using USB Mass Storage Device* to load the data to ViewLog, and then follow Steps 4-7 below to play back GPS tracks.

1. The GV-Video Server must allow the remote access with **ViewLog Server** activated. See *4.3.8 ViewLog Server*.
2. To remotely connect to GV-Video Server from GV-System, click the **Tools** button and select **Remote ViewLog Service**. The Connect to Remote ViewLog Service dialog box appears.
3. Enter the connection information of the GV-Video Server, and click **Connect**. Once the connection is established, the video events will be displayed on the Video Events list.
4. To select a map API (Application Program Interface), click the **Tools** button and click **Select Map API**. This dialog box appears.

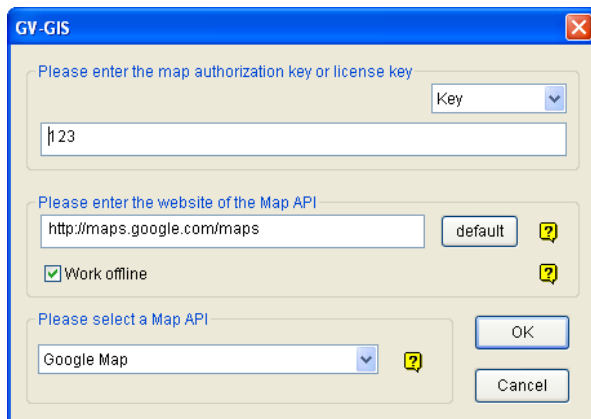

Figure 5-4

5. In **Please Select a Map API**, select a Map API. For Google Maps, you need to sign up for an API key from Google website (<http://code.google.com/apis/maps/signup.html>), and enter the API key in the **Please enter the map authorization key or license key** field.

6. To play back GPS tracks, click the **Tools** button and select **Display GIS Window**. The first-time user will be prompted for a License Agreement. Read through the license terms before you click **I understand and agree** to continue.
7. Select the events with GPS tracks from the Video Event list, select the desired video mode, and click the **Play** button to start.

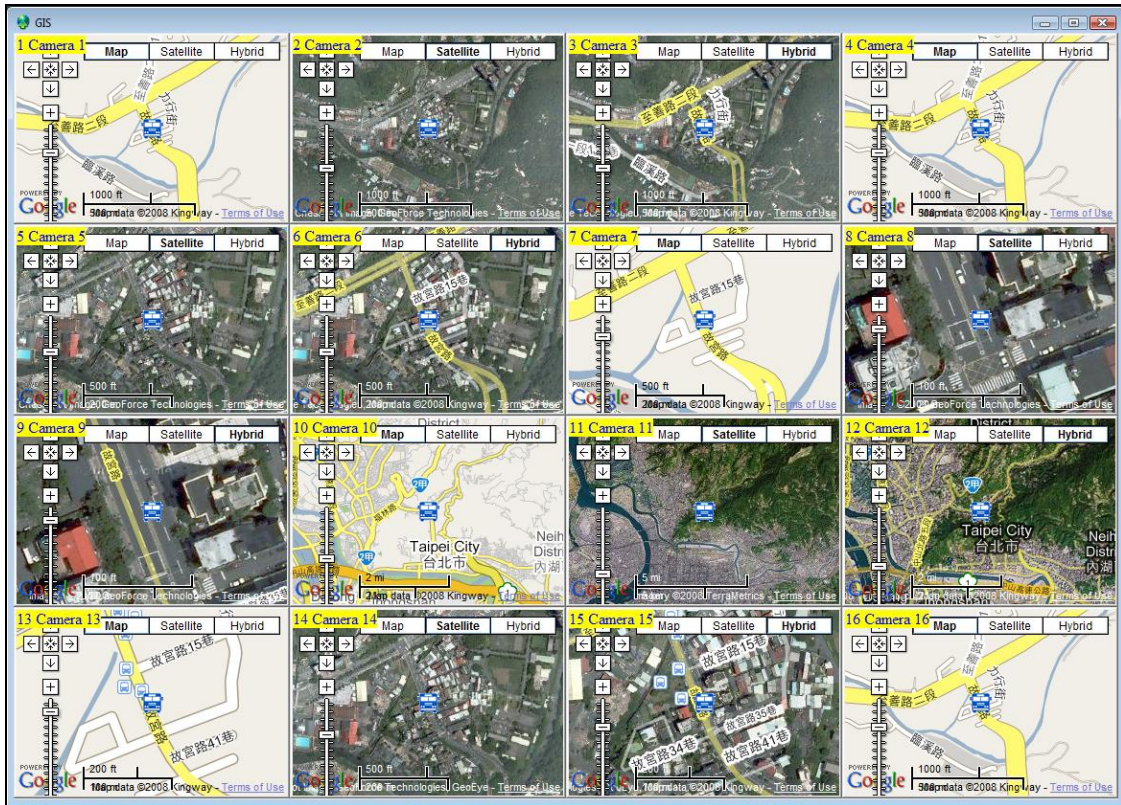

Figure 5-5

**Note:**

1. The playback function is only compatible with GV-System version 8.3 or later.
2. If you like to use the maps created yourself, overwrite the files at  
:\GV folder\GIShtm-User, and select **User Defined** from the “Please Select a Map API” drop-down list (Figure 5-4).
3. If you are the paid-client of Google Maps, select **Client** from the “Please enter the map authorization key or license key” drop-down list; otherwise select **Key**.

## 5.2.4 Playback of Daylight Saving Time Events

On GV-System, you can retrieve the events recorded during the Daylight Saving Time (DST) period from GV-Video Server for playback. You can also attach the USB mass storage device with the recorded files to GV-System for playback.

The following instructions describe how to retrieve the recorded files from GV-Video Server over Internet. If you like to use the USB mass storage device for playback, first follow the instructions in *5.2.1 Playback Using USB Mass Storage Device* to load the recorded files to ViewLog, and then follow Steps 4-7 below to play back DST events.

1. The GV-Video Server must allow the remote access with **ViewLog Server** activated. See *4.3.8 ViewLog Server*.
2. To remotely connect to GV-Video Server from GV-System, click the **Tools** button and select **Remote ViewLog Service**. The Connect to Remote ViewLog Service dialog box appears.
3. Enter the connection information of the GV-Video Server, and click **Connect**. Once the connection is established, the video events will be displayed on the Video Event list.
4. On the Date Tree, select the date of Daylight Saving Time. A separate DST subfolder will be displayed as illustrated below.

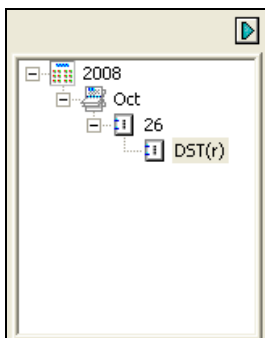

Figure 5-6

5. On the Video Event list, select desired events, and click the **Play** button to start.

---

### Note:

1. The playback function is only compatible with GV-System version 8.3 or later.
  2. The AVI file recorded during the DST period is named with the prefix "GvDST", e.g. GvDST20081022xxxxxxxxx.avi, to differentiate from the regular AVI file named with the prefix "Event", e.g. Event20081022xxxxxxxxx.avi.
-

# Chapter 6 Advanced Applications

This chapter introduces more advanced applications.

## 6.1 Upgrading System Firmware

GeoVision will periodically release the updated firmware on the website. The new firmware can be simply loaded into the GV-Video Server by using the Web interface or the **IP Device Utility** included on the Software DVD.

### Important Notes before You Start

Before you start updating the firmware, please read these important notes:

1. While the firmware is being updated,
  - A. the power supply must not be interrupted, and
  - B. do not unplug the Ethernet cable if the cable is the source of power supply (Power over Ethernet or PoE supported).
2. Do not turn the power off in 10 minutes after the firmware is updated.

---

**WARNING:** The interruption of power supply during updating causes not only update failures but also damages to your GV-Video Server. In this case, please contact your sales representative and send your device back to GeoVision for repair.

---

## 6.1.1 Using the Web Interface

1. In the Live View window, click the **Show System Menu** button (No. 11, Figure 3-2), select **Remote Config**, and then click the **Firmware Upgrade** tab. This dialog box appears.

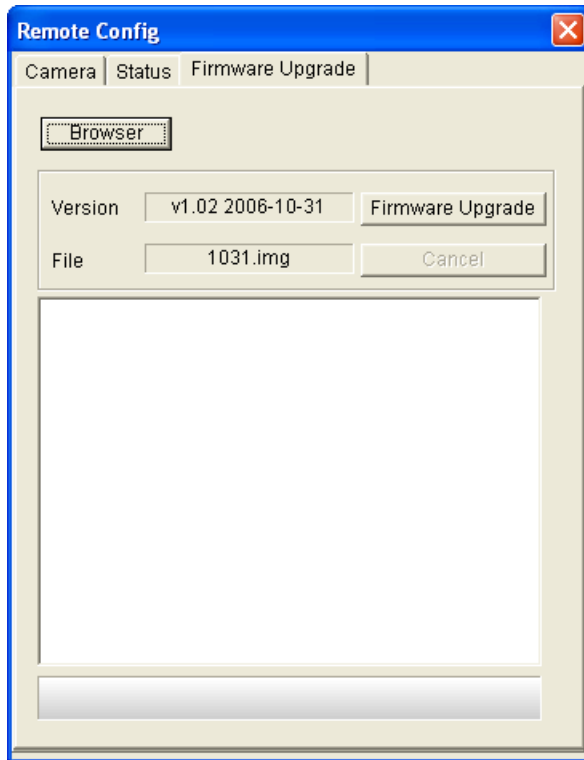

Figure 6-1

2. Click the **Browser** button to locate the firmware file (.img) saved at your local computer.
3. Click the **Firmware Upgrade** button to process the upgrade.

### 6.1.2 Using the IP Device Utility

The IP Device Utility provides a direct way to upgrade the firmware to multiple GV-Video Servers.

1. Insert the Software DVD, select **IP Device Utility**, and follow the onscreen instructions to install the program.
2. Double-click the **GV IP Device Utility** icon created on your desktop. This dialog box appears.

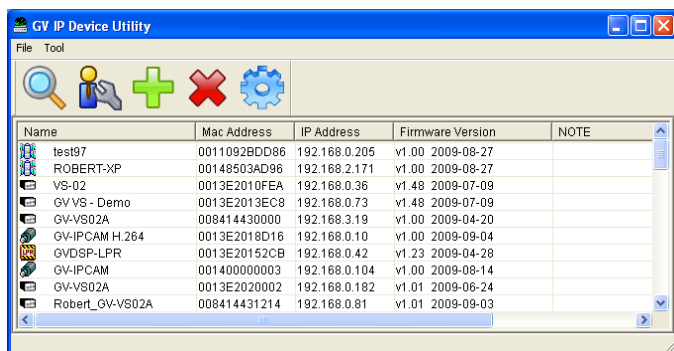



Figure 6-2

3. Click the **Search** button  to locate the available GV-Video Servers on the same LAN. Or click the **New** button and assign the IP address to locate a GV-Video Server over the Internet. Or highlight one GV-Video Server in the list and click the **Delete** button to remove it.
4. Double-click one GV-Video Server in the list. This dialog box appears.

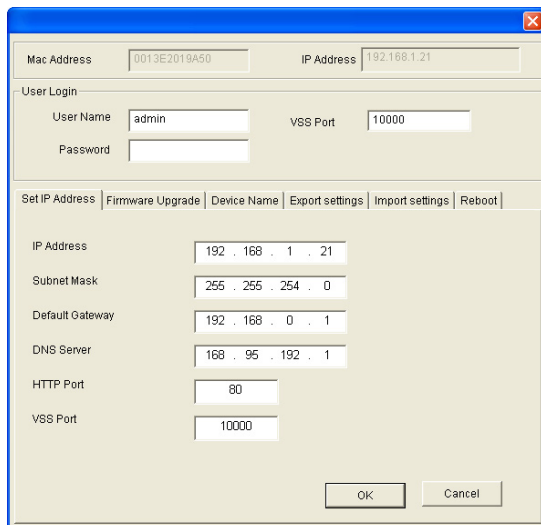

Figure 6-3

- Click the **Firmware Upgrade** tab. This dialog box appears.

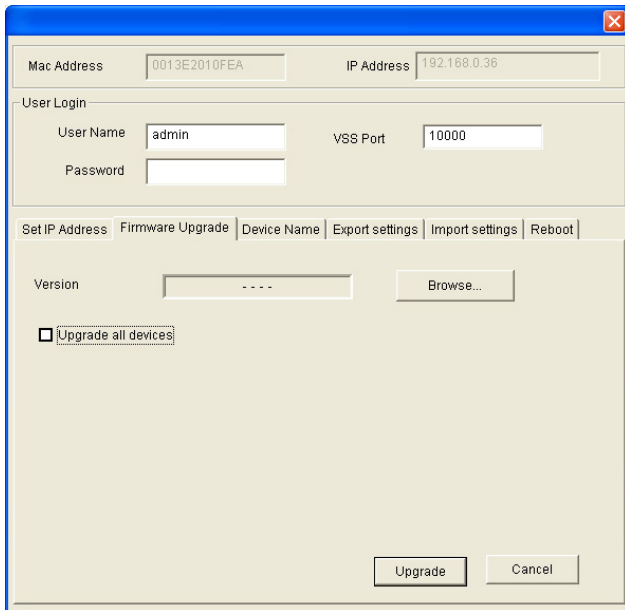

Figure 6-4

- Click the **Browse** button to locate the firmware file (.img) saved at your local computer.
- If you like to upgrade all the GV-Video Servers in the list, check **Upgrade all devices**.
- Type **Password**, and click **Upgrade** to process the upgrade.

## 6.2 Backing Up and Restoring Settings

With the IP Device Utility included on the Software DVD, you can back up the configurations in the GV-Video Server, and restore the backup data to the current unit or import it to another unit.

### 6.2.1 Backing Up the Settings

- Run **IP Device Utility** and locate the desired GV-Video Server. See Steps 1-3 in 6.1.2 *Using the IP Device Utility*.
- Double-click the GV-Video Server in the list. Figure 6-3 appears.



3. Click the **Export Settings** button. This dialog box appears.

Figure 6-5

4. Click the **Browse** button to assign a file path.
5. Type **Password**, and click **Export Settings** to save the backup file.

## 6.2.2 Restoring the Settings

1. In Figure 6-3, click the **Import Settings** tab. This dialog box appears.

Figure 6-6

2. Click the **Browse** button to locate the backup file (.dat).
3. Click **Update Settings** to start restoring.

## 6.3 GPS Tracking

Note this function is only available for **GV-VS02** (Hardware Version 2.0), **GV-VS02A**, **GV-VS04A** and **GV-VS12**.

The GV-Video Server supports the Global Position System (GPS) for active vehicle tracking and location verification. The vehicle location will be tracked by Google Maps.

To track the location of your GV-Video Server:

1. Connect the GV-GPS module or any GPS module to the terminal block on the rear panel of the unit. See *Chapter 9 Auxiliary Device Connectors*.
2. Enable the GPS function. See *4.2.3 GPS/Wiegand*.
3. Sign up for a Google Maps API key and enable the GPS Maps settings. See *4.8.2 GPS Maps Settings*.
4. Open the control panel of the Live View window.



Figure 6-7

- Click **Start** to activate GPS tracking. The longitude, latitude and host time of the GV-Video Server will be displayed.
- To save the location information to your local computer, select **Save message** and click [...] to assign the storage path.

- To track the GV-Video Server on maps, click **Open**. A warning message appears.

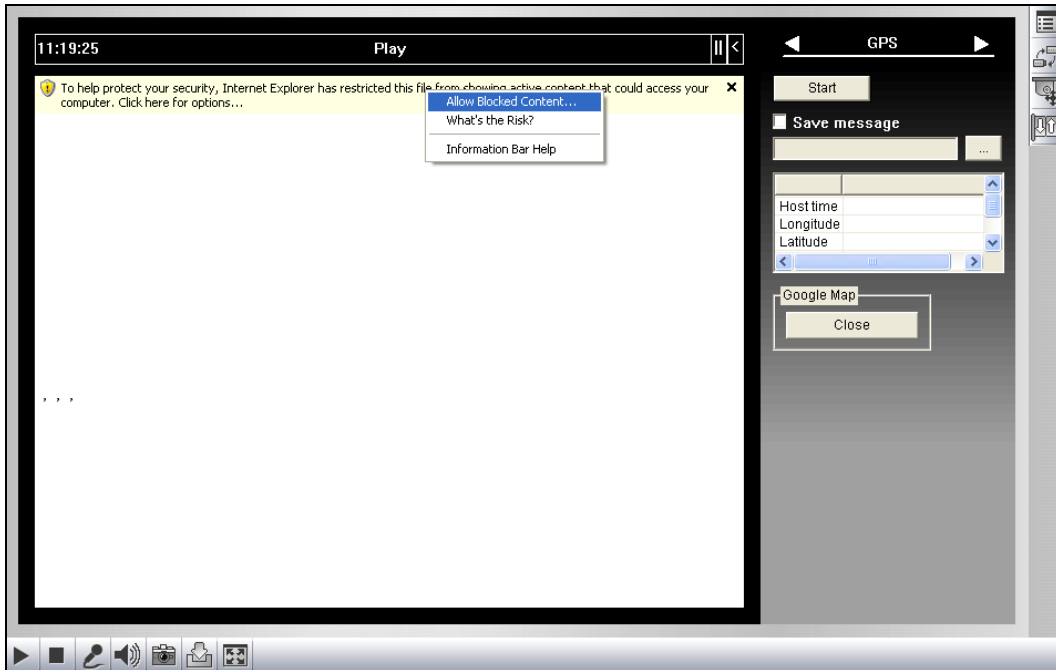



Figure 6-8

- Right-click the warning message and select **Allow Blocked Content**. The map will be displayed. The  icon indicates the location of your GV-Video Server. At the upper right corner you have options for viewing different map formats, such as Satellite and Hybrid.

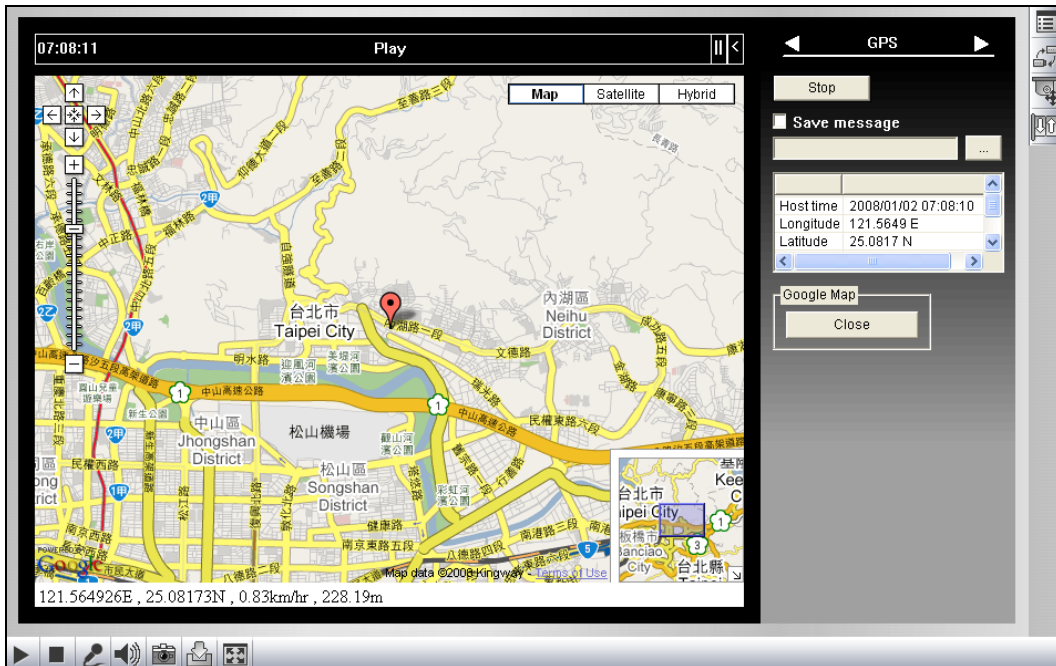

Figure 6-9

## 6.4 Restoring to Factory Default Settings

Among different models of GV-Video Server, the operation of restoring the GV-Video Server to original default values can vary and the way the LEDs flash can also be different.

To restore to default settings, use the **Reset** and **Load Default** buttons on the front panel. For the location of the two buttons see *1.6 Physical Description*.

### Restoring GV-VS02, GV-VS02A and GV-VS04A to Default Settings

1. Press and then release the **Reset** button immediately.
2. Press and hold the **Load Default** button until all 3 LEDs (Power, Ready and Disk Full/Fault) are on. This may take up to 30 seconds.
3. Release the **Load Default** button. The process of loading default values is complete, and the GV-Video Server starts rebooting itself with all 3 LEDs turning off.
4. Wait until the Power and Ready LEDs turn on again. After this all the settings are returned to default values.

### Restoring GV-VS12 to Default Settings

1. Unplug and plug the power cable to start.
2. Press and hold the **Default** button until the Ready LED blinks. This may take up to 30 seconds. The Ready LED will blink twice.
3. Release the **Default** button. The process of loading default values is complete, and the GV-Video Server starts rebooting itself with the 2 LEDs turning off.
4. Wait until the Power and Ready LEDs turn on again. After this all the settings are returned to default values.

---

**Note:** Before the **Ready LED** is on again, do not unplug the power cable; otherwise the loading of default values will fail.

---

## 6.5 Verifying Watermark

Note this function is only available for **GV-VS02A** (Firmware Version 1.01 or later), **GV-VS04A** and **GV-VS12** (Firmware Version V1.02 or later).

The watermark is an encrypted and digital signature embedded in the video stream during the compression stage, protecting the video from the moment of creation. Watermarking ensures that an image is not edited or damaged after it is recorded. To enable the watermark function, see [Watermark], *4.1.2 Video Settings*.

The **Watermark Proof** is a watermark-checking program. It can verify the authenticity of the recording before you present it in court.

### 6.5.1 Accessing AVI Files

To verify watermark, first you have to access the recorded AVI files by one of these methods:

1. Use the **File Save** function on the Live View window (Figure 3-3) to start recording on the local computer.
2. Use the **Act as FTP Server** function to download AVI files from the GV-Video Server. See *4.3.2 FTP*.
3. Use the files recorded on the USB storage device. Since the files saved on the USB storage device are of Linux file system, remember to run **IFS Drives** from the Software DVD to convert the Linux-based files to Windows-based files. For the instructions, see Steps 1 to 2 in *5.2.1 Playback Using USB Mass Storage Device*.

### 6.5.2 Running Watermark Proof

1. Install **Watermark Proof** from the Software DVD. After installment, a **WMPProof** icon is created on your desktop.
2. Double-click the created icon. The Water Mark Proof window appears.
3. Click **File** from the menu bar, select **Open** and locate the recording (.avi). The selected recording is then listed on the window. Alternatively, you can drag the recording directly from the storage folder to the window.
4. If the recording is unmodified, a message **Pass** would appear in the Check Sum section. If the recording is being modified or does not contain watermark, a message **No Pass** would appear. To review the recording, double-click the listed file on the window.

### 6.5.3 The Watermark Proof Window

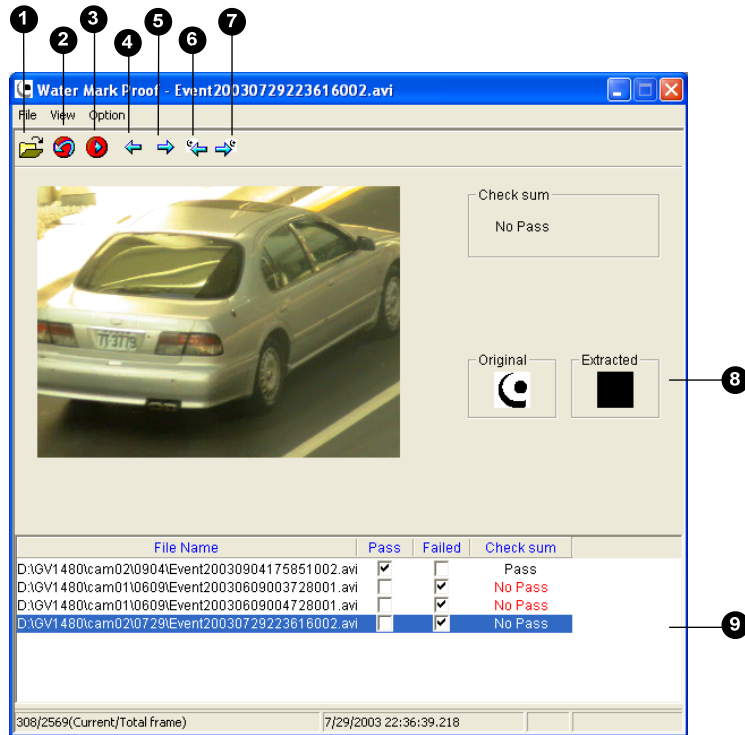

Figure 6-10

The controls in the window:

No.	Name	Description
1	Open File	Opens the recording.
2	First Frame	Goes to the first frame of the file.
3	Play	Plays the file.
4	Previous Frame	Goes to the previous frame of the file.
5	Next Frame	Goes to the next frame of the file.
6	Previous Watermarked Frame	Goes to the previous frame that contains watermark.
7	Next Watermarked Frame	Goes to the next frame that contains watermark.
8	Original vs. Extracted	The Extracted icon should be identical with the Original icon. If not, it indicates the recording has been tampered.
9	File List	Displays the proof results.

## Chapter 7 DVR Configurations

The GV-System provides hybrid solution, integrating the digital videos from GV-Video Server with other analog videos. For the digital videos, the GV-System provides the complete video management, such as video viewing, recording, playback, alert settings and almost every feature of the system. Following is the integration specifications:

- GV-System version 8.32 or later is required.
- The maximum number of connections to the GV-Video Server is 20. When one GV-System connects to one GV-Video Server, it takes up to 4 connections. When users connect to one GV-Video Server via browser, it takes up to 2 connections. When users operate the **Camera/Audio Control** on Center V2, it takes 1 connection.
- The codec and recording resolution of digital videos are set up on the GV-Video Server instead of on the GV-System.
- The hardware compression and the “Pre-Recording Using RAM” feature cannot work on the videos from GV-Video Server. For details about the “Pre-Recording Using RAM” feature, see “System Configuration”, Chapter 1, *User’s Manual* on the Surveillance System Software DVD.

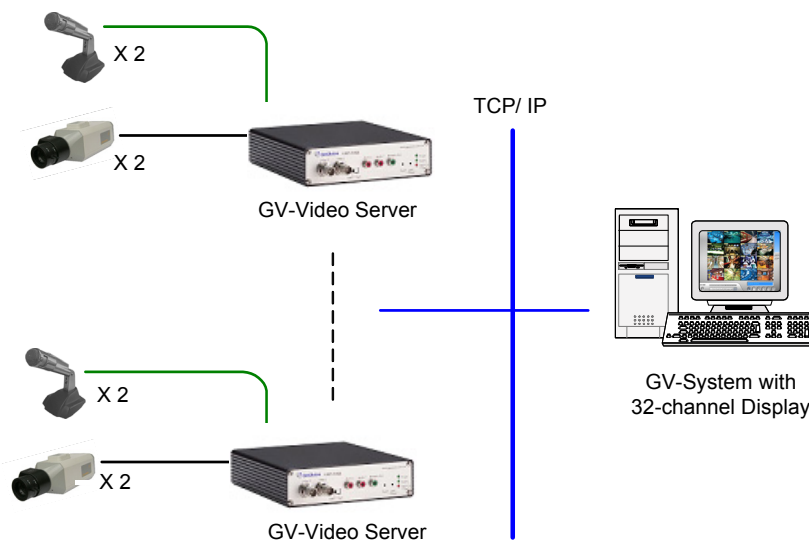

Figure 7-1

---

**Note:** Currently the GV-250 Card does not support the GV-Video Server.

---

## 7.1 Setting Up IP Cameras

To set up IP cameras on the GV-System, follow these steps:

1. On the main screen, click the **Configure** button, select **General Setting**, select **Camera / Audio Install** and click **IP Camera Install**. This dialog box appears.

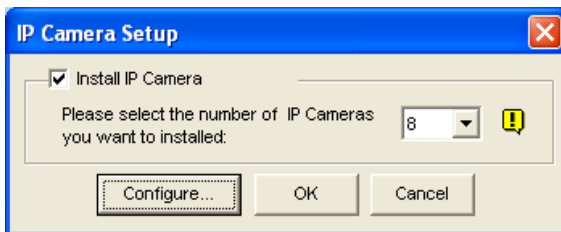

Figure 7-2

2. Select **Install IP Camera**, and select the number of IP Cameras you want to link to, and click **Configure**. This dialog box appears.

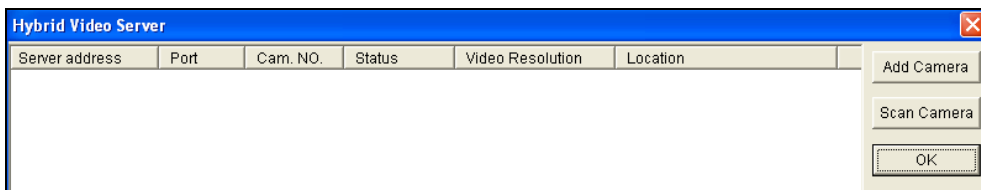

Figure 7-3

- To automatically set up the camera, click **Scan Camera** to detect any GV IP devices on the LAN.
- To manually set up the camera, click **Add Camera**.

The following steps are the example of manual setup.

3. Click **Add Camera**. This dialog box appears.



Figure 7-4



4. Type the IP address, username and password of the GV-Video Server. Modify the default HTTP port if necessary. Select **GeoVision** from the **Brand** drop-down list and select **GeoVision Video Server** from the **Device** drop-down list. This dialog box appears.

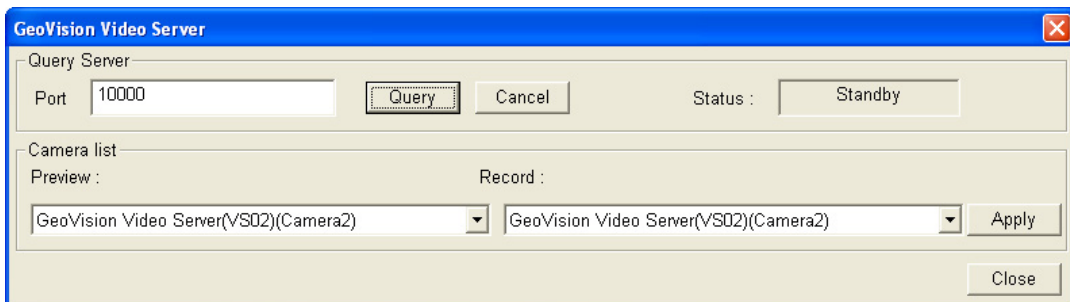

Figure 7-5

5. Click **Query** to detect the GV-Video Server. When it is detected, its available camera options will be displayed in the Camera List section.
6. Select the camera for live view from the **Preview** drop-down list, and the camera for recording from the **Record** drop-down list.
7. Click **Apply**, and then **Close** to exit the dialog box. The server information is displayed.

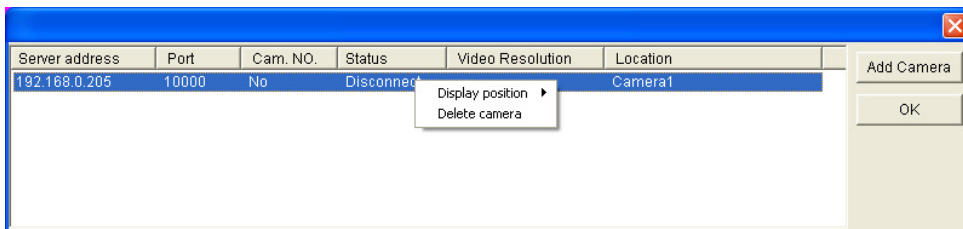

Figure 7-6

8. Click the server information, and select **Display Position** to map the IP camera to a channel on the GV-System.
9. The Statue column now should display “Connected”. Click **OK**.

## Previewing Video and Setting Audio

To preview video and activate audio recording, highlight the desired server (see Figure 7-6) and select **Preview & Audio Setting**. This dialog box appears.

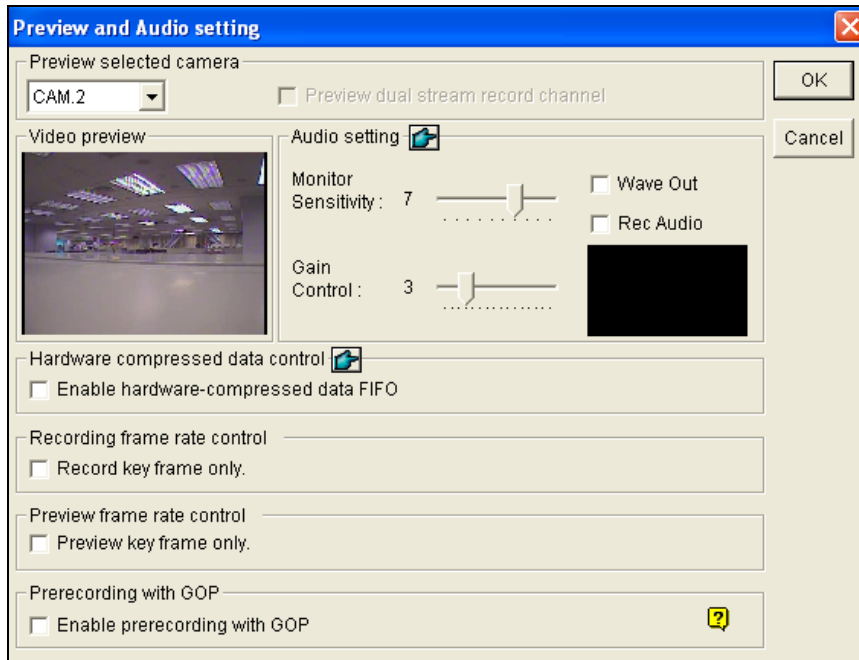

Figure 7-7

### [Preview selected camera]

- **Drop-down List:** Select the desired camera for live preview.
- **Preview dual stream record channel:** The option is only available when the dual stream is set, i.e. the cameras for live view and recording are configured differently (see Figure 7-5). Check this option for recording preview.

### [Audio Setting]

- **Monitor Sensitivity:** Adjust the sensitivity of the audio that will be detected. The higher the value, the more sensitive the system is to the surrounding sound.
- **Gain Control:** Increase or decrease the gain of the microphone.
- **Wave Out:** Select this option to listen to live audio from the GV-Video Server.
- **Rec Audio:** Select this option to activate the audio recording.

**[Hardware compressed data control]**

Hardware-compressed data from the video IP device, such as IP Camera, Video Server and Compact DVR, can be transmitted directly to remote servers instead of being compressed again on GV-System. The remote servers include Center V2, Control Center and WebCam. This function is useful when many remote servers access GV-System at one time. When the option is selected, it can reduce the system load on GV-System, and provide more frame rates and better image quality for each remote server.

---

**Note:** It is highly recommended to enable this function on a LAN environment because it requires a lot of bandwidth.

---

**[Recording Frame Rate Control]** Set the recording frame rate to meet your storage requirements.

- **Maximum recording frame rate:** This option is available when the recording codec of the IP camera is set to JPEG. Select the frame rate from 1 to 30 fps.
- **Recording key frame only:** This option is available when the recording codec of the IP camera is set to MPEG4 or H.264. You can choose to record key frames instead of all frames to save the storage space. This option is related to the GOP setting of the IP camera. For example, if the GOP value is set to 30, there is only one key frame among 30 frames. For the GOP setting, see *4.1.2 Video Settings*.

**[Preview Frame Rate Control]** Set the live view frame rate to reduce the CPU usage.

- **Maximum preview frame rate:** This option is available when the recording codec of the IP camera is set to JPEG. Select the frame rate of live view from 1 to 30 fps.
- **Preview key frame only:** This option is available when the recording codec of the IP camera is set to MPEG4 or H.264. Select this option to see the video of key frames only on the live view to reduce the CPU usage. This option is related to the GOP setting of the IP camera. For example, if the GOP value is set to 30, there is only one key frame among 30 frames. For the GOP setting, see *4.1.2 Video Settings*.

**[Prerecording with GOP]**

- **Enable prerecording with GOP:** Enable video recording before an event occurs. To enable this function, the three requirements must be met: D1 or CIF resolution, the number of frames in GOP set to 60 or less than 60 frames, MPEG4 ASP or H.264 codec.

## 7.2 Receiving Cardholder Data from Video Server

Over the network, GV-System can receive cardholder data from the Wiegand-interface card reader. This transmission is made possible through GV-Video Server.

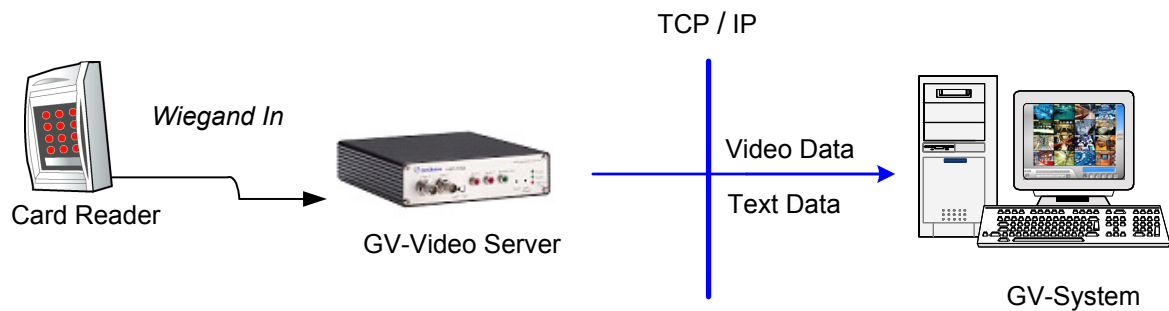

Figure 7-8

To receive cardholder data from Video Server, follow these steps:

1. Add the GV-Video Server to the GV-System. See 7.1 *Setting Up IP Cameras*.
2. Click the **Configure** button, point to **Accessories** and select **GV Wiegand Capture Device Setting**. The GV-Wiegand Capture Setup dialog box appears.
3. Click the **New** button. This dialog box appears.

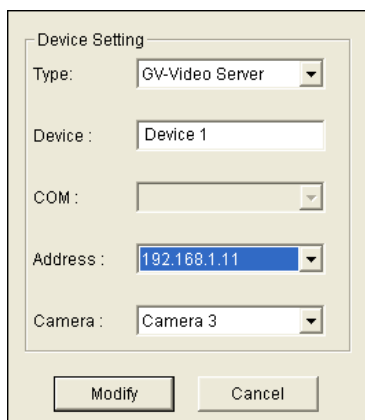

Figure 7-9

4. Select **GV-Video Server** from the Type drop-down list, enter a descriptive name for the Video Server, select the IP address of the video server from the Address drop-down list, and then select the camera to be mapped with.
5. Click **Add** to add the Wiegand card reader to the system.

- Note the cardholder data will not be overlaid on the mapped camera. To view cardholder data, click the **ViewLog** button, select **System Log** to display the Live Log Browser, and then click the **Device** tab.

ID	Time	Content	Event	Device	Camera
14158	11/23/2007 3:27:40 PM	Amy		Device1	Camera 1
14159	11/23/2007 3:27:40 PM	Engineer		Device1	Camera 1
14160	11/23/2007 3:27:40 PM		Stop Transaction	Device1	Camera 1
14161	11/23/2007 3:27:41 PM	00028036	Start Transaction	Device1	Camera 1
14162	11/23/2007 3:27:41 PM	Amy		Device1	Camera 1
14163	11/23/2007 3:27:41 PM	Engineer		Device1	Camera 1
14164	11/23/2007 3:27:41 PM		Stop Transaction	Device1	Camera 1
14165	11/23/2007 3:27:42 PM	00028036	Start Transaction	Device1	Camera 1
14166	11/23/2007 3:27:42 PM	Amy		Device1	Camera 1
14167	11/23/2007 3:27:42 PM	Engineer		Device1	Camera 1
14168	11/23/2007 3:27:42 PM		Stop Transaction	Device1	Camera 1
14169	11/23/2007 3:27:43 PM	00028036	Start Transaction	Device1	Camera 1
14170	11/23/2007 3:27:43 PM	Amy		Device1	Camera 1
14171	11/23/2007 3:27:43 PM	Engineer		Device1	Camera 1
14172	11/23/2007 3:27:43 PM		Stop Transaction	Device1	Camera 1
14173	11/23/2007 3:27:44 PM	00028036	Start Transaction	Device1	Camera 1
14174	11/23/2007 3:27:44 PM	Amy		Device1	Camera 1
14175	11/23/2007 3:27:44 PM	Engineer		Device1	Camera 1
14176	11/23/2007 3:27:44 PM		Stop Transaction	Device1	Camera 1
14177	11/23/2007 3:27:45 PM	00028036	Start Transaction	Device1	Camera 1
14178	11/23/2007 3:27:45 PM	Amy		Device1	Camera 1
14179	11/23/2007 3:27:45 PM	Engineer		Device1	Camera 1
14180	11/23/2007 3:27:45 PM		Stop Transaction	Device1	Camera 1

Figure 7-10

For the related settings on the GV-Video Server, see *Wiegand Function* in 4.2.3 *GPS/Wiegand*.

### 7.3 Remote Monitoring with Multi View

You can use the Multi View to monitor and manage the cameras and I/O devices connected to the GV-Video Server.

#### Connecting to GV-Video Server

The Multi View program is available in the GV-System applications, and also included on the Software DVD as an independent program. The following is an example of running the Multi View through WebCam Server on the GV-System.

- To enable the remote access to the GV-System, click the **Network** button, select **WebCam Server** to display the Server Setup dialog box, and click **OK** to start the WebCam server.
- At the local computer, open the Web browser and type the address of the GV-System. The Single View page appears.
- Select **Multi View** and the desired viewing resolution. The valid user name and password are required for login. For the first-time user, you will be directed to the Download page. Install the Multi View program before you can run it.

4. On the Multi View window, click the **Edit Host** button. The Edit Host window appears.
5. To create a host, click the **New** button. You need to create a group before creating a host.
6. Select **GV-Video Server** from the Device drop-down list. Type the host name, IP address, user name and password of the GV-Video Server. Modify the default VSS port **10000** if necessary.

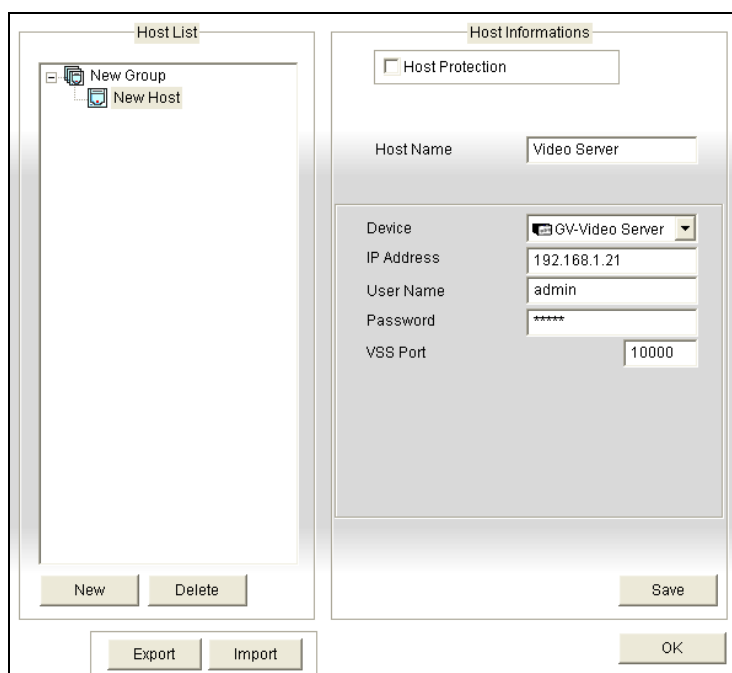

**Figure 7-11**

7. Click **Save** to establish connection.

For details on the Multi View functions, see “Multi View MPEG 4 Encoder Viewer”, Chapter 8, *User’s Manual* on the Surveillance System Software DVD.

## 7.4 Remote Monitoring with E-Map

You can use the Remote E-Map to monitor and manage the cameras and I/O devices connected to the GV-Video Server.

### Creating an E-Map for the GV-Video Sever

With the E-Map Editor, you can create an E-Map for the cameras and I/O devices connected to the GV-Video Server. The E-Map Editor is available in the two applications: Main System and E-Map Server. The following is an example of running the E-Map Editor included in the Main System.

1. Go to Windows **Start** menu, point to **Programs**, select **GV folder** and click **E-Map Editor**.
2. To create an E-Map, click the **Add Map** button on the toolbar. A New Map file appears.
3. Double-click the New Map file, and click the **Load Map** button on the toolbar to import a graphic file.
4. To create a host, click the **Add Host** button on the toolbar and select **Add Video Server**.
5. Right-click the created New Host in the Host View, and select **Host Settings**. This dialog box appears.

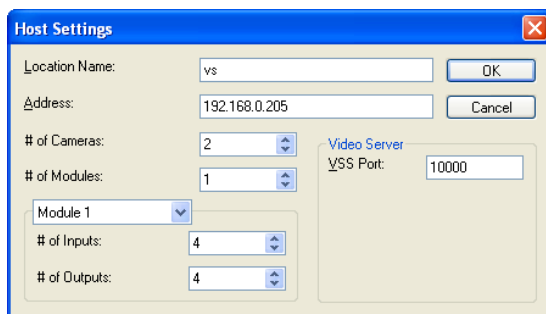

Figure 7-12

6. Give the GV-Video Server a location name, and type its IP address (or domain name). Keep the default VSS port **10000**, or modify it to match that of GV-Video Server.
7. Click **OK** to save the settings.
8. Expand the created host folder. Drag and drop the icons of cameras and I/O devices onto the imported E-Map.
9. Close the E-Map Editor. Click **Yes** when you are promoted to save the file.

For details on creating an E-Map file on the E-Map Server, see “E-Map Server”, Chapter 9, *User’s Manual* on the Surveillance System Software DVD.

### Connecting to GV-Video Server

Depending on where you save the created E-Map file (GV-System, E-Map Server or Control Center), the steps to open the Remote E-Map window for monitoring may vary slightly. The following is the connection example when you store the E-Map file in the GV-System.

1. To enable the remote access to the GV-System, click the **Network** button, select **WebCam Server** to display the Server Setup dialog box, and click **OK** to start the WebCam server.
2. At the local computer, open the web browser and type the address of the GV-System. The Single View page appears.
3. Select **Emap**. The valid user name and password are required for login. For the first-time user, you will be directed to the Download page. Install the E-Map program before you can run it.
4. On the Remote E-Map window, click the **Login** button and select the GV-Video Server host to access its videos and I/O devices. The valid user name and password are required to log in the GV-Video Server.

For details on the Remote E-Map functions, see “The Remote E-Map Window”, Chapter 9, *User’s Manual* on the Surveillance System Software DVD.



# Chapter 8 CMS Configurations

This section introduces the related settings to enable connecting to the GV-Video Server in the central monitoring stations Center V2, VSM and Dispatch Server.

## 8.1 Center V2

The Center V2 can monitor and manage the cameras and I/O devices connected to the GV-Video Server.

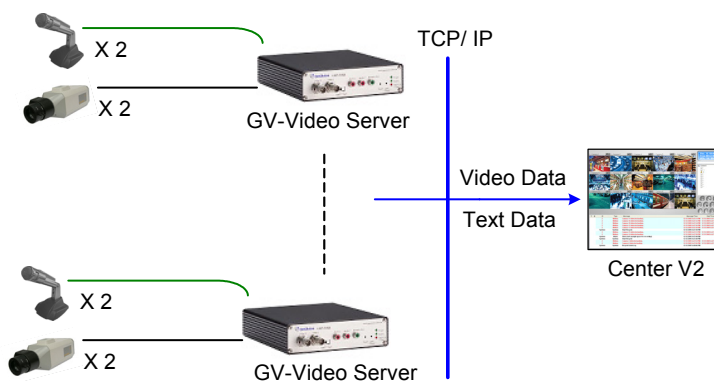

Figure 8-1

- To set the appropriate port connecting to the GV-Video Server, click the **Preference Settings** button, select **System Configure**, click the **Network** tab, and check **Accept connections from GV-Compact DVR, Video Server & IP Cam**. Keep the default port **5551** for the Port 2 option, or modify it to match the Center V2 port on the GV-Video Server.

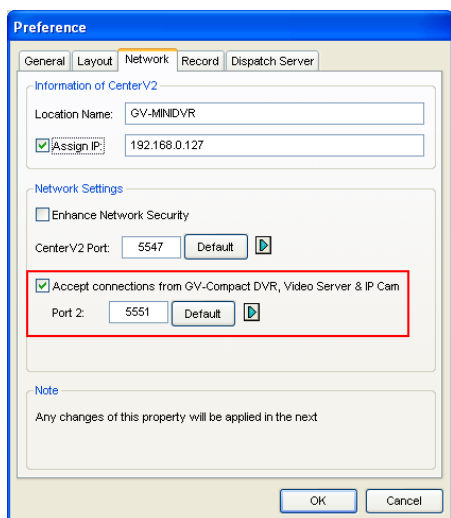

Figure 8-2

To define how to display the received video on motion detection and input trigger from the GV-Video Server, click the **Preference Setting** button and select **System Configure**. This dialog box appears.

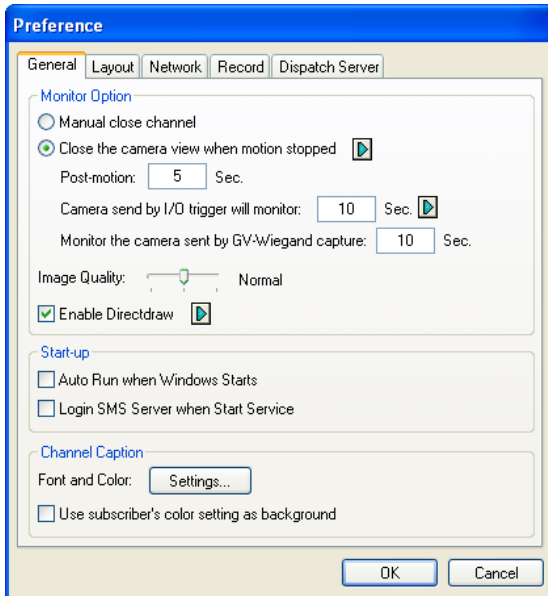

Figure 8-3

- **Manual close channel:** Closes the triggered camera view manually.
- **Close the camera view when motion stopped:** Closes the triggered camera view automatically when motion stops.
- **Post Motion:** Specify the duration of the camera view remaining on the monitoring window after motion stops.
- **Camera send by I/O trigger will monitor:** Specify the duration of the camera view remaining on the monitoring window when an I/O device is triggered.

To keep the camera view remaining on the monitoring window even after the alarm is finished, click the right-arrow button, and uncheck **Latch Trigger**. Then the camera view will keep remaining on the monitoring window for the specified time. For example, the alarm is triggered for 5 minutes and you set 10 minutes, which means the total display time will be 15 minutes.

- **Monitor the camera sent by GV-Wiegand Capture:** Specify the duration of the camera view remaining on the monitoring window when the card reader, connected to GV-Video Server, is triggered. For the related Wiegand settings on the GV-Video Server, see 4.2.3 *GPS/Wiegand*.

For further information on how to manage the received video from the GV-Video Server, see *GV-CMS Series User's manual*.

## 8.2 VSM

The VSM can monitor and manage the cameras and I/O devices connected to the GV-Video Server.

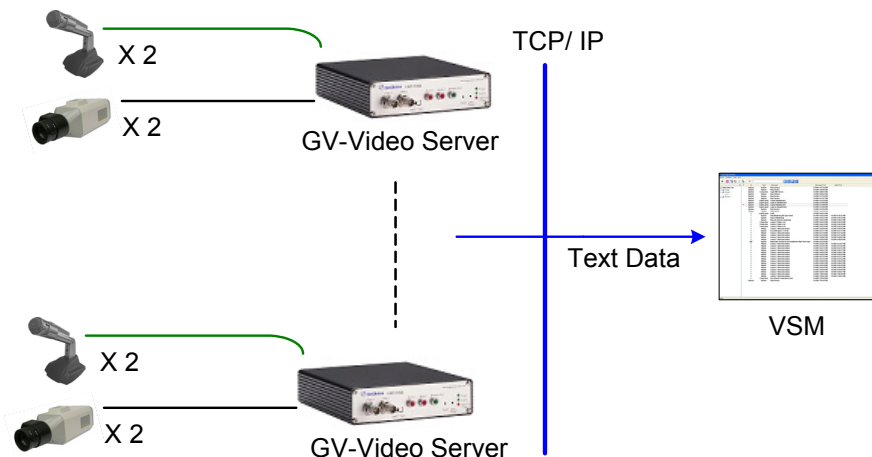

Figure 8-4

- To set the appropriate port connecting to the GV-Video Server, click **Configure** on the window menu, and select **System Configure** to display this dialog box. In the Connective Port field, keep the default value **5609** for the Port 2 option, or modify it to match the VSM port on the GV-Video Server.

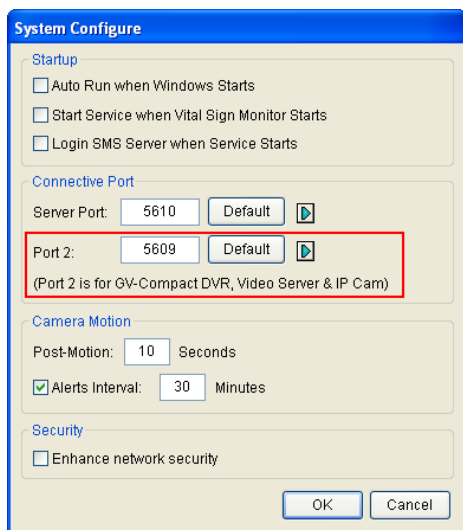

Figure 8-5

For further information on how to manage the received video from the GV-Video Server, see *GV-CMS Series User's manual*.

### 8.3 Dispatch Server

The Dispatch Server can manage the cameras and I/O devices connected to GV-Video Server, and distribute them to the Center V2.

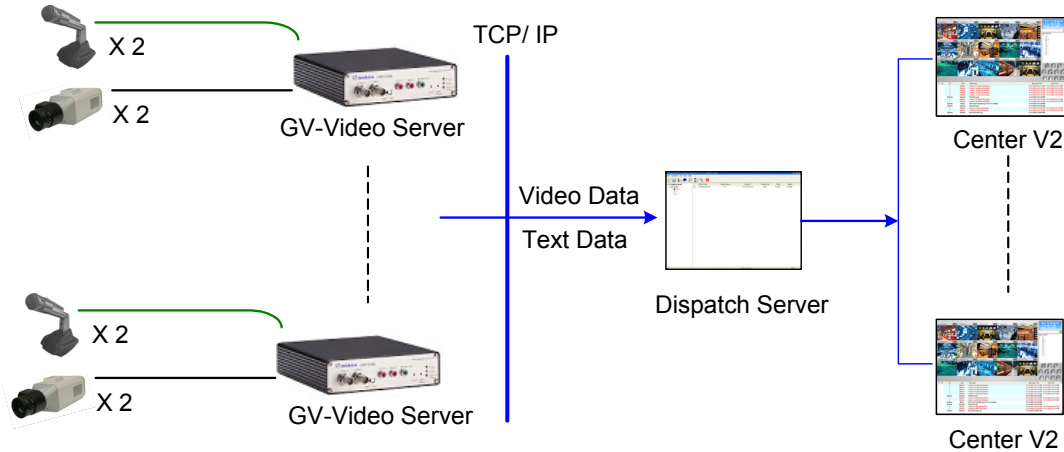

Figure 8-6

- To enable connecting to the GV-Video Server, click the **Server Setting** button on the toolbar, and enable **Allow Video Server Login as Subscriber from Port**. Keep the default port **5551**, or modify it to match the Center V2 port on the GV-Video Server.

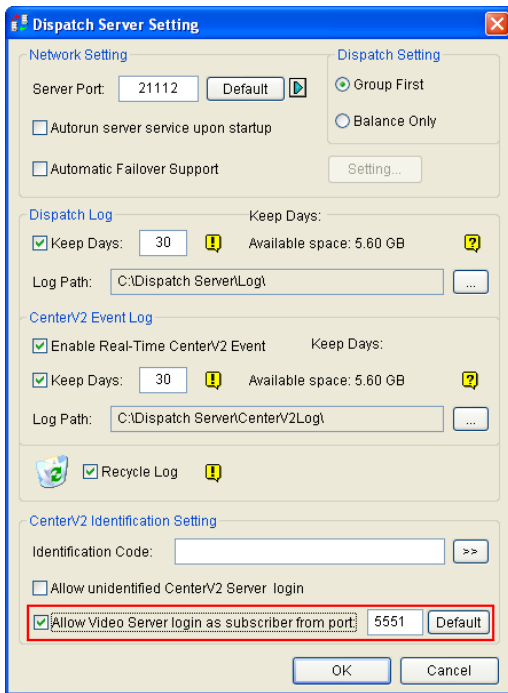

Figure 8-7

For further information on how to manage the received video from the GV-Video Server, see *GV-CMS Series User's manual*.

# Chapter 9 Auxiliary Device Connectors

## 9.1 GV-VS02, GV-VS02A and GV-VS04A

The 16-pin terminal block, located on the rear panel, provides interfaces for four digital inputs, four relay outputs, an RS-485 interface, a Wiegand interface, a GPS interface and auxiliary power. The terminal block can be used to develop applications for motion detection, event alerts via E-mail and FTP, center monitoring by Center V2 and VSM, PTZ control, Wiegand-interface card reader and a variety of other functions.

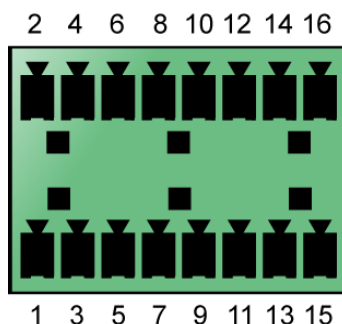

Figure 9-1

### 9.1.1 Pin Assignment

The table below lists the pin assignment for the terminal block.

Pin	Function	Pin	Function
1	Relay Output 1	9	DC 5V Out for GV-Relay Module, or GPS Module
2	Digital Input 1	10	Ground, or GPS Ground
3	Relay Output 2	11	RS 485+
4	Digital Input 2	12	Wiegand D0, or GPS RX
5	Relay Output 3	13	RS 485-
6	Digital Input 3	14	Wiegand D1, or GPS TX
7	Relay Output 4	15	Ground
8	Digital Input 4	16	DC 12V Out for Wiegand Card Reader

**Note:** For the GPS module, use the Pin 9 for power supply, Pin 10 for ground, Pin 12 for GPS RX and Pin 14 for GPS TX.

### 9.1.2 Relay Output

The relay outputs on the terminal block can only drive a maximum load of 5 volts. Working in conjunction with the GV-Relay V2 module, it can drive heavier loads. Refer to the figure and table below to connect the GV-Relay V2 module to the GV-Video Server.

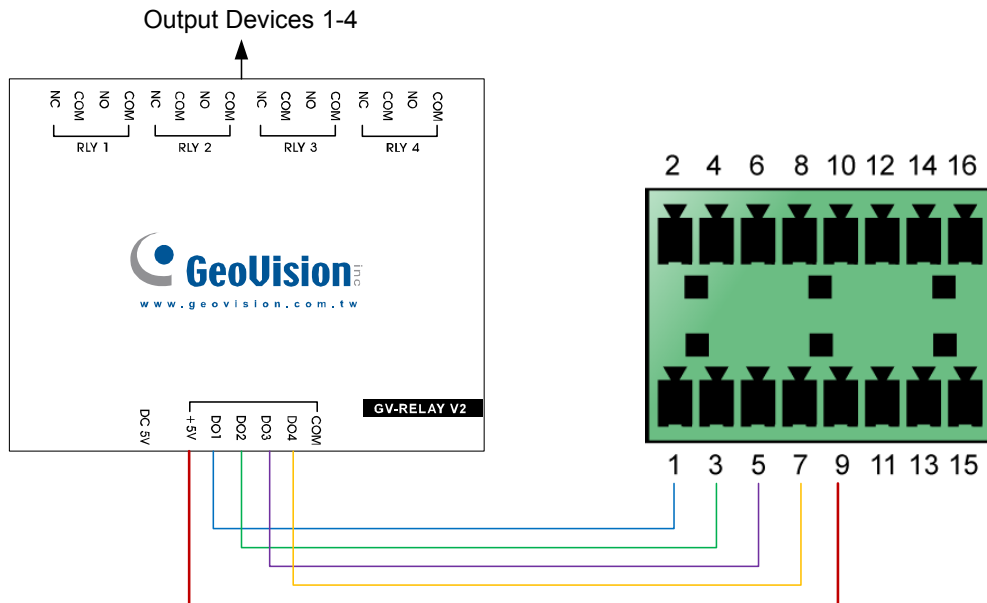

Figure 9-2

GV-Relay V2	I/O Terminal Block
DO 1	Pin 1
DO 2	Pin 3
DO 3	Pin 5
DO 4	Pin 7
+ 5V	Pin 9

Note that you don't need to use the DC 5V connector on the GV-Relay V2 module for power supply, since the power is supplied from the GV-Video Server.

---

**Note:** The GV-Relay module is an optional product.

---

## 9.2 GV-VS12

Owing to the model size, GV-VS12 provides the **I/O Cable with RJ-45 Connector** for the extensible connection to other I/O devices and PTZ cameras. A RJ-45 connector and a bundle of shielded wires are on the each end of the cable.

Strip the desired wires first, and connect the auxiliary devices with the right wires according to the following pin assignment in the section 9.2.1. Then insert the RJ-45 Connector to the I/O/PTZ Port on GV-VS12 (No. 4, Figure 1-9).

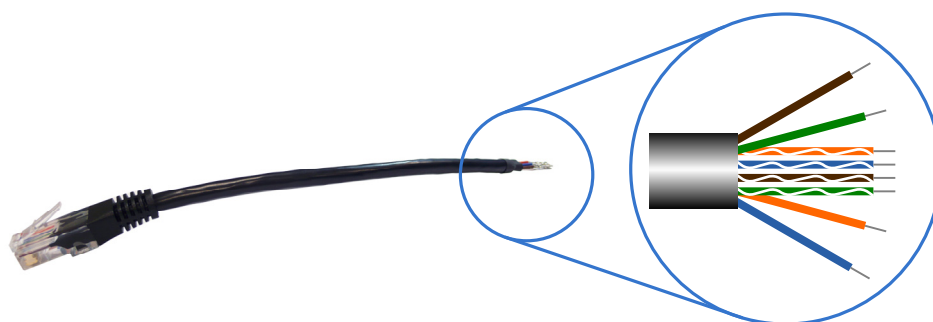

Figure 9-3

### 9.2.1 Pin Assignment

The table below lists the pin assignment for the shielded wires of the I/O Cable with RJ-45 Connector.

Pin	Wire	Function
1	Brown	Digital Out 1
2	White with Brown Stripe	Digital Out 2
3	White with Green Stripe	Ground
4	White with Blue Stripe	Digital In 1
5	Blue	Digital In 2
6	Green	Ground
7	Orange	RS-485 -
8	White with Orange Stripe	RS-485 +

## 9.2.2 RS-232 Terminal Block

The RS-232 terminal block on GV-VS12 is mainly used for the connection to a GPS module.

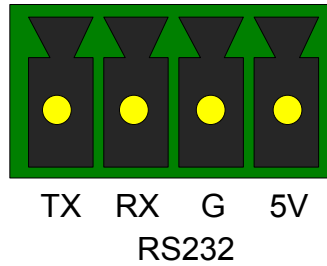

Figure 9-4

Pin	Function
TX	GPS RX (Receive)
RX	GPS TX (Transmit)
G	Ground
5V	DC 5V Out

---

**Note:** To ensure the connection to the GV-VS12, the GPS RX must be connected to the TX pin, and the GPS TX must be connected to the RX pin.

---



# Chapter 10 Mobile Phone Connection

Using a PDA, Smartphone or 3G-enabled mobile phone, you can receive live video streaming from the GV-Video Server. The chart below lists the GV mobile applications supporting the GV-Video Server.

Handheld Device View	OS Supported	Default Port	Settings on GV-Video Server
<b>GView V2</b>	Windows Mobile 5.0 and 2003 for Pocket PC; Windows Mobile 6.0 / 6.1 Classic and Professional	TCP/IP Port: 10000 RPB Port: 5552 (ViewLog Server)	Video Settings / GViewV2 Supported
<b>MSView V2</b>	Windows Mobile 5.0 and 2003 for Smartphone	TCP/IP Port: 10000 RPB Port: 5552 (ViewLog Server)	Video Settings / 3GPP, MSViewV2, SSVIEWV3 Supported
<b>MSView V3</b>	Windows Mobile 6.0 / 6.1 Standard and Professional	TCP/IP Port: 10000 RPB Port: 5552 (ViewLog Server)	Video Settings / 3GPP, MSViewV2, SSVIEWV3 Supported
<b>SSView V3</b>	Nokia S60 2nd Edition and 3rd Edition for Smartphone	TCP/IP Port: 10000 RPB Port: 5552 (ViewLog Server)	Video Settings / 3GPP, MSViewV2, SSVIEWV3 Supported
<b>3GPP</b>	Mobile phones with players supporting RTSP	TCP/IP Port: 8554 UDP Port: 17300-17319	Video Settings / 3GPP, MSViewV2, SSVIEWV3 Supported

Chart 1

---

**Note:**

1. For the 3G-enabled mobile phone, you can receive live video from the GV-Video Server without installing any GV mobile applications.
  2. To receive the live video from the GV-Video Server, enter the TCP/IP port on your mobile phone. To play video back, enable ViewLog Server on the GV-Video Server and enter the RPB Port on your mobile phone.
-

## 10.1 PDA

GView V2 is a remote view application for Pocket PC device. It can run on the PDA with Windows Mobile operating system. For the supported operating system version, see Chart 1.

When GView V2 detects the big screen panel of the mobile phone, images from the GV-Video Server will be horizontally rotated for a better view. Resolution is set to be CIF by default.

### 10.1.1 Installing GView V2

GView V2 should be installed on a PDA device with Microsoft Windows Mobile operating system.

1. Download and install **Microsoft PDA Viewer V2** from [http://www.geovision.com.tw/english/5\\_3.asp](http://www.geovision.com.tw/english/5_3.asp) to the computer.
2. Follow the on-screen instructions to complete the installation. The default installation directory is **C:\Microsoft PDA Viewer V2**.
3. Through the synchronization program such as **ActiveSync**, install **GViewV2.exe** from the installation directory to your PDA. Consult your PDA user's manual for how to install a program to the PDA.

### 10.1.2 Activating the GView Function

To allow remote access to the GV-Video Server, you must select **3GPP**, **Msview V2**, **Msview V3**, **Ssview V3** and **GView V2 Supported** to be the connection type in the Connection Template field on the Video Settings page. See "Connection Template" in *4.1.2 Video Settings* for details.

### 10.1.3 Connecting to GV-Video Server

Once GView V2 is installed on your PDA, you can use it to monitor your GV-Video Server. Make sure your PDA has wireless LAN adapter properly in place with access to the Internet.

1. Execute **GView V2** on your PDA.

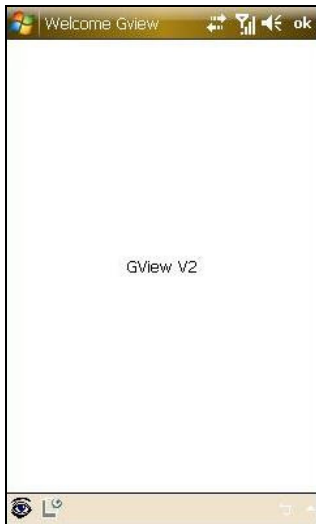

Figure 10-1

2. Click the  button located at the lower left corner. The login screen appears.

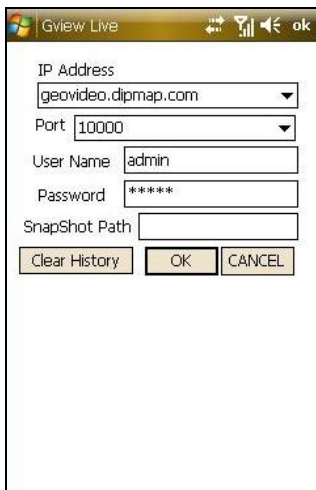



Figure 10-2

3. Enter the IP address of your GV-Video Server, port value (default value is 10000), a username and a password. Then click **OK**.
4. Once the connection is established, the live image will appear.

## 10.1.4 Playing Back the Recordings from GV-Video Server

To play back the recordings from the GV-Video Server, follow these steps:

1. Enable the **ViewLog Server** on GV-Video Server. Keep the connection port to be 5552 or modify it if necessary. See 4.3.6 *ViewLog Server* for details.
2. Execute **GView V2** in your PDA.
3. Click the  button located at the lower left corner (Figure 10-1). The login screen appears.

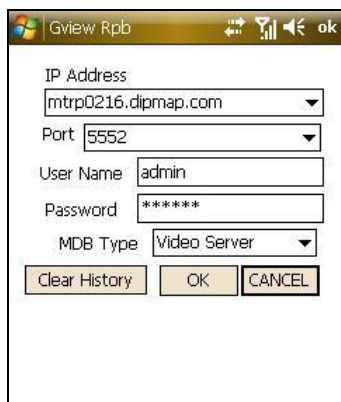

*Figure 10-3*

4. Enter the IP address of your GV-Video Server, port value (default value is 5552), a username and a password. Then click **OK** to connect.
5. Select the desired video recording from the event list for playback.

### 10.1.5 Other Functions

In addition to live view and playback, GView V2 offers these functions: viewing / controlling I/O devices, PTZ control, adjusting image quality, and starting / stopping recording.

On the live view screen, click the buttons on the toolbar to have the desired functions.

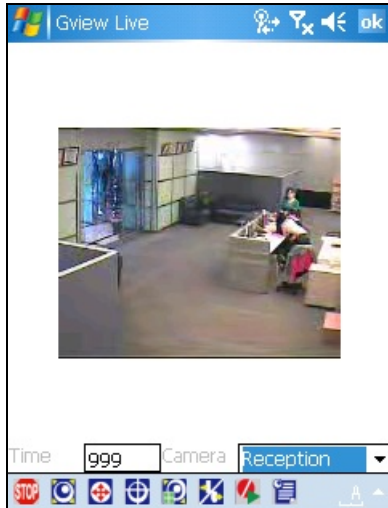

Figure 10-4

Button	Description
	Click it to stop the connection.
	Click it for Focus-in / Focus-out and Zoom-in / Zoom-out control. This is only available when the camera supports PTZ functions.
	Click it to move the camera to different directions. This is only available when the camera supports PTZ functions.
	Click it to move the camera to the preset positions. This is only available when the camera supports PTZ functions.
	Click it to adjust the image quality.
	Click it to access the connected I/O devices.
	Click it to start or stop recording.
	Click it to display the camera status.
Time <input type="text" value="999"/>	The supervisor is given the highest priority to control the PTZ camera and won't be restrained by 60-second time limit. When the supervisor logs in, the Timer shows 999.
Camera <input type="text" value="Reception"/>	Use this drop-down list to switch cameras.

## Accessing I/O Devices

To access the connected I/O devices, use the drop-down list to select the desired camera and click the  button. The I/O module button appears on the toolbar.



Figure 10-5

The numbers on the toolbar indicate the connected module. Click the desired number to access its I/O devices. The I/O control buttons appear on the toolbar.



Figure 10-6

Button	Description
<b>I</b>	Click it to view the log of input triggers.
<b>O</b>	Click it to display and force the connected output devices.

### Viewing Input-Triggered Events

All input triggers are logged on the Alarm list. Click the “**I**” button (Figure 10-6) to view the list of trigger events.

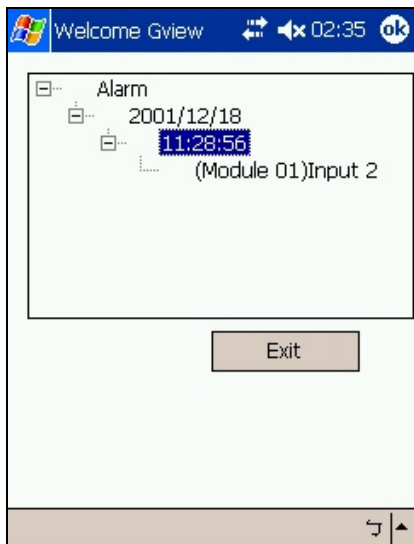

Figure 10-7

### Forcing Outputs

To force any connected output devices, click the “**O**” button (Figure 10-6) and click the desired number. The numbers on the toolbar indicate the connected output devices.



Figure 10-8

## Controlling PTZ Cameras

To control the PTZ camera, use the drop-down list to select the desired camera, and click the  button on the live view screen (Figure 10-4).

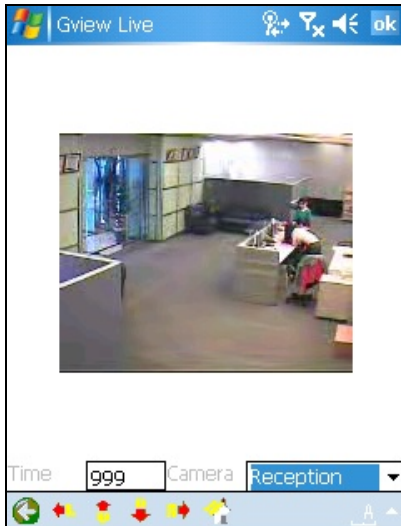





Figure 10-9

Button	Description
	Click it to return to the previous page.
	Use these buttons to move the PTZ camera to the left, up, down and right
	Click it to return to home.



### Viewing Camera Status

To view the camera status, click the  button on the live view screen (Figure 10-4).

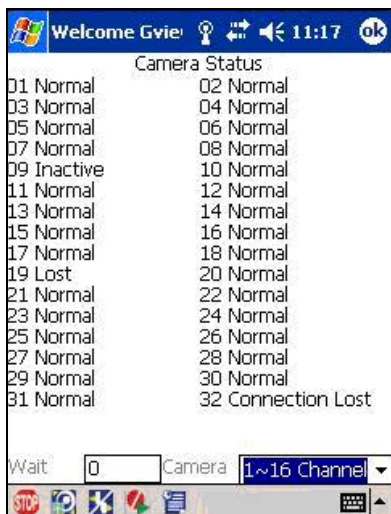

Figure 10-10

This screen displays the status of camera activity. Three messages indicate the current camera status.

Message	Description
<b>Normal</b>	The camera is turned on and not recording.
<b>Inactive</b>	The camera is turned off.
<b>Recording</b>	The camera is recording.

## 10.2 Windows Smartphone

With the MSView application, you can monitor your GV-Video Server remotely through a Windows-based smartphone. For the supported operating system version, see Chart 1.

### 10.2.1 Installing MSView V2 / V3

1. Download and install **Microsoft Smartphone Viewer V2** or **Microsoft Smartphone Viewer V3** from [http://www.geovision.com.tw/english/5\\_3.asp](http://www.geovision.com.tw/english/5_3.asp) to the computer.
2. Follow the on-screen instructions to complete the installation. The default installation directory is **C:\SmartPhone Viewer V2** or **C:\SmartPhone Viewer V3**.
3. Through the synchronization program such as **ActiveSync**, install **MsviewV2.exe** or **MsviewV3.exe** from the installation directory to your smartphone. Consult your smartphone user's manual for how to install a program to the smartphone.

### 10.2.2 Activating the MSView V2 / V3 Function

To allow remote access to the GV-Video Server, you must select **3GPP**, **MSViewV2**, **SSViewV3 Supported** to be the connection type in the Connection Template field on the Video Settings page. For details see "Connection Template" in *4.1.2 Video Settings*.

### 10.2.3 Connecting to GV-Video Server

The following operations may vary slightly for different modules.

1. Execute **MSViewV2.exe** or **MSViewV3.exe** on your smartphone.

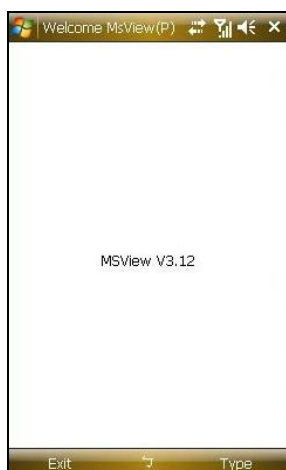

Figure 10-11

2. Click **Type** and then **Live**.

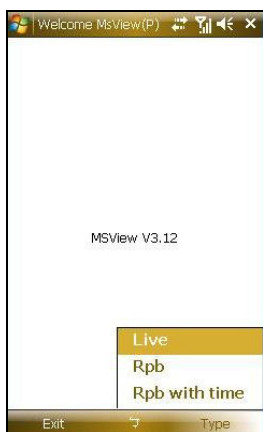

Figure 10-12

3. On the login screen, enter the IP address of your GV-Video Server, port value (default value is 10000), a username and a password. Then click **Control** and select **Connect**.

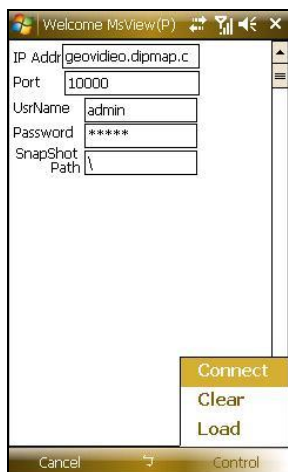

Figure 10-13

4. Once the connection is established, the live image will appear. You can use the scroll key on your smartphone to navigate camera channels.



Figure 10-14

## 10.2.4 Playing Back the Recordings from GV-Video Server

To play back the recordings from the GV-Video Server, follow these steps:

1. Enable the **ViewLog Server** on GV-Video Server. Keep the connection port to be 5552 or modify it if necessary. See 4.3.6 *ViewLog Server* for details.
2. Execute **MSView V2** or **MSView V3** in your smartphone.
3. Select **Type** and then **Rpb** (Figure 10-12). The login screen appears. If you want to search the recordings within a specific period of time for playback, select **Rpb with time**.

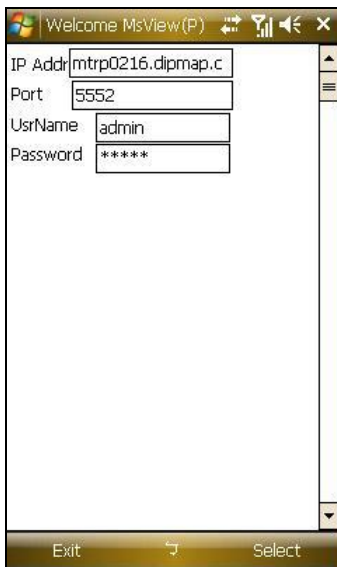

Figure 10-15

4. Enter the IP address of your GV-Video Server, port value (default value is 5552), a username and a password. Then click **Select** and click **GV Video Server** to start the connection.
5. Select the desired video recording from the event list for playback.

## 10.2.5 Other Functions

In addition to live view, MSView V2 or MSView V3 offers these functions: zooming in/out a camera view, rotating images and controlling outputs. Select the **Control** option to have these features.

## 10.3 Symbian Smartphone

With the SView V3 application, it's also possible to monitor your GV-Video Server remotely through a Symbian-based smartphone. For the supported operating system version, see Chart 1.

### 10.3.1 Installing SView V3

To install SView Version 3 for Nokia S60 2nd and 3rd Edition:

1. Download and install **Symbian Smartphone Viewer V3** from [http://www.geovision.com.tw/english/5\\_3.asp](http://www.geovision.com.tw/english/5_3.asp) to the computer.
2. Follow the on-screen instructions to complete the installation. The default installation directory is **C:\Symbain SmartPhone Viewer V3**.
3. Make a note of the modification date of **SsviewV3\_2nd.sis** or **SsviewV3\_3rd.sis**. Right-click the file, select **Properties** and find the date listed in the Modified field.
4. Change the date settings on the smartphone first. Here we use Nokia E61 as the example to illustrate the steps.
  - A. On the main menu of the smartphone, select **Tools Option ▶ App.manager ▶ Options ▶ Open ▶ App.downloads ▶ Options ▶ Settings ▶ Online certif..check**, and then set **Online certif..check** to be **Off**.
  - B. Return to the main menu, select **Tools ▶ Options ▶ Open ▶ Settings ▶ Options ▶ Open ▶ Date and time ▶ Options ▶ Open**, and then reset the date to be any within a year from the modification date of the application in the Date field. For example, if the modification date of **SsviewV3\_3rd.sis** is January 30, 2007, you can reset the date in the Date field to be any between January 30, 2007 and January 29, 2008.
5. Begin the installation of SView V3 on your smartphone. If your smartphone is of S60 2nd Edition, install **SsviewV3\_2nd.sis** from the installation directory to the smartphone. If your smartphone is of S60 3rd Edition, install **SsviewV3\_3rd.sis**. Consult your smartphone user's manual for how to install a program to the smartphone.
6. Follow Step 5 to change the date back to today's date.

### 10.3.2 Activating the SSView V3 Function

To allow remote access to the GV-Video Server, you must select **3GPP**, **MSViewV2**, **SSViewV3 Supported** to be the connection type in the Connection Template field on the Video Settings page. For details, see “Connection Template” in 4.1.2 *Video Settings*.

### 10.3.3 Connecting to GV-Video Server

The following operations may vary slightly for different modules.

1. Execute **SSView** on your smartphone.
2. When the message *SSView V3* appears, select **Options**, and select **Live Connect**. The login screen appears.



Figure 10-16

3. Enter the IP address of your GV-Video Server, port value (default value is 10000), a username and a password. Then click **Options** and select **Connect**.
4. Once the connection is established, the live image will appear.

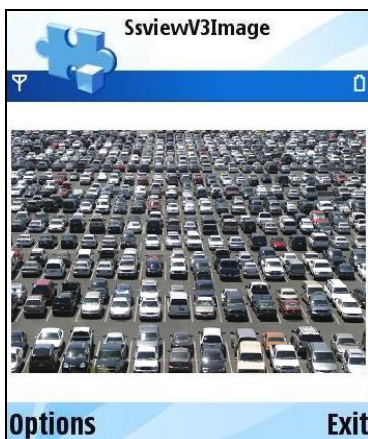

Figure 10-17

### 10.3.4 Quick Connection

The IP addresses of connected servers can be stored for quick connection in the future. Press the [<] and [>] buttons on the mobile device to select the desired server for connection.

### 10.3.5 Playing Back the Recordings from GV-Video Server

To play back the recordings from the GV-Video Server, follow these steps:

1. Enable the ViewLog Server on GV-Video Server. Keep the connection port to be 5552 or modify it if necessary. See 4.3.6 ViewLog Server for details.
2. Execute **SSView** on your smartphone.
3. When the message **SSView V3** appears, click **Options**, and then select **Rpb**. The login screen appears. If you want to search the recordings within a specific period of time for playback, select **Rpb With Time**.

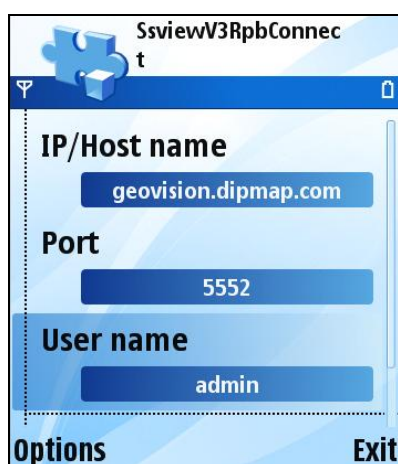

Figure 10-18

4. Enter the IP address of your GV-Video Server, port value (default value is 5552), a username and a password. Then click **Options** and select **Video Server**.
5. Select the desired video recording from the event list for playback.

### 10.3.6 Other Functions

In addition to live view, SSView offers these functions: changing camera channels, zooming in a camera view, rotating images and controlling outputs. Select **Options** to have these features.

## 10.4 3G Mobile Phone

Without installing any GV applications, you can use a 3G mobile phone to access GV-Video Server directly.

### 10.4.1 Activating the 3G Mobile Phone Function

To allow remote access to the GV-Video Server, first you must select **3GPP**, **MSViewV2**, **SSViewV3 Supported** to be the connection type in the Connection Template field on the Video Setting page, and then enable the 3GPP Server on GV-Video Server. See *4.1.1 Video Settings* and *4.3.7 3GPP* for details.

### 10.4.2 Connecting to the GV-Video Server

1. Open the Internet browser in the mobile phone, enter the IP address of your GV-Video Server, a user name and a password. Then click **Apply** to connect.



Figure 10-19

2. After the connection is established, an image similar to this example appears.

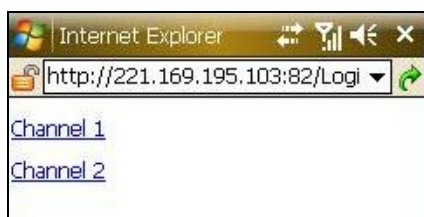

Figure 10-20



3. Select the desired channel. Its live image will appear.



Figure 10-21

---

**Note:** Currently the 3GPP application does not support remote playback and I/O control.

---

# Specifications

## Video

Model		GV-VS02	GV-VS02A	GV-VS04A	GV-VS12
Video Standard		NTSC, PAL			
Video Input		2 channels		4 channels	2 channels
Compression		MPEG4			H.264, MPEG4 MJPEG
Frame Rate (at Full D1 resolution)	NTSC	30 fps per channel 60 fps in total for 2 channels, 120 fps in total for 4 channels			
	PAL	25 fps per channel; 50 fps in total for 2 channels, 100 fps in total for 4 channels			
Resolution		Full D1, Half D1, CIF, QCIF			
Video Streaming		Configurable frame rate and bandwidth, Constant and variable bitrate			
Video Adjustment		Brightness, Contrast, Hue, Saturation, Image Quality, Image Size, Bitrate, GOP (Group of Picture) size			

## Audio

Model	GV-VS02	GV-VS02A	GV-VS04A	GV-VS12
Audio Input	2 channels		4 channels	2 channels
Compression	G.723			G.711

## Management

Event Management	Trigger	Schedule, Sensor Input, Motion Detection
	Action	Storing video (AVI format), Email with captured images, Captured images uploaded over FTP, Monitoring by Center V2, VSM and GV-GIS, Relay outputs to control external devices
Firmware Upgrade		Remote upgrade by HTTP, Firmware upgrade utility included in the Software DVD
Storage		Mass storage through USB (optional)
Client PC Requirements		Microsoft IE 6.x or above running on Windows 2000/XP/2003/Vista
Security		IP address filtering

### Network

<b>Interface</b>	10/100 Base-T Ethernet, 802.11b/g, 802.11n Wireless LAN (optional)
<b>Protocol</b>	HTTP, TCP, UDP, SMTP, FTP, DHCP, NTP, UPnP, DynDNS, Multicast

### Power over Ethernet

<b>PoE Standard</b>	IEEE 802.3af Power over Ethernet / PSE
<b>PoE Power Supply Type</b>	End-Span
<b>PoE Power Output</b>	Per Port 48V DC, 350mA. Max. 15.4 watts

### Connector

Model	GV-VS02	GV-VS02A	GV-VS04A	GV-VS12
<b>Video Input</b>	2 BNC ports		4 BNC ports	2 BNC ports
<b>Audio Input</b>	2 RCA ports		2 stereo phone jack to 4 RCA ports	2 RCA ports
<b>Audio Output</b>	1 RCA port			
<b>Terminal Block</b>	4 digital inputs, 4 relay outputs, RS±485, 1 Wiegand interface, 1 UART interface			RS-232 interface for GPS
<b>RJ-45 Connector</b>	N/A			2 digital inputs, 2 relay outputs, RS±485
<b>Ethernet</b>	RJ-45, 10/100 Mbps			
<b>USB 2.0</b>	2 ports			
<b>Power</b>	<b>Power Jack</b>	1 DC-In power jack 1 DC-Out power jack		1 DC-In power jack
	<b>Input</b>	100-240V, 1.2A, 50-60 mhz		
	<b>Output</b>	12V, 3A (60W Max.)		

### Alarm

Model	GV-VS02	GV-VS02A	GV-VS04A	GV-VS12
<b>Sensor Input</b>	4 inputs			2 inputs
<b>Alarm Output</b>	4 outputs			2 outputs

## Environment

Model	GV-VS02	GV-VS02A	GV-VS04A	GV-VS12
Operation Temp.	-10 ~ 50 °C / 14 ~ 122 °F	-20 ~ 55 °C / -4 ~ 131 °F		
Humidity	0 ~ 85% RH (non-condensing)			

## Physical

Model	GV-VS02	GV-VS02A	GV-VS04A	GV-VS12
Dimensions (L x W x H)	174 x 145 x 40 mm / 6.85 x 5.71 x 1.57 in			123 x 106 x 25 mm / 4.84 x 4.17 x 0.98 in
Weight	0.75 kg / 1.65 lbs	0.74 kg / 1.63 lbs	0.73 kg / 1.61 lbs	0.345 kg / 0.76 lbs

## Default Port Value

HTTP Port	80
Streaming Port	10000
E-Mail Server	25
FTP Server	21
Center V2	5551
VSM	5609
GV-GIS	3356
ViewLog Server	5552
RTSP/TCP Port	8554
RTP/UDP Port	17300-17319

# Appendix

## A. Supported Wireless LAN USB Adaptor

The models supported these adaptors include **GV-VS02** (Firmware Version 1.46 or later), **GV-VS02A**, **GV-VS04A** and **GV-VS12**.

Vendor	Model
D-Link	DWL-G122 C1 version
Edimax	EW-7318Ug
Linksys	WUSB54GC
<b>Note:</b> Linksys WUSB54GC ver. 3 is not supported.	

The model supported these adaptors includes **GV-VS02A** (Firmware Version 1.01 or later), **GV-VS04A** and **GV-VS12**.

Vendor	Model
D-Link	DWA-140 (H/W version B1)
Edimax	EW-7718Un
Linksys	WUSB600

## B. Supported Mobile Broadband Device

The models supported these devices include **GV-VS02** (Firmware Version 1.46 or later), **GV-VS02A**, **GV-VS04A** and **GV-VS12**.

Vendor	Model
Huawei	E220 USB Modem (HSDPA/UMTS/EDGE/GPRS/GSM)
Verizon	Wireless USB727 Modem (EVDO)

The models supported this device include **GV-VS02A** (Firmware Version 1.01 or later), **GV-VS04A** and **GV-VS12**.

Vendor	Model
Huawei	E169
Huawei	E1750
Novatel	MC950D

## C. Settings for Internet Explorer 8

If you use Internet Explorer 8, it is required to complete the following setting.

1. Set the Security to **Medium-high (default)**.
2. Enable **Allow previously unused ActiveX controls to run without prompt**.
3. Disable **Only allow approved domains to use ActiveX without prompt**.

