

## CE-L22 21.5" HDMI LCD Monitor



### INFO:

- 1920 x 1080 Resolution
- 16:9 Aspect Ratio
- 300 nit Brightness
- 1000:1 Contrast Ratio
- 1 VGA Input
- 1 HDMI Input (HDMI Cable Included)
- Plastic Bezel
- VESA 100
- DC12V (Power Supply Included)
- UL Listed

### DIMENSIONS:

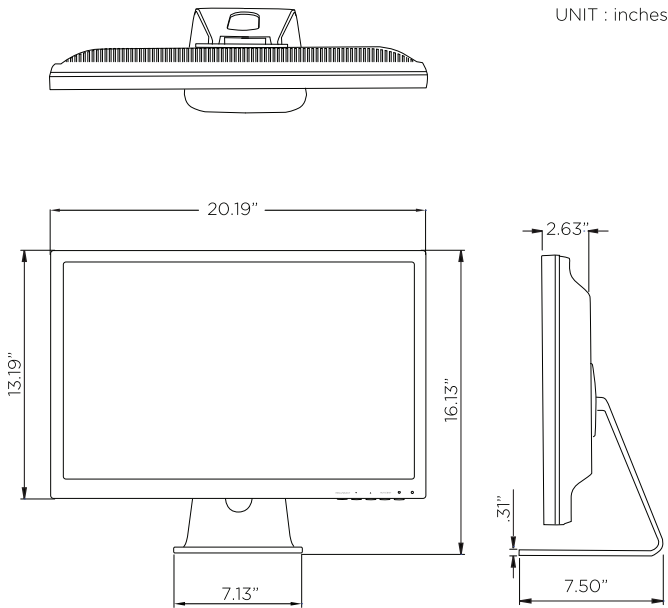

### SPECIFICATIONS:

Display	21.5" TFT LCD
Resolution	1920 x 1080
Control	OSD (On Screen Display) Control
Aspect Ratio	16:9
Display Colors	16.7M
Brightness	300 nit
Contrast Ratio	1000:1
Viewing Angle (H x V)	160° x 160°
Response Time	5ms
In / Out Impedance	75Ω /Auto Terminating Output
Mounting	VESA 100 / Stand Mount
Video Inputs / Outputs	1 VGA Input 1 HDMI
Audio Inputs / Outputs	n/a
Power Consumption	36 Watts
Power Requirement	DC 12V/5A (Output) AC 100V - 240V, 50/60 Hz (Input)
Operating Temperature	32°F - 122°F / 0°C - 50°C
Dimensions (W x H x D) *on stand	20.19" x 16.13" x 7.50" 512.826mm x 409.702mm x 190.5mm
Weight	12.6 lbs / 5.715kg

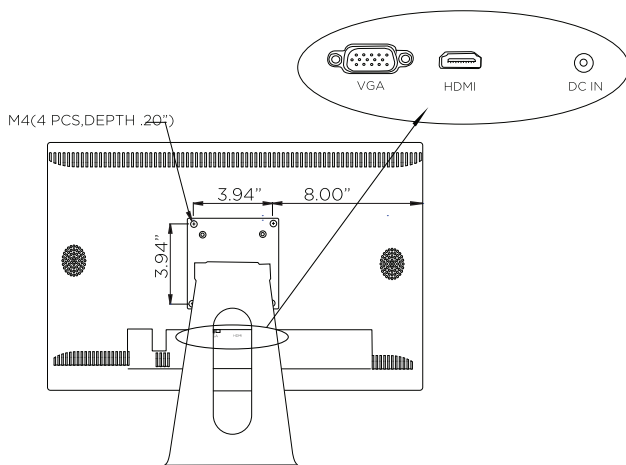

### CERTIFICATIONS:

