

# FlexScan® EV3237

## Dimension Drawing

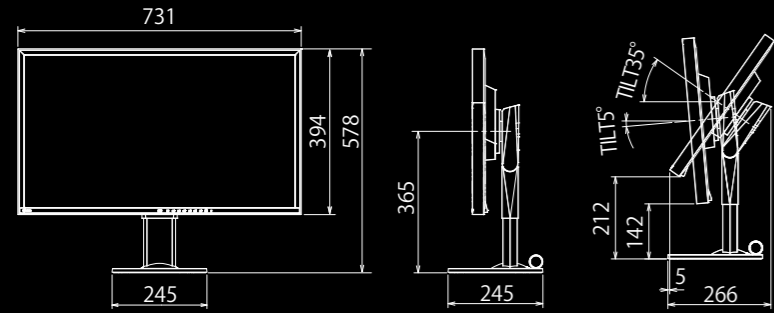

## Specifications

Model Variations	With FlexStand, Without Stand	
Cabinet Colors	Gray, Black	
Panel	Type	IPS
	Backlight	LED
	Size	31.5" / 80 cm (799 mm diagonal)
	Native Resolution	3840 x 2160 (16:9 aspect ratio)
	Viewable Image Size (H x V)	696.9 x 392.0 mm
	Pixel Pitch	0.1815 x 0.1815 mm
	Display Colors	16.77 million
	Viewing Angles (H / V, typical)	178°, 178°
	Brightness (typical)	300 cd/m <sup>2</sup>
	Contrast Ratio (typical)	1000:1
	Response Time (typical)	5 ms (Gray-to-gray)
Video Signals	Input Terminals	DisplayPort 1.2 x 2 (with HDCP 1.x), DVI-D 24 pin x1 (with HDCP 1.x), HDMI x 1 (with HDCP 1.x)
	Digital Scanning Frequency (H / V)	31 - 134 kHz, 29 - 31 Hz and 59 - 61 Hz
USB	Function	1 port for up stream 3-port USB hub (including 1 USB Battery charge port)
	Standard	USB 3.0, USB BC 1.2
Audio	Speakers	1.0 W +1.0 W
	Input Terminals	3.5 mm stereo jack
	Output Terminals	3.5 mm headphone jack
	Sound Adjustment	Volume, Power Save, Source (DisplayPort, HDMI)
Power	Power Requirements	AC 100 - 120 V / 200 - 240 V, 50 / 60 Hz
	Maximum Power Consumption	105 W
	Typical Power Consumption	30 W
	Power Save Mode	Less than 0.5 W
	Power Management	Power Save (VESA DPM, DisplayPort Rev. 1.1a, and DVI DMPM), Off Timer
Features & Functions	Preset Modes	Color mode (Paper, Movie, sRGB, User1, User2)
	Auto EcoView	Yes
	EcoView Sense	Yes
	OSD Languages	English, German, French, Italian, Japanese, Simplified Chinese, Spanish, Swedish, Traditional Chinese
Physical Specifications	Dimensions (Landscape, W x H x D)	731 x 439 - 578 x 245 mm
	Dimensions (Without Stand, W x H x D)	731 x 428 x 59.5 mm
	Net Weight	10.6 kg
	Net Weight (Without Stand)	7.8 kg
	Height Adjustment Range	139 mm
	Tilt	35° Up, 5° Down
	Swivel	344°
	Hole Spacing (VESA Standard)	100 x 100 mm
Environmental Requirements	Operating Temperature	5 - 35 °C
	Operating Humidity (R.H., non condensing)	20 - 80 %
	Certifications & Standards	TCO Displays 6.0, EPEAT Gold (US), TUV/Ergonomics (including ISO9241-307), TUV/GS, RCM, CE, CB, cTUVus, FCC-B, Canadian ICES-003-B, TUV/S, VCCI-B, EPA Energy Star, RoHS, WEEE, China RoHS, CCC, GOST-R
	Supplied Accessories	AC power cord, signal cables (DisplayPort - DisplayPort), USB cable, EIZO LCD Utility Disk (PDF user's manual), setup guide
	Warranty	Five Years



# FlexScan® EV3237

31.5" (80 cm) LCD Monitor

**4K UHD**  
**3840 × 2160**

## EIZO Corporation

153 Shimokashiwano, Hakusan, Ishikawa 924-8566 Japan  
Phone +81-76-277-6792 Fax:+81-76-277-6793  
[www.eizo.com](http://www.eizo.com)

FlexScan and EIZO are registered trademarks of EIZO Corporation.  
Specifications are subject to change without notice.

Copyright © 2014 EIZO Corporation. All rights reserved.

# Eye pleasing, work achieving.

CAD, business, gaming, video – this 31.5-inch monitor does it all. With its 4K UHD resolution and 60 Hz refresh rate, the FlexScan EV3237 provides you with an exceptional experience no matter the application.



## Smooth, Print-like Quality on Screen

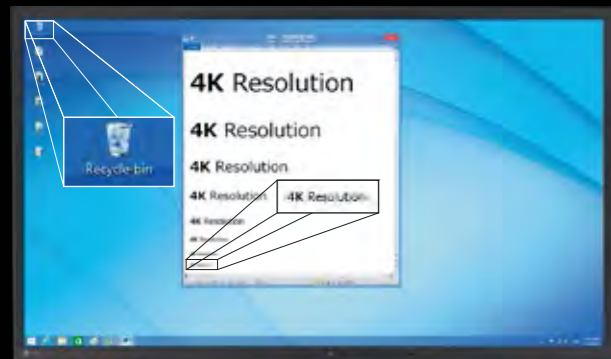

The FlexScan EV3237 packs more than 8 million pixels with over 140 dpi (dots per inch) for amazing results. Documents and images look smoother than ever with a 4K UHD screen, offering you the finest visual experience.

## Vivid and Consistent Color with IPS Panel



The IPS panel has 178° viewing angles so it exhibits minimal change in contrast and hue when viewed from off center. This makes it ideal for viewing a variety of content from any angle and also allows more than one person to view the screen clearly.

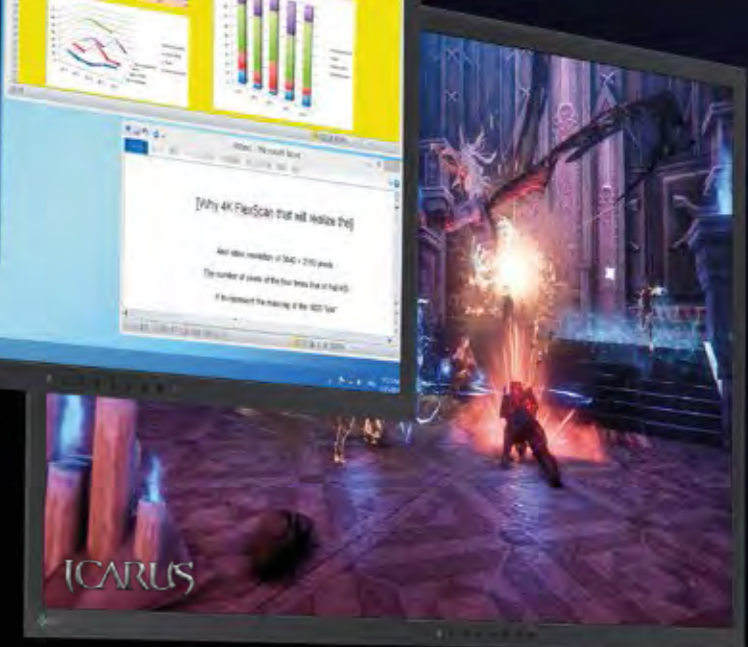

WeMade Entertainment Corp. / Wemade Online Co.,Ltd.

## Work Efficiently with a Large Screen

Increase your work efficiency by displaying more on screen at once without needing to change windows or scroll excessively. View 4K photos and videos in full screen to truly see the difference with the FlexScan EV3237's 31.5-inch screen.

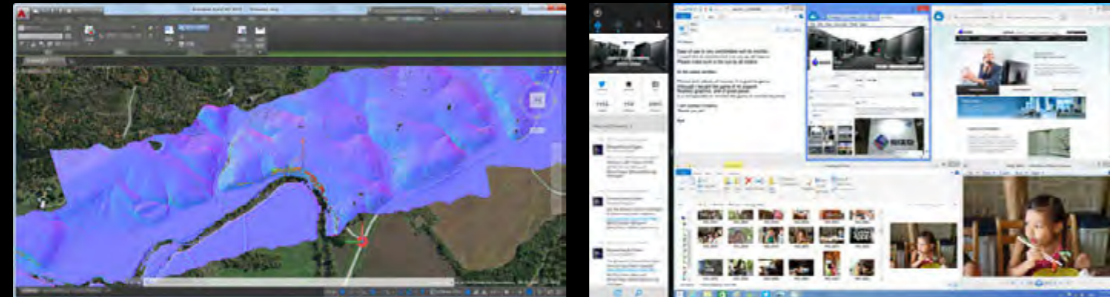

©Autodesk AutoCAD 2015

## Ergonomics – Visual Comfort to Increase Your Productivity

The FlexScan EV3237 includes a number of ergonomic features that help to reduce the eyestrain associated with viewing an LCD monitor for extended periods of time.



### Say Goodbye to Tired Eyes

A brightness sensor called Auto EcoView detects the fluctuations in the ambient brightness throughout the day and automatically adjusts the screen so it is neither too bright nor too dark. In addition, Paper Mode simulates the look of paper by reducing blue light, a cause of eye fatigue, to prevent eyestrain when reading documents.

### Flicker-Free for Reduced Eye Fatigue

The FlexScan EV3237 offers flicker-free viewing at all brightness levels. Now you can work without worrying about the eye fatigue caused by viewing a flickering screen for long periods.

### Non-Glare Panel

A non-glare panel reduces eye fatigue by dissipating reflective light that would otherwise make the screen difficult to view from different positions.

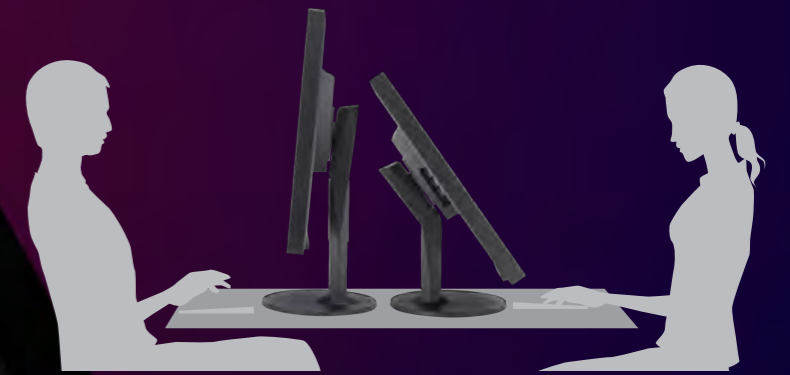

### Flexible Stand Positioning

Adjust the screen to the most comfortable angle for individual use or easily reposition it to show a colleague or client. The versatile stand offers height, tilt, and swivel adjustability for optimal comfort in any setting.

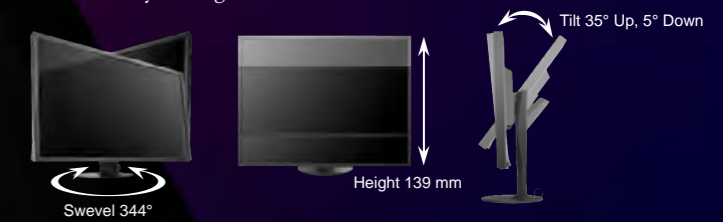

### Preset Modes for Optimum Viewing

Five preset modes ensure you always get the right setting for whatever application you are using. With the bundled ScreenManager Pro for LCD software, you can assign any of the monitor's preset modes to a particular application. Whenever you activate that application, the monitor will automatically switch to the assigned mode.

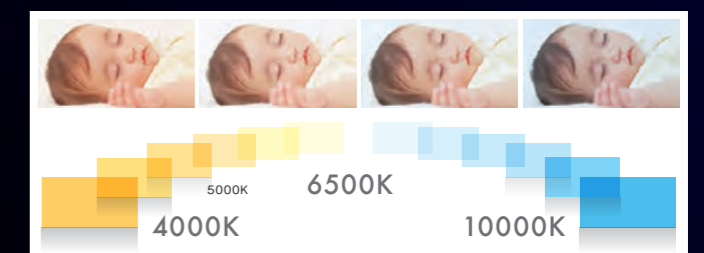

### Detailed Color Control

Hue, gain, saturation, and color temperature in 500 K increments from 4,000 – 10,000 K (and 9,300 K) are all user adjustable. An sRGB mode is also included for color matching with other applications and peripherals that also support this color space.

# Convenient Multitasking with Picture by Picture / Picture in Picture

## Picture *by* Picture

Picture by Picture (PbyP) is a feature that allows you to view data from multiple signal sources on a single screen simultaneously. Select from 5 different layouts easily accessible via a button on the front of the monitor. Picture by Picture can be used to run both Windows and Mac operating systems simultaneously or multiple applications in varying layouts and size to suit user preference.



## Picture *in* Picture

Picture in Picture (PinP) allows you to display a small separate screen from second signal source within the monitor. This allows you to effectively multitask such as viewing a video conference while working in other applications. The screen's size and position can be adjusted to your preference.

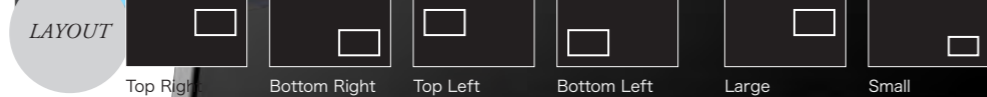
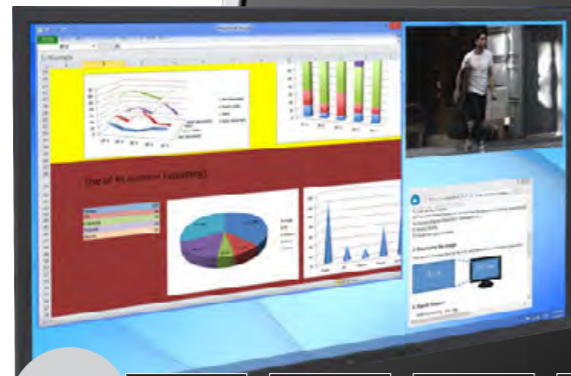

# A Feature Set Perfect for Home or Business

The FlexScan EV3237 includes a number of features and functions to suit a wide range of use.

## Multiple Inputs

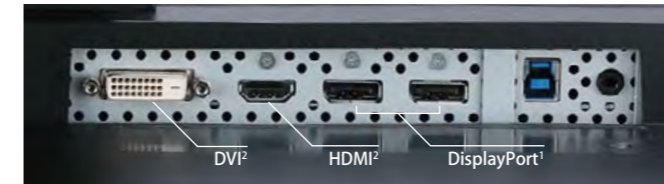

DisplayPort 1.2<sup>1</sup>, DVI<sup>2</sup> and HDMI<sup>2</sup> digital inputs are equipped for compatibility with multiple devices. Picture by Picture and Picture in Picture are also supported when using a dual-monitor setup.

<sup>1</sup>DisplayPort: 3840 x 2160 (60Hz, 16:9 aspect ratio)  
<sup>2</sup>DVI / HDMI: 3840 x 2160 (30Hz, 16:9 aspect ratio)

## USB 3.0 Battery Charger

The monitor comes equipped with three USB ports, one of which can be used to charge your smartphone, tablet, or other devices. Selecting "Charging Only" from the OSD menu speeds up the charging process.

## Smooth Color Gradations

The FlexScan EV3237 reproduces smooth images by taking an 8-bit signal (256 tones per RGB) and selecting the optimum color values from a 10-bit look-up table (1,021 tones). The optimized data is converted back to an 8-bit output signal for the smoothest gradations.

## Adjustable to Just 1.0 % of Maximum Brightness

In a dimly-lit work environment, a monitor with low brightness settings is more comfortable to use. With its LED backlight, the FlexScan EV3237 is adjustable to just 1.0 % of the maximum brightness, making it ideal for viewing in low ambient lighting conditions.

## Sharp Motion Images

An overdrive circuit accelerates gray-to-gray response time to just 5 ms to minimize ghosting and blurring in moving images so they always look clean and sharp.

## Speakers and Headphone Jack



Dual 1-watt speakers are installed without increasing bezel size. A headphone jack is also conveniently located on the side of the monitor.

## Easily Adjustable Settings

All of the monitor's settings are adjustable using the EIZO Monitor Configurator software. You can even save your settings as an xml file and apply them to another monitor via USB.

## Energy Savings

The FlexScan EV3237 offers a number of features for lowering power consumption. The Auto EcoView brightness sensor automatically lowers brightness according to ambient lighting and EcoView Optimizer 2 reduces backlight brightness and increases gain when viewing dark content. In addition, a presence sensor prompts the monitor to switch to power save mode when you are absent and then power on again when you return to save on energy while the monitor is not in use.

## Research and Development



To incorporate the latest technologies in our products we invest heavily in R&D. At our corporate headquarters in Japan we have a dedicated R&D center. Here, all the engineers who develop FlexScan products are in one location, allowing for improved efficiency and reduced development time.

## Quality Control

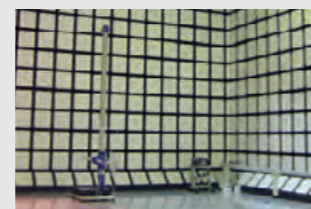

Safety and reliability are hallmarks of FlexScan monitors. We have our own anechoic chambers to confirm that our products comply with international regulations covering electromagnetic interference (EMI) and susceptibility. We also conduct longlife testing where our monitors are kept powered on for tens of thousands of hours and their image quality is regularly checked.

## Manufacturing



Our manufacturing combines manual and automated operations to ensure high quality products made as efficiently as possible. Manual operations are performed for assembly tasks that cannot be automated or for verifying image quality. Automated operations take advantage of robotic and CCD (charge coupled device) camera technologies to more efficiently perform mechanical tasks.

## 5 Year Warranty



As more desktop LCD monitor brands outsource development and production to third parties, we remain convinced that the best way to deliver the quality that our customers expect is to maintain our integrated approach. This gives us the confidence to back them up with the industry's only five-year manufacturer's warranty.