

# GV-IP Panoramic Cameras

## *User's Manual*



- GV-PBL8800
- GV-PDR8800

Before attempting to connect or operate this product, please read these instructions carefully and save this manual for future use.



© 2023 GeoVision, Inc. All rights reserved.

Under the copyright laws, this manual may not be copied, in whole or in part, without the written consent of GeoVision.

Every effort has been made to ensure that the information in this manual is accurate. GeoVision, Inc. makes no expressed or implied warranty of any kind and assumes no responsibility for errors or omissions. No liability is assumed for incidental or consequential damages arising from the use of the information or products contained herein. Features and specifications are subject to change without notice.

GeoVision, Inc.  
9F, No. 246, Sec. 1, Neihu Rd.,  
Neihu District, Taipei, Taiwan  
Tel: +886-2-8797-8377  
Fax: +886-2-8797-8335  
<http://www.geovision.com.tw>

Trademarks used in this manual: *GeoVision*, the *GeoVision* logo and *GV* series products are trademarks of GeoVision, Inc. *Windows* is the registered trademark of Microsoft Corporation.

September 2023

**Scan the following QR codes for product warranty and technical support policy:**



[Warranty]



[Technical Support Policy]

# Preface

Welcome to the *GV-IP Panoramic Cameras' User's Manual*.

The features described in the manual vary among camera models and versions. Some features may not be available in your camera.

This manual is designed for the following camera models:

Model	Model Number
Panoramic IR Fixed Bullet IP Camera	GV-PBL8800
Panoramic IR Fixed Rugged IP Dome	GV-PDR8800

# Table of Contents

<b>Preface</b> .....	<b>1</b>
<b>Chapter 1. Introduction</b> .....	<b>1</b>
Safety Instruction.....	1
<b>Chapter 2. Product Description</b> .....	<b>2</b>
2.1 Product Overview .....	2
2.2 Key Features .....	2
2.3 System Requirements.....	4
<b>Chapter 3. Configuration Flow</b> .....	<b>5</b>
<b>Chapter 4. Network Connection</b> .....	<b>7</b>
4.1 Setting the Camera over the LAN .....	7
4.1.1 Connect via a Switch or Router .....	7
4.2 Dynamic IP Connection.....	8
<b>Chapter 5. Accessing the Network Camera</b> .....	<b>9</b>
5.1 Assigning an IP Address .....	9
5.1.1 Assigning an IP Address Using GV-IP Device Utility .....	9
5.1.2 Assigning an IP Address via Browser.....	10
5.2 Accessing from the Web Browser .....	13
<b>Chapter 6. Live View</b> .....	<b>14</b>
6.1 Live Video .....	14
<b>Chapter 7. Playback</b> .....	<b>17</b>
<b>Chapter 8. Settings</b> .....	<b>21</b>
8.1 Media .....	21
8.1.1 Video.....	21
8.1.2 Image.....	25
8.2 Network.....	42
8.2.1 Basic.....	42
8.2.2 Advanced .....	52
8.3 Storage.....	66
8.3.1 Storage Management.....	66
8.3.2 Record Settings.....	67
8.3.3 Snapshot Settings .....	69
8.3.4 Explorer .....	71
8.4 Event.....	72
8.4.1 Basic Event.....	72
8.4.2 VCA Event .....	79
8.4.3 People Counting .....	101
8.4.4 Heat Map.....	129
8.5 System .....	135
8.5.1 System Setting .....	135
8.5.2 Security .....	137
8.5.3 Logs .....	143

**Appendix..... 146**  
**A. GV-Mount430..... 146**  
**B. GV-Mount923..... 148**

# Chapter 1. Introduction

## *Safety Instruction*

These instructions are intended to ensure that user can use the product correctly to avoid danger or property loss. The precaution measures are divided into “Warnings” and “Cautions”

**Warnings:** Serious injury or death may be caused if any of these warnings is neglected.

- This installation must be conducted by a qualified service person and should strictly comply with the electrical safety regulations of the local region
- To avoid risk of fire and electric shock, do keep the product away from rain and moisture before installed.
- Do not touch components such as heat sinks, power regulators, and processors, which may be hot
- Source with DC 12V or PoE
- Please make sure the plug is firmly inserted into the power socket
- When the product is installed on a wall or ceiling, the device should be firmly fixed
- If the product does not work properly, please contact your dealer. Never attempt to disassemble the camera by yourself

**Cautions:** Injury or equipment damage may be caused if any of these cautions are neglected.

- Make sure that the power supply voltage is correct before using the camera
- Do not store or install the device in extremely hot or cold temperatures, dusty or damp locations, and do not expose it to high electromagnetic radiation
- Only use components and parts recommended by manufacturer
- Do not drop the camera or subject it to physical shock
- To prevent heat accumulation, do not block air circulation around the camera
- Laser beams may damage image sensors. The surface of image sensors should not be exposed to where a laser beam equipment is used
- Use a blower to remove dust from the lens cover
- Use a soft, dry cloth to clean the surface of the camera. Stubborn stains can be removed using a soft cloth dampened with a small quantity of detergent solution, then wipe dry
- Do not use volatile solvents such as alcohol, benzene or thinners as they may damage the surface finishes
- Save the package to ensure availability of shipping containers for future transportation

# Chapter 2. Product Description

## 2.1 Product Overview

GeoVision provides a consistent range of cost-effective and reliable network cameras to fully meet your requirements. Based on embedded Linux operating system, GeoVision's panoramic IP camera series could be easily accessed and managed either locally or remotely with great reliability. With built-in high-performance DSP video processing modules, the cameras pride on low power consumption and high stability. They support state-of-the-art H.265/ H.264/ MJPEG video compression algorithm and industry-leading HD dual-stream technology to achieve the highest level of video image quality under the limited network resources. It is fully functional, supporting for flexible and comprehensive alarm linkage mechanism, day and night auto switch and privacy masking, etc.

In practical applications, GeoVision's IP cameras could either work independently in the LAN, or be networked to form a powerful safety monitoring system. It is widely used in fields such as finance, education, industrial production, civil defense, health care for security's sake.

## 2.2 Key Features

### System

- Built-in WEB server, support IE/ Firefox/ Chrome/ Safari browser
- Based on Linux OS with high reliability
- Support Plugin-Free mode
- Support activation and set-up of the security questions for cameras
- Support ONVIF Profile G & S & T
- Different privilege levels of users for flexible management
- Micro SD/SDHC/SDXC card local storage support, expand the edge storage

### Image

- 0.012 Lux Ultra Low Light
- Smart IR technology
- 8 MP Video Viewing Experience
- WDR Pro
- Support HLC
- Support BLC
- ICR filter with auto switch, true day/night
- Corridor Mode

## **Video**

- H.265/ H.264/ MJPEG video compression capability
- Support Primary Stream/ Secondary Stream/ Tertiary Stream
- Support Smart Stream by 10-level adjustable H.265+
- Bandwidth saved by Smart Stream with stable network connection
- Real-time video electronic amplification

## **Audio**

- G.711 audio compression capability

## **Network**

- UPnP protocol for the easy management of camera
- Support DDNS
- FTP upload, SMTP upload, SD card record and SIP phone

## **Advanced Function**

- Motion Detection, Privacy Masking, and ROI
- Support AI Video Content Analysis
- Support People Counting function
- Support Heat Map function

## **Hardware**

- Support PoE for power supply
- Built-in Microphone
- IK10 vandal-proof metal cover, and IP67-rated weather-proof housing



## 2.3 *System Requirements*

**Operating System:** Windows XP/Vista/7/8/10/11

**CPU:** 1.66GHz or higher

**RAM:** 1G or higher

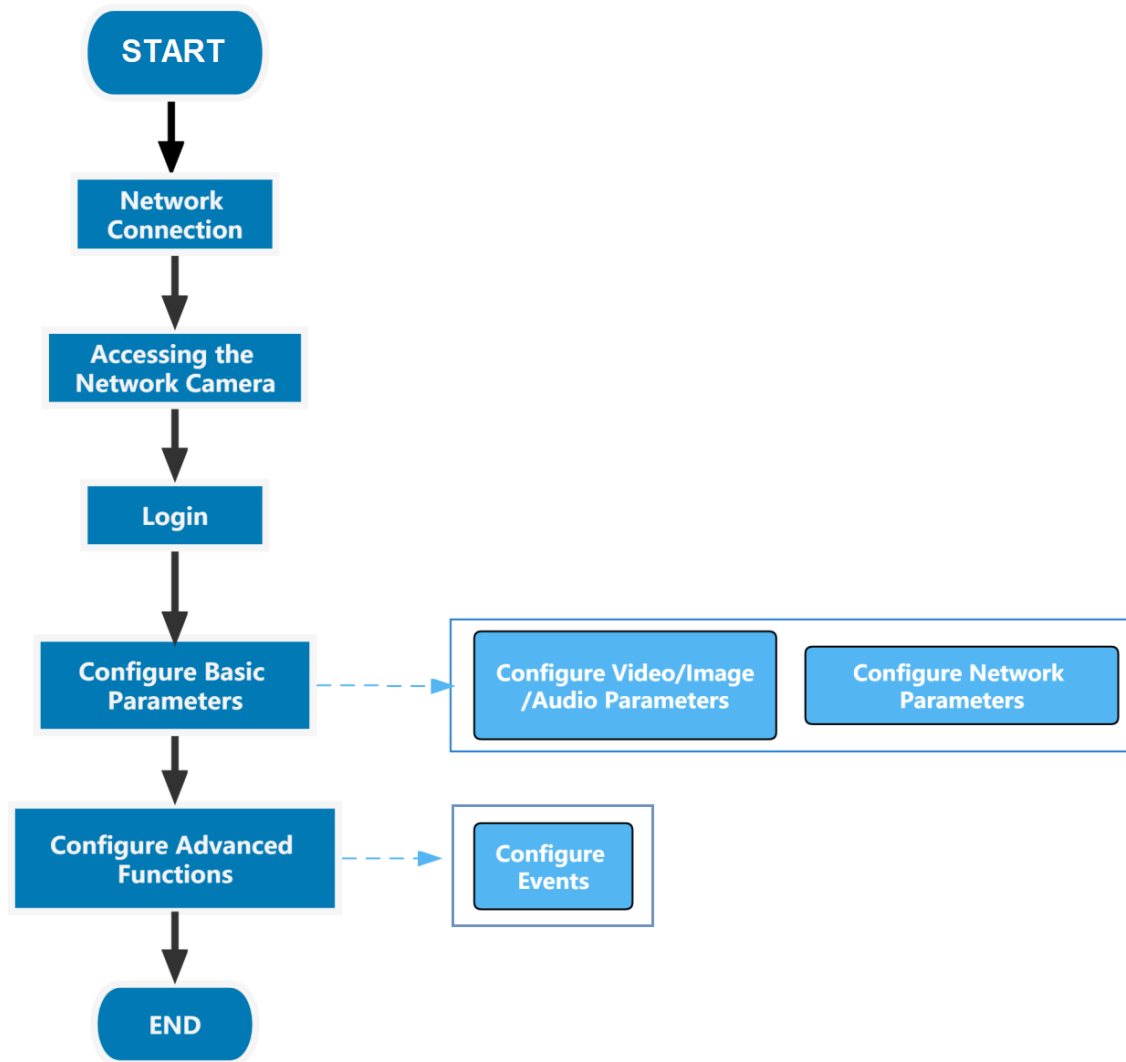
**Graphic memory:** 128MB or more

**Internet protocol:** TCP/IP (IPv4/IPv6)

**Web Browsers:** Internet Explorer 8.0 and above version, Mozilla Firefox, Google Chrome and Safari.

# Chapter 3. Configuration Flow

The configuration flow of cameras is shown in the following figure.



**Note:** The configuration must be based on the actual situation of different models.

More configuration details are shown in the following table.

**Table 1. Description of flow**

<b>Configuration</b>	<b>Description</b>	<b>Reference</b>
<b>Network Connection</b>	Connect the network camera. You can set the camera over the LAN or dynamic IP connection.	<a href="#">4.1 Setting the Camera over the LAN</a>
<b>Accessing the Network Camera</b>	Accessing from IP address, web browser and back-end software are available.	<a href="#">5.1 Assigning An IP Address</a>
<b>Configure Basic Parameters</b>	After logging in the camera, you can adjust the video/image/audio/network parameters as needed.	<a href="#">8.1.1 Video</a>
<b>Configure Advanced Functions</b>	Configure the advanced functions, such as VCA and people counting.	<a href="#">8.4.2 VCA Event</a>

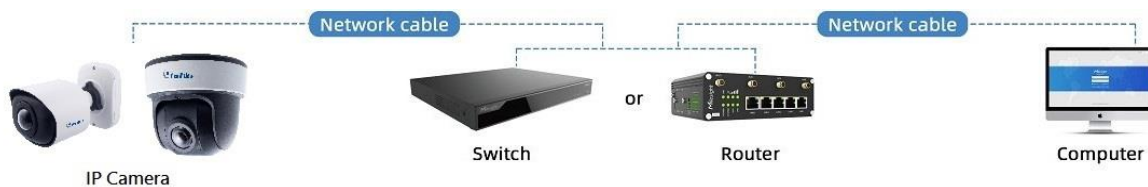
## Chapter 4. Network Connection

### 4.1 *Setting the Camera over the LAN*

Connecting the camera to a switch or a router is the most common connection method. The camera must be assigned an IP address that is compatible with its LAN.

#### 4.1.1 *Connect via a Switch or Router*

Refer to the following figure to set network camera over the LAN via the switch or router.



## 4.2 Dynamic IP Connection

**Step 1:** Connect the network camera to a router;

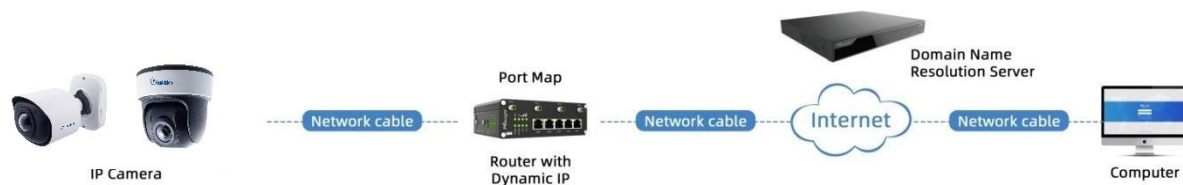
**Step 2:** On the camera, assign a LAN IP address, the Subnet mask and the Gateway;

**Step 3:** On the router, set port forwarding. E.g. 80, 8000 and 554 ports. The steps for port forwarding vary depending on different routers. Please look up the router's user manual for assistance with port forwarding.

**Step 4:** Apply a domain name from a domain name provider.

**Step 5:** Configure the DDNS settings in the setting interface of the router.

**Step 6:** Visit the camera via the domain name.



# Chapter 5. Accessing the Network Camera

## *5.1 Assigning an IP Address*

The Network Camera must be assigned an IP address to be accessible. The default IP address of the network camera is 192.168.0.10.

You can change the IP address of the camera via GV-IP Device Utility, via browser, or from the web browser. Please connect the camera in the same LAN of your computer.

### *5.1.1 Assigning an IP Address Using GV-IP Device Utility*

See *Chapter 5 Advanced Settings* [here](#) for assigning an IP address using GV-IP Device Utility.

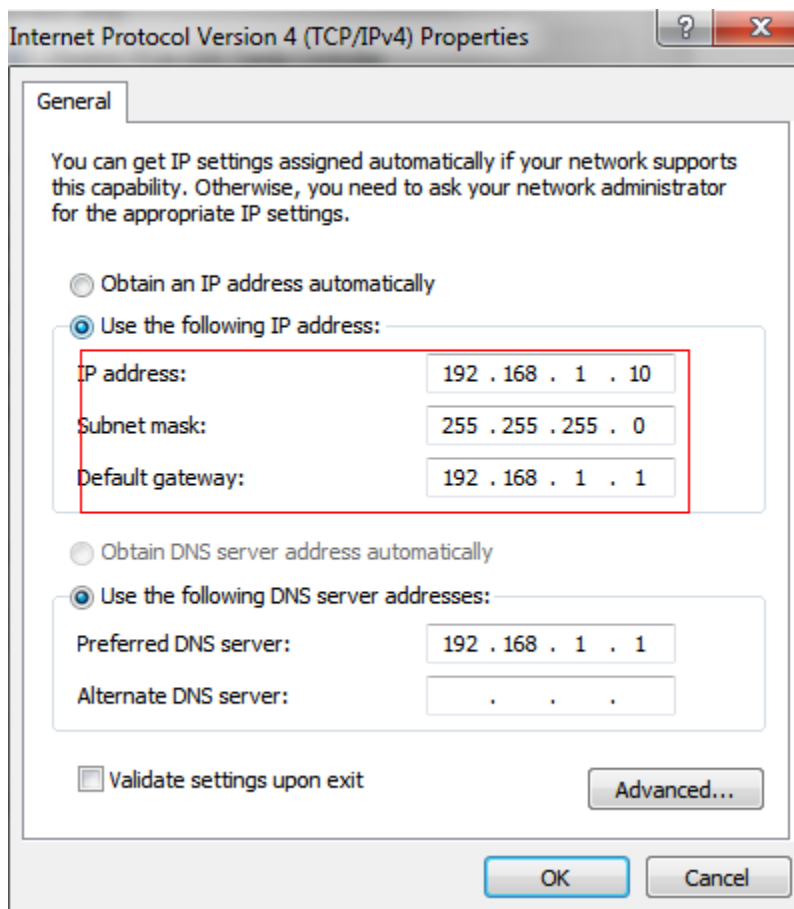
Note that this function is only applicable on GV-IP Device Utility V8.9.7.0 or later.

## 5.1.2 Assigning an IP Address via Browser

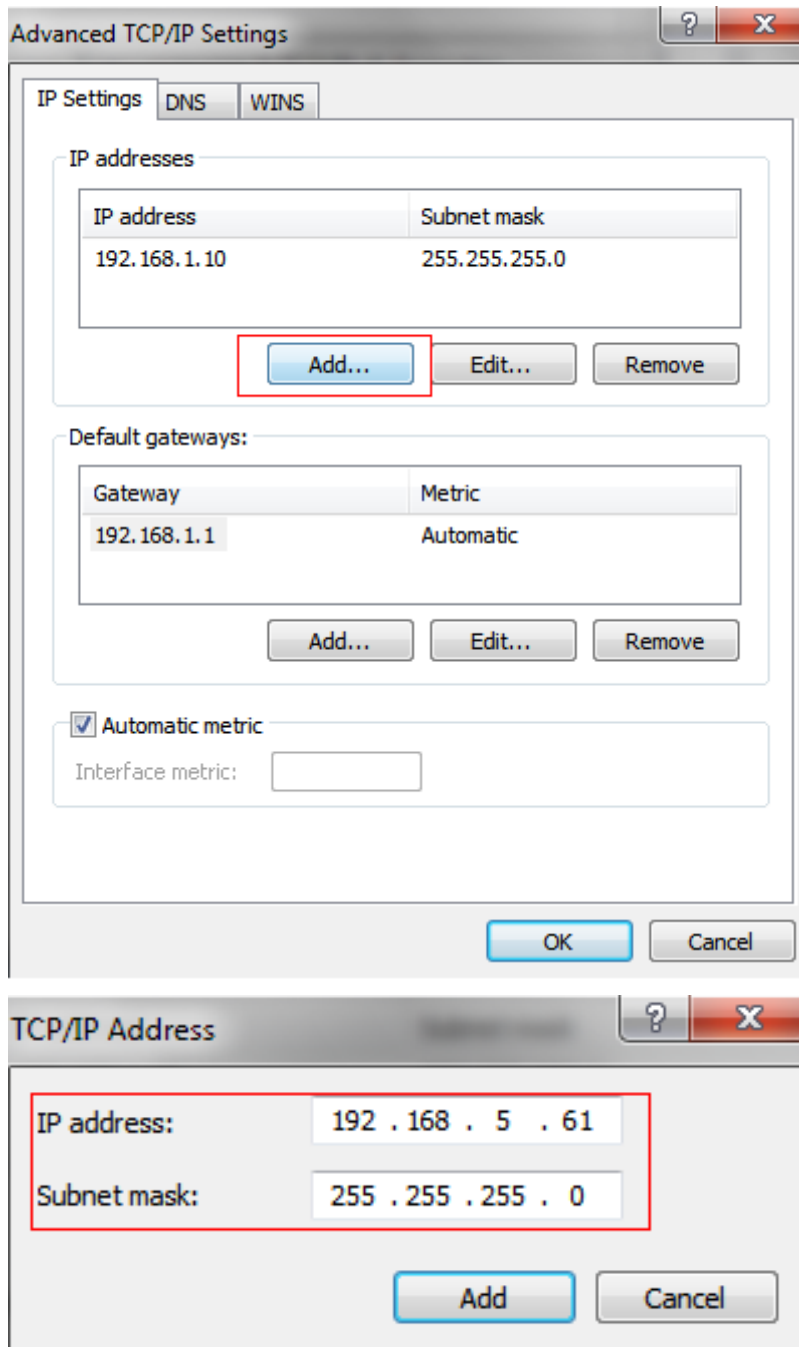
Follow the steps to change the IP address of the camera via browser:

**Step 1:** Change the IP address of computer to 192.168.0.10 segment, here are two ways as below:

- a. Start → Control Panel → Network and Internet Connection → Network Connection → Local Area Connection, and double click it;



b. Click “Advanced”, and then click “IP settings”--> “IP address”--> “Add”. In the pop-up window, enter an IP address that in the same segment with the camera (e.g. 192.168.0.60), but please note that this IP address shall not conflict with the IP address on the existing network);



**Step 2:** Start the browser. In the address bar, enter the default IP address of the camera: <http://192.168.0.10>

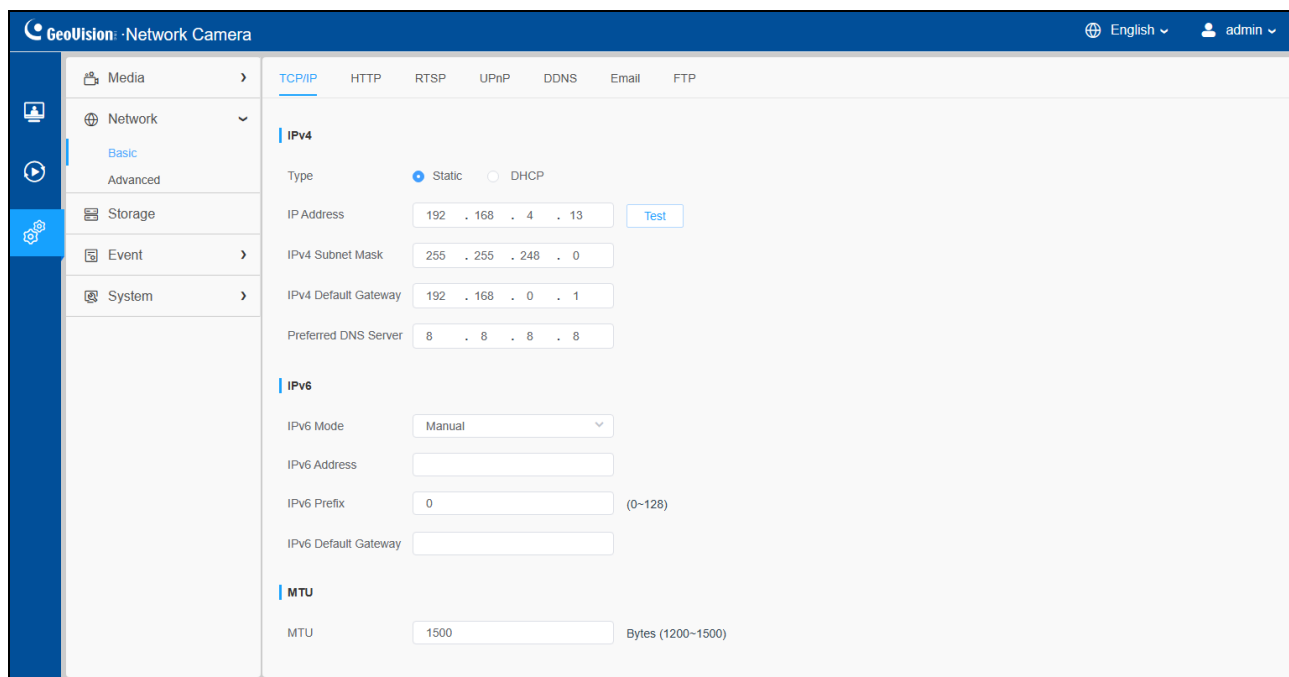


**Step 3:** You need to set the password first when using it for the first time. And you can also set three security questions for your device after activation. Then you can log in to the camera with the default user name (admin) and a custom password.

**Note:**

- Password must be 8 to 32 characters long, contain at least one number and one letter.
- You can click the “Forget Password?” on the login page to reset the password by answering three security questions when you forget the password, if you set the security questions in advance.

**Step 4:** After login, please select “Settings” → “Network” → “Basic” → “TCP/IP”. The Network Settings page appears (Shown as below);



**Step5:** Change the IP address or other network values. Then click “**Save**” button;

**Step6:** The change of default IP address is completed.

## *5.2 Accessing from the Web Browser*

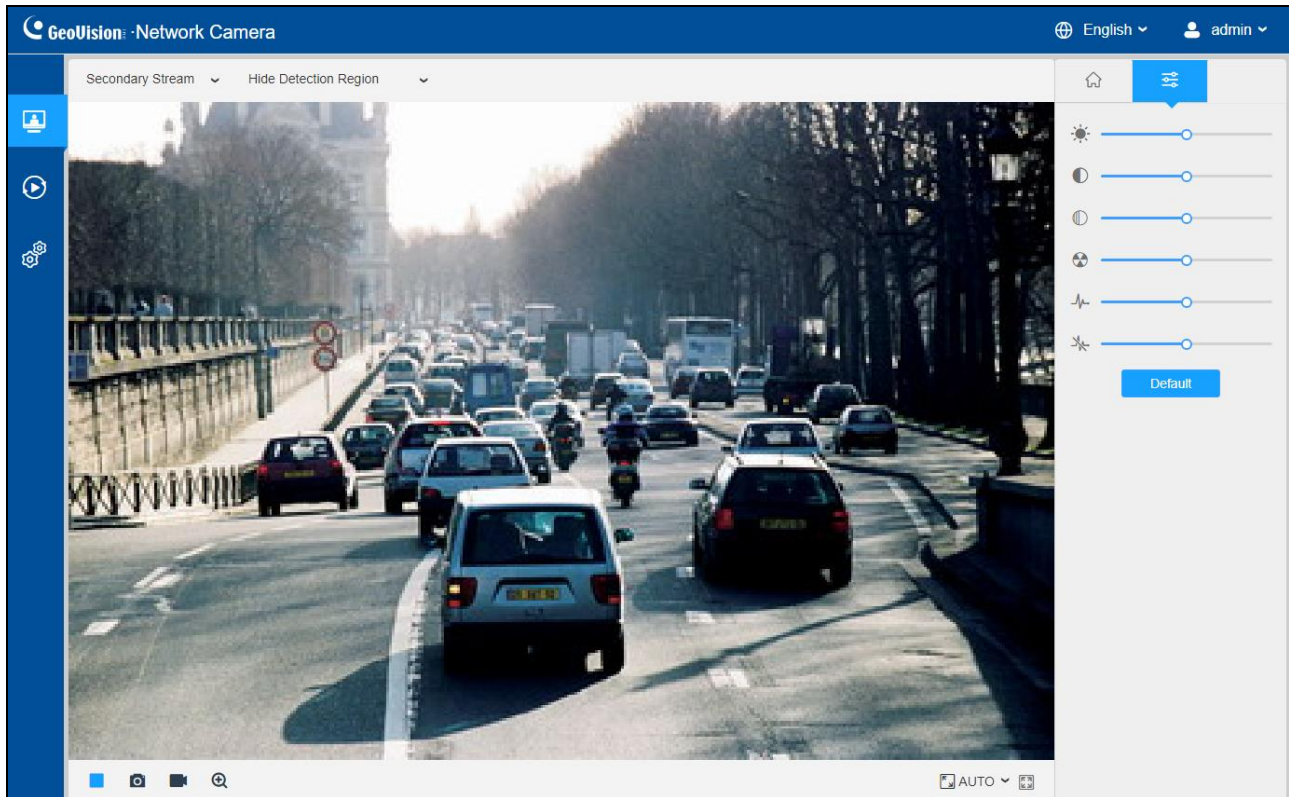
The camera can be used with the most standard operating systems and browsers. And the camera was upgraded to support Plugin-Free Mode. In Plugin-Free Mode, you can preview the video on the browser without plugin. Currently Plugin-Free Mode is supported in Firefox & Google Chrome & Safari & Edge browser for Windows system, MAC system, iOS system and Android system.

Both H.265 & H.264 video codecs are supported in Plugin-Free Mode for camera, and it will play the secondary stream by default.



# Chapter 6. Live View


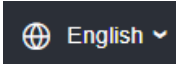
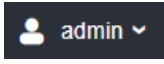
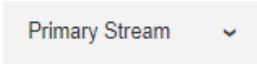
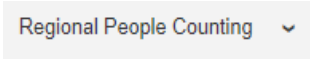





## 6.1 Live Video





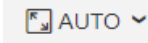


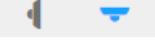

After logging in the network camera web GUI successfully, user is allowed to view live video as follows.




**Table 2. Description of the buttons**

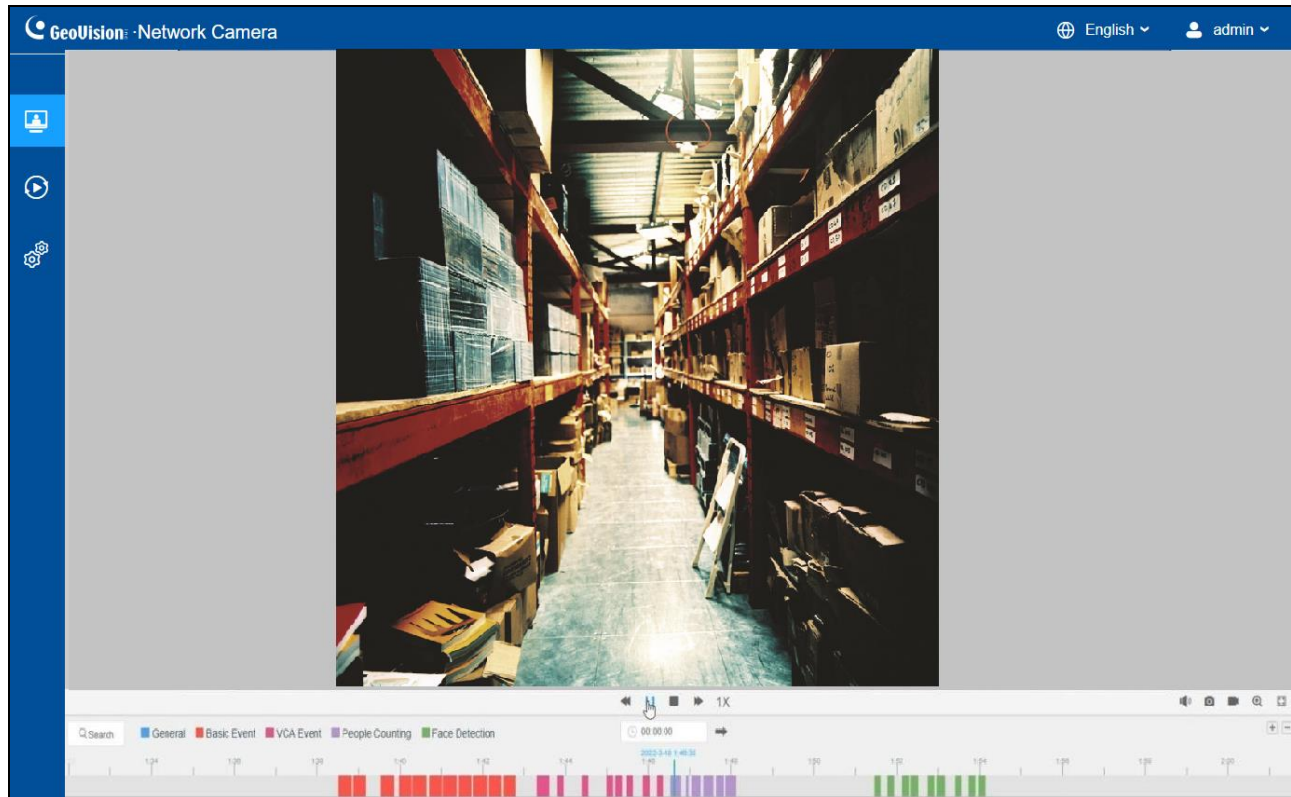
No.	Parameter	Description
1	 Live Video	Click to access the live view page.
2	 Playback	Click to access the playback page.

3	 Settings	Click to access the configuration page.
4		Click to select system language.
5		Display the user name and click to logout.
6		Choose the stream ( <b>Primary/Secondary/Tertiary</b> ) to show on the current video window.
7		Choose the options ( <b>Hide Detection Region/Region Entrance/ Region Exiting/Advanced Motion/Line Crossing/Loitering/ People Counting/Object Left/Object Remove/Regional People Counting</b> ) to hide/display detection region on the current video window.
8	 Recording	When recording, the icon appears.
9	 Alarm	When an alarm of VCA event was triggered, the icon appears.
10	 Alarm	When an alarm of people counting was triggered, the icon appears.
11	 Alarm	When an alarm of Motion Detection was triggered, the icon appears.
12	 Alarm	Except for the three kinds of alarms above, when other alarms were triggered, the icon appears.

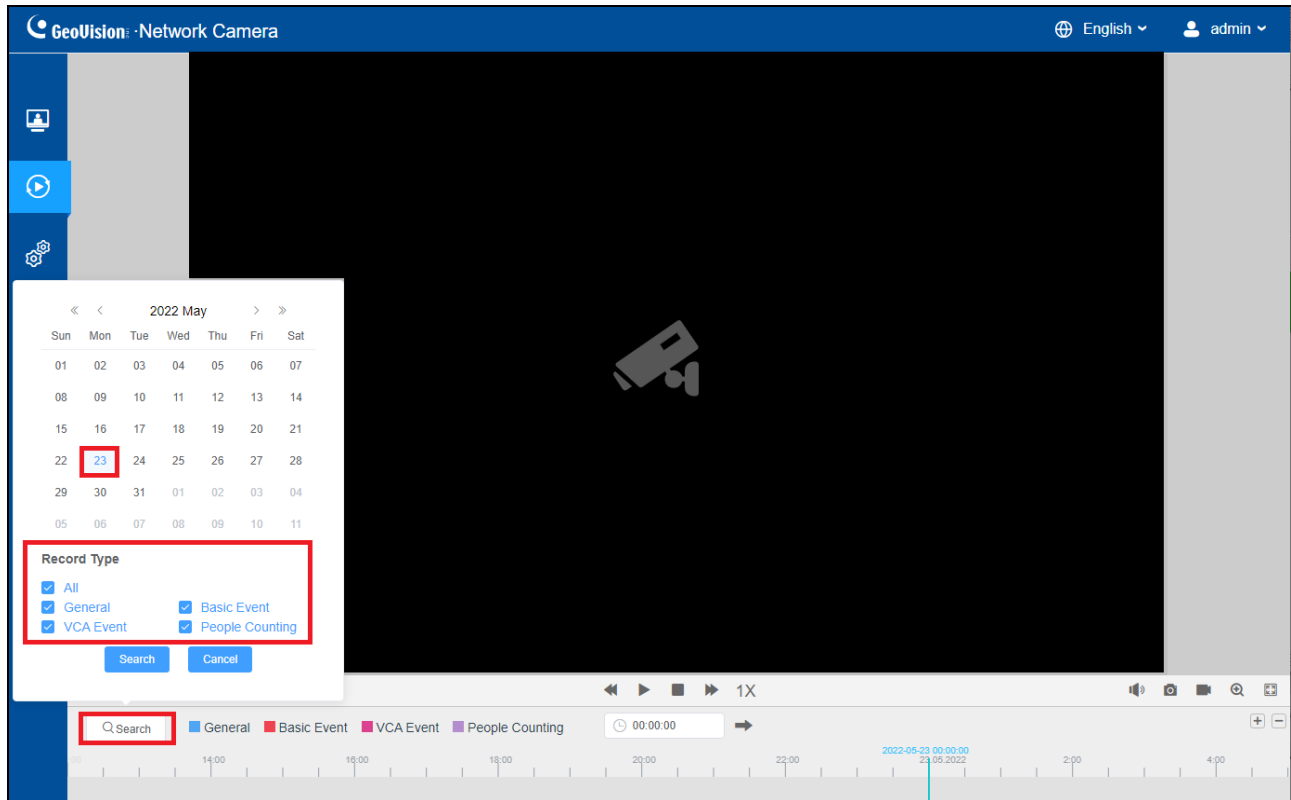
13	 Stop/Play	<b>Stop/Play</b> live view.
14	 Snapshot	Click to capture the current image and save to the configured path.
15	 Start/Stop Recording	Click to <b>Start Recording</b> video and save to the configured path. Click again to <b>Stop Recording</b> .
16	 Digital Zoom	When enabled, you can zoom in in a specific area of video image with your mouse wheel.
17	 Window Size	Click to display images at a window size.
18	 Full Screen	Click to display images at full-screen.
19	 Home	 Wall/Ceiling Installation Click to access installation. The AI algorithm will change according to the installation (Wall algorithm/Ceiling algorithm).
20		<p><b>Brightness:</b> Adjust the Brightness of the scene.</p> <p><b>Contrast:</b> Adjust the color and light contrast.</p> <p><b>Saturation:</b> Adjust the saturation of the image. Higher saturation makes colors appear “purer” while lower one appears more “washed-out”.</p> <p><b>Sharpness:</b> Adjust the sharpness of image. Higher sharpness sharpens the pixel boundary and makes the image look “clearer”.</p> <p><b>2D DNR/3D DNR:</b> Adjust the noise reduction level.</p> <p><b>Default:</b> Restore brightness, contrast and saturation to default settings.</p>

# Chapter 7. Playback



Click  to enter playback interface. In this part, you can search and playback the recorded video files stored in SD cards or NAS. The Playback interface is as below:




**Step 1:** Click the “**Search**” button, choose the date and record type when the window pops up.


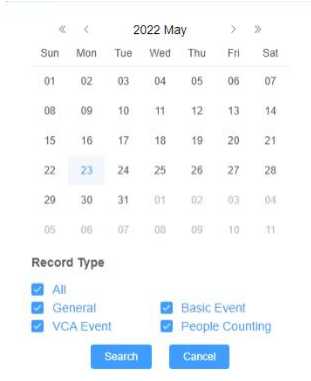




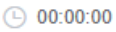



**Step 2:** The timeline displays the video files for the day and show different colors according to selected record type. Drag the progress bar with the mouse to locate the exact playback point as needed.







**Note:** You can also input the time and click the **Jump** button  to locate the playback point in the file. You can also click  to zoom in/out the progress bar.

**Step 3:** Click  to play the video files found on this date. The toolbar on the bottom of playback interface can be used to control playing progress.

**Table 3. Description of the buttons**

No.	Parameter	Description
		<p>Choose date to search recorded videos.</p> <p>Search the recorded videos by record type (<b>All/General/Basic Event/VCA Event/People Counting</b>). The timeline will show different colors according to selected record type as below:</p> 
1	 Speed Down/Speed Up/Speed	<p>Adjust the speed of video playback.</p> <p><b>Speed Down:</b> Includes 0.5X and 0.25X for Play.</p> <p><b>Speed Up:</b> Includes 2X and 4X for Play.</p> <p><b>Speed:</b> The default playback speed is 1X</p>
2	 Play/Pause	<p>Play/Pause the video.</p>
3	 Stop	<p>Stop the video.</p>
4	 Search Time	<p>Select the time that want to locate.</p>
5	 Jump	<p>Go To.</p>



6	 Mute	Click to enable the audio.
7	 Snapshot	Click to take a snapshot.
8	 Start/Stop recording	Click to start/stop recording.
9	 Digital Zoom	Click to zoom in/off.
10	 Full Screen	Full Screen.
11	 Time Expand/Narrow	Time narrow/expand.

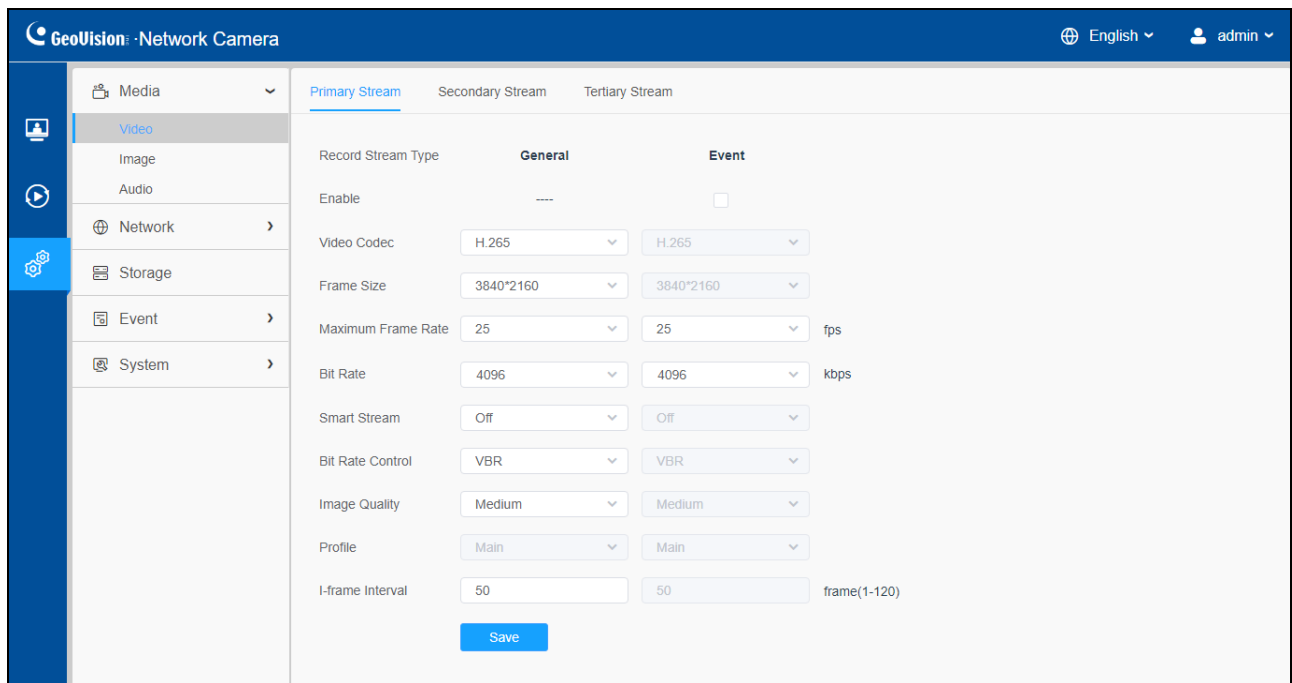
# Chapter 8. Settings

## 8.1 Media

### 8.1.1 Video

Stream parameters can be set in this module, adapting to different network environments and demands.

#### Primary Stream Settings



The screenshot shows the 'Primary Stream' settings for a 'Network Camera'. The interface is divided into a left sidebar with navigation options (Media, Video, Image, Audio, Network, Storage, Event, System) and a main content area. The 'Video' section is active, showing settings for 'General' and 'Event' streams. The 'General' stream is currently selected.

Record Stream Type	General	Event
Enable	---	<input type="checkbox"/>
Video Codec	H.265	H.265
Frame Size	3840*2160	3840*2160
Maximum Frame Rate	25	25
Bit Rate	4096	4096
Smart Stream	Off	Off
Bit Rate Control	VBR	VBR
Image Quality	Medium	Medium
Profile	Main	Main
I-frame Interval	50	50

Units: fps for Maximum Frame Rate, kbps for Bit Rate, frame(1-120) for I-frame Interval.

A 'Save' button is located at the bottom of the settings area.

## Secondary Stream Settings

GeoVision - Network Camera English ▼ admin ▼

- Media ▼
- Video
- Image
- Audio
- Network ▶
- Storage
- Event ▶
- System ▶

Primary Stream    Secondary Stream    Tertiary Stream

---

Enable

Video Codec H.264 ▼

Frame Size 640\*360 ▼

Maximum Frame Rate 30 ▼ fps

Bit Rate 512 ▼ kbps

Smart Stream Off ▼

Bit Rate Control VBR ▼

Image Quality Medium ▼

Profile Main ▼

I-frame Interval 50 ▼ frame(1-120)

[Save](#)

## Tertiary Stream Settings

GeoVision - Network Camera English ▼ admin ▼

- Media ▼
- Video
- Image
- Audio
- Network ▶
- Storage
- Event ▶
- System ▶

Primary Stream    Secondary Stream    Tertiary Stream

---

Enable

Video Codec H.264 ▼

Frame Size 640\*480 ▼

Maximum Frame Rate 25 ▼ fps

Bit Rate 1024 ▼ kbps

Smart Stream Off ▼

Bit Rate Control VBR ▼

Image Quality Medium ▼

Profile Main ▼

I-frame Interval 50 ▼ frame(1-120)

[Save](#)

**Table 4. Description of the buttons**

Parameters	Function Introduction
<p><b>Record Stream Type</b></p>	<p><b>General &amp; Event</b> are available only for <b>Primary Stream</b>. <b>General</b> refers to continuous record video, while <b>Event</b> includes events that can trigger alarms, such as Motion, Exception, and so on.</p> <p>This item can separately set different bit rate and frame rate for different Recording Stream Types. If user chooses <b>Event</b>, video will be recorded according to the configuration of video stream type when an event happens, thereby greatly reducing the recording storage space.</p>
<p><b>Enable Event Stream</b></p>	<p>This item is optional only if you selected the <b>Event</b>.</p>
<p><b>Video Codec</b></p>	<p>H.265/H.264/MJPEG are available.</p>
<p><b>Frame Size</b></p>	<p><b>Primary Stream</b> includes 3840 x 2160, 3456 x 1936, 3200 x 1800, 2880 x 1624, 2560 x 1440, 1920 x 1080, 1280 x 720.</p> <p>For <b>Secondary Stream</b>, it includes 1280 x 720, 704 x 576, 640 x 480, 640 x 360, 352 x 288, 320 x 240.</p> <p>For <b>Tertiary Stream</b>, it includes 1280 x 720, 704 x 576, 640 x 480, 640 x 360, 352 x 288, 320 x 240.</p> <p><b>Note:</b> The options of <b>Frame Size</b> are variable according to the model.</p>
<p><b>Maximum Frame Rate</b></p>	<p>Maximum refresh frame rate of per second and it is variable according to the mode.</p>
<p><b>Bit Rate</b></p>	<p>Transmitting bits of data per second, this item is optional only if you select the H.265/ H.264</p> <p>Set the bitrate to 16 ~ 16384 Kbps. The higher value corresponds to the higher video quality, and the higher bandwidth is required as well.</p>
<p><b>Smart Stream</b></p>	<p>Optionally turn <b>On/Off</b> Smart Stream mode. Smart Stream mode remarkably reduces the bandwidth and the data storage requirements for network cameras while ensuring the high quality of images, and it is a 10-level adjustable codec.</p> <p><b>Level:</b> Level 1~10 is available as needed.</p>

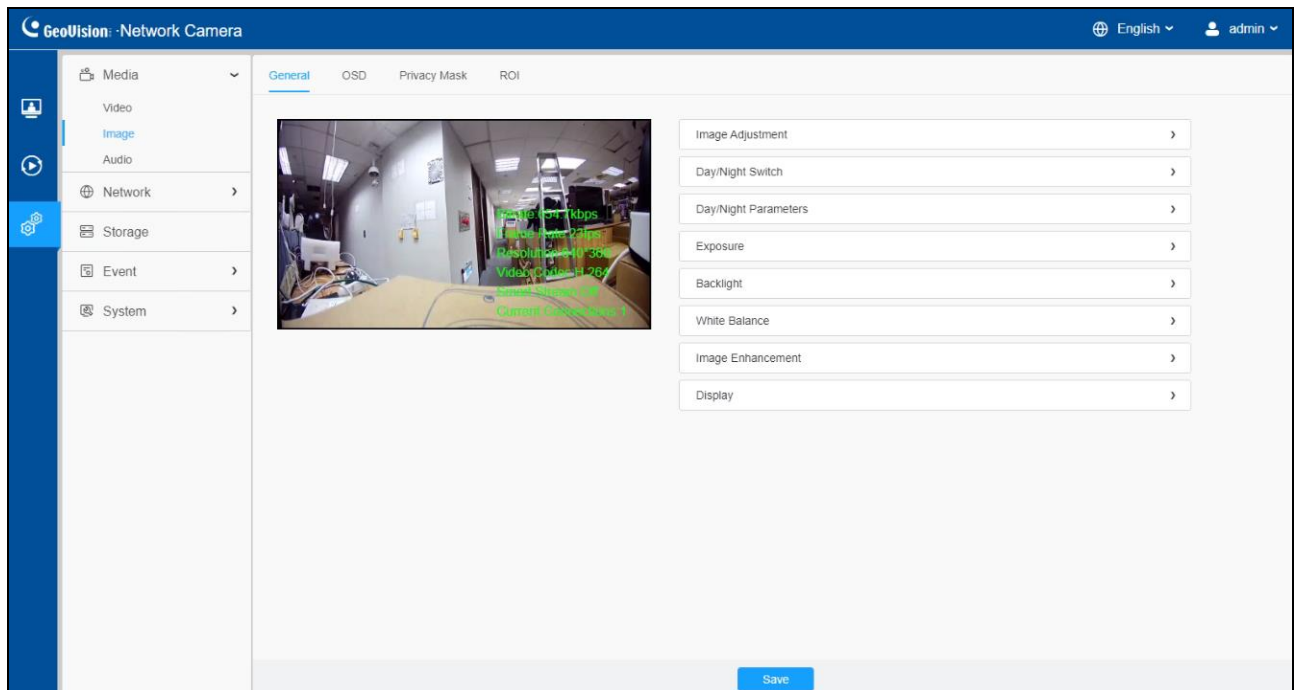
<b>Bit Rate Control</b>	<b>CBR:</b> Constant Bitrate. The rate of CBR output is constant. <b>VBR:</b> Variable Bitrate. VBR files vary the amount of output data per time segment.
<b>Image Quality</b>	<b>Low/Medium/High</b> are available, this item is optional only if you select VBR.
<b>Profile</b>	The option is for H.264, <b>Main/High/Base</b> can be selected as needed.
<b>I-frame Interval</b>	Set the I-frame interval to 1~120, 50 for the default. This item is optional only if you select the H.265/H.264. The number must be a multiple of the number of frames.

## 8.1.2 Image

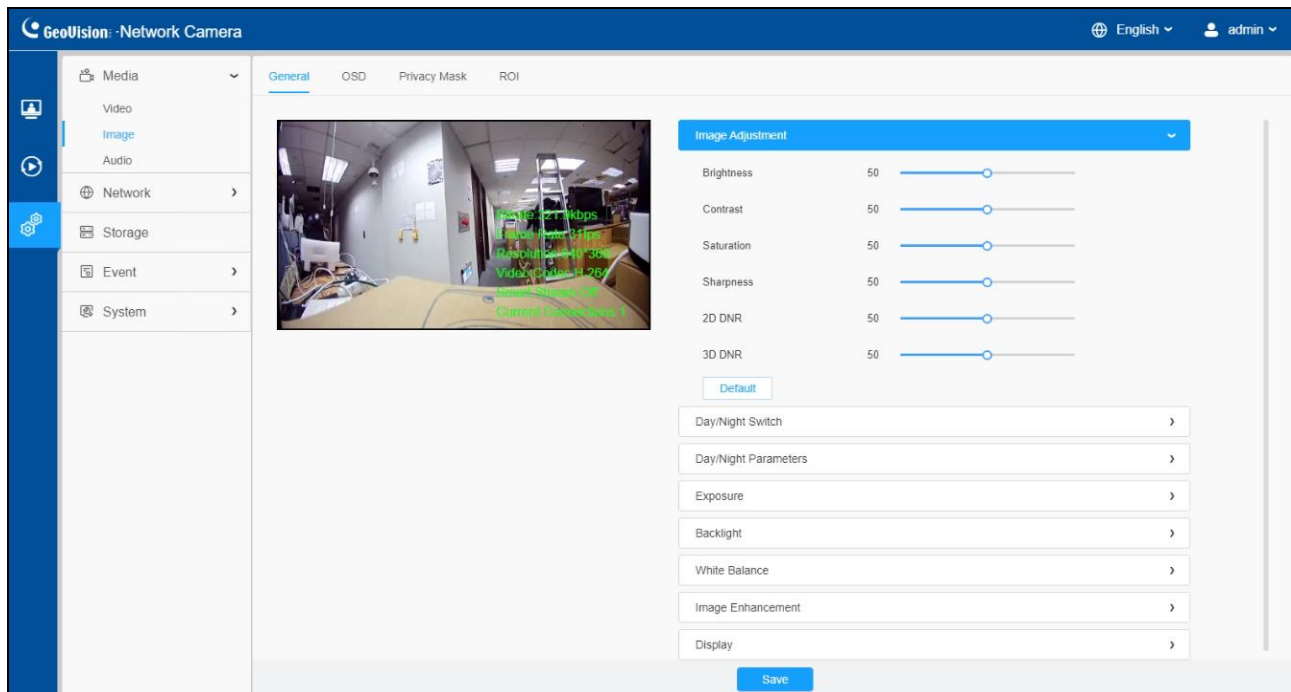
General settings of image including the image adjustment, day/night setting and image enhancement can be set in this module. OSD (On Screen Display) content, privacy mask and video time can be displayed to rich the image information.

### 8.1.2.1 General


General settings of image including Image Adjustment, Day/Night Switch, Day/Night Parameters, Exposure, Backlight, White Balance, Image Enhancement and Display can be set in this module.



## [Image Adjustment]



**Table 5. Description of the buttons**

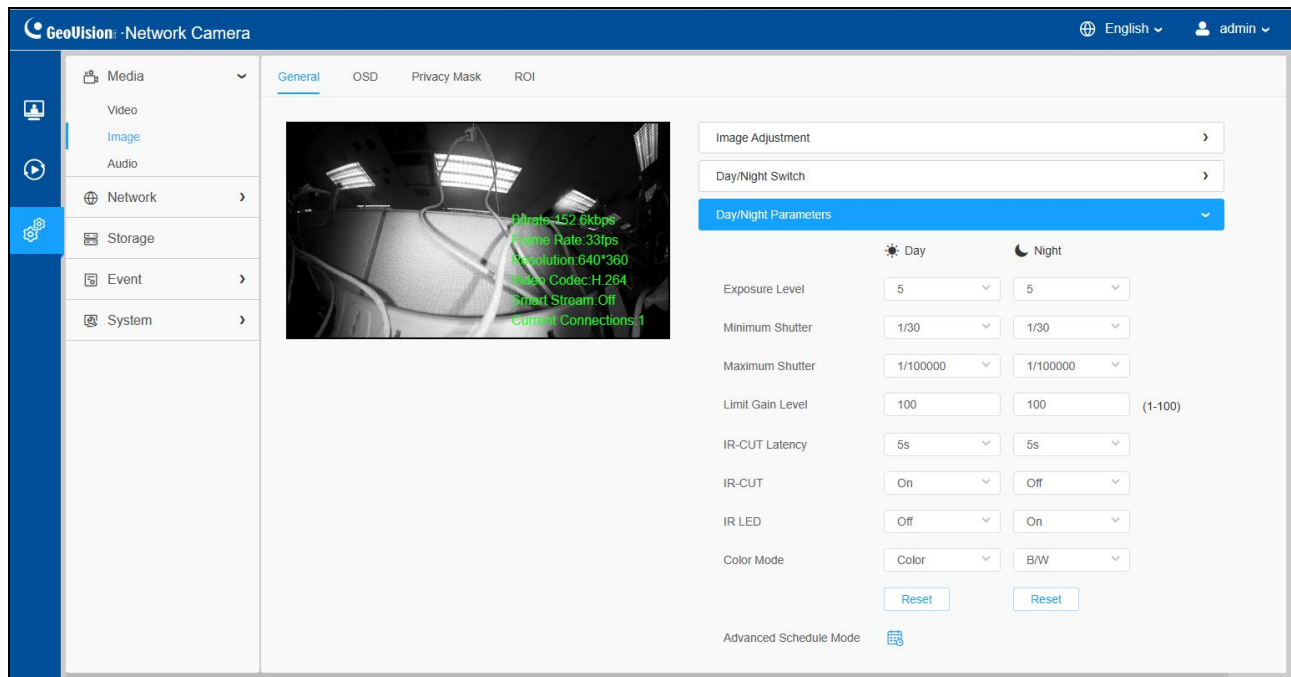
Parameters	Function Introduction
<b>Brightness</b>	Adjust the Brightness of the scene.
<b>Contrast</b>	Adjust the color and light contrast.
<b>Saturation</b>	Adjust the Saturation of the image. Higher Saturation makes colors appear “purer” while lower one appears more “washed-out”.
<b>Sharpness</b>	Adjust the Sharpness of image. Higher Sharpness sharpens the pixel boundary and makes the image looks “clearer”.
<b>2D DNR/3D DNR</b>	Adjust the noise reduction level.
	Restore brightness, contrast and saturation to default settings.






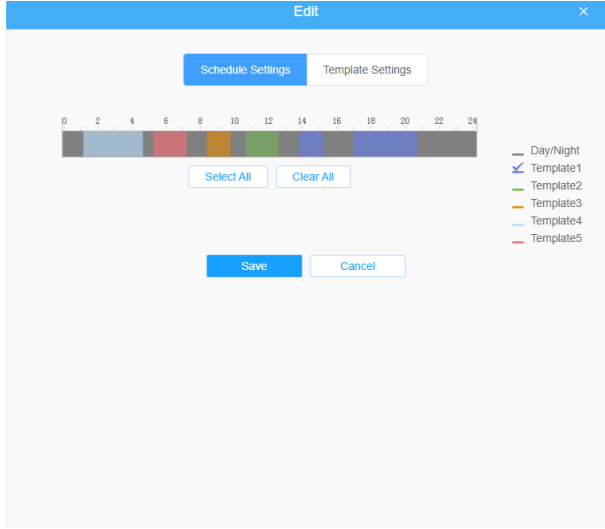
<p><b>Day/Night Switch</b></p>	<p><b>Night to Day Sensitivity:</b> This is the sensitivity for switching Night Mode to Day Mode. When IR Light Sensor Current Value is higher than this value, it will switch Night Mode to Day Mode.</p> <p><b>Note:</b> The three buttons are optional only if you select Auto Mode.</p> <p><b>Start Time of Night:</b> You can set the time for start the Night Mode.</p> <p><b>End Time of Night:</b> You can set the time for start the Day Mode.</p> <p><b>Note:</b> The two buttons are optional only if you select Customize.</p>
<p><b>Smart IR Mode</b></p>	<p>Support for <b>Customize</b> mode.</p> <p><b>IR LED Level:</b> The current LED light value.</p>

**[Day/Night Parameters]**

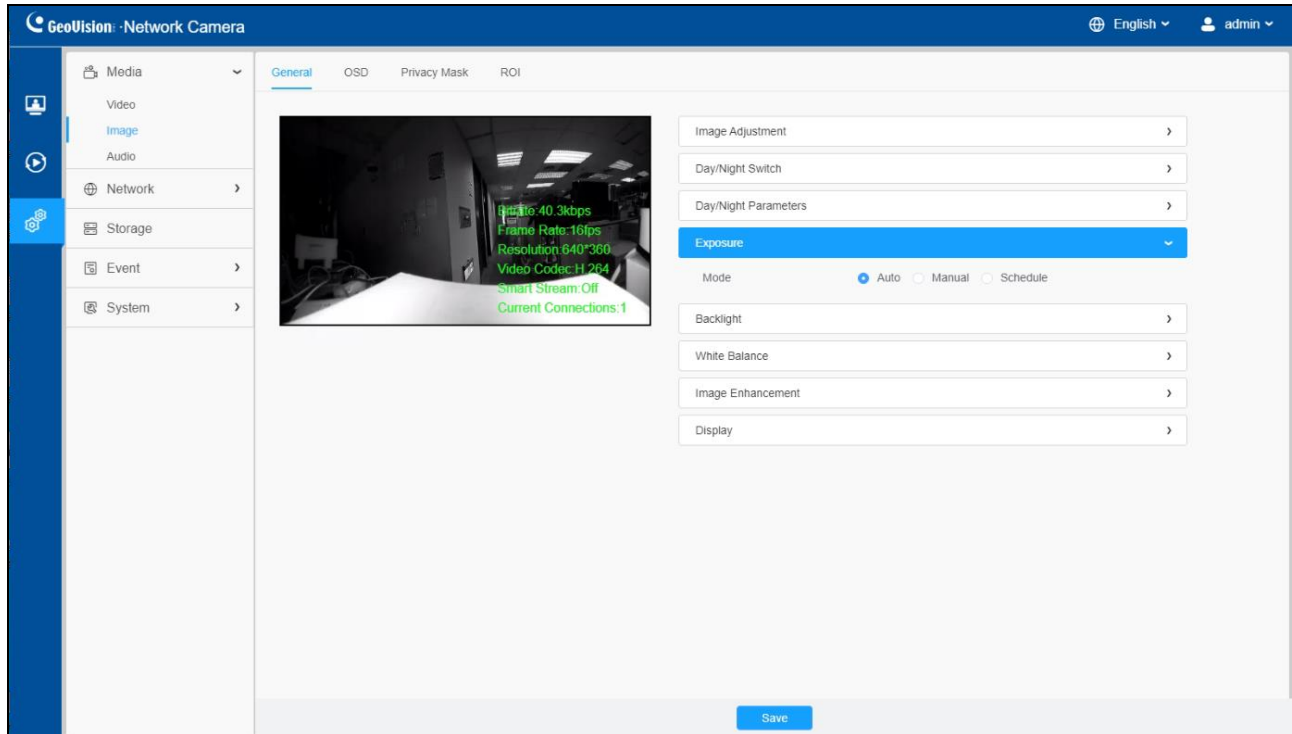


The screenshot displays the GeoVision Network Camera web interface. The top navigation bar includes the GeoVision logo, 'Network Camera', language settings (English), and a user profile (admin). A left sidebar contains menu items: Media (Video, Image, Audio), Network, Storage, Event, and System. The main content area is divided into tabs: General, OSD, Privacy Mask, and ROI. The 'General' tab is active, showing a live video feed of a camera lens with technical data overlaid: Bitrate: 452 kbps, Frame Rate: 33fps, Resolution: 640\*360, Video Codec: H.264, Smart Stream: Off, and Current Connections: 1. To the right of the video feed is the 'Day/Night Parameters' configuration panel. This panel has two columns for 'Day' and 'Night' settings. Parameters include Exposure Level (5), Minimum Shutter (1/30), Maximum Shutter (1/100000), Limit Gain Level (100), IR-CUT Latency (5s), IR-CUT (On/Off), IR LED (Off/On), and Color Mode (Color/B/W). Each parameter has a dropdown menu or input field. There are 'Reset' buttons for each column. At the bottom, there is an 'Advanced Schedule Mode' option with a calendar icon.

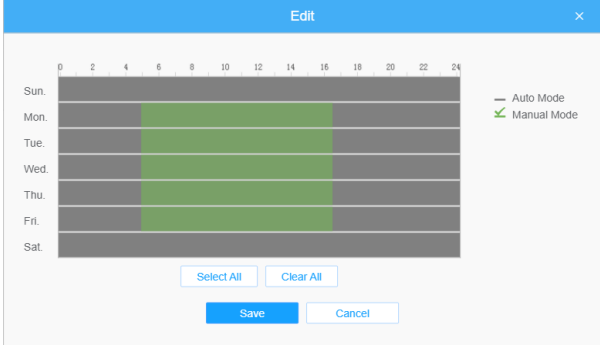
**Table 7. Description of the buttons**

Parameters	Function Introduction
<b>Exposure Level</b>	Level 0~10 is available to meet your need.
<b>Minimum Shutter</b>	Minimum Shutter is the same as Maximum Exposure Time. Set the minimum Shutter to 1~1/100000s.
<b>Maximum Shutter</b>	Maximum Shutter is the same as Minimum Exposure Time. Set the maximum Shutter to 1~1/100000 s.
<b>Limit Gain Level</b>	Set the Limit Gain Level to 1~100.
<b>IR-CUT Latency</b>	The interval time of switching one mode to another.
<b>IR-CUT</b>	Turn on/off IR-CUT.
<b>IR LED</b>	Turn on/off IR-LED.
<b>Color Mode</b>	Select B/W or Color mode.
<p><b>Advanced Schedule Mode</b> </p>	<p>Here you can customize your special demands for different time, then the Day mode and Night mode will switch automatically according to your settings.</p> 

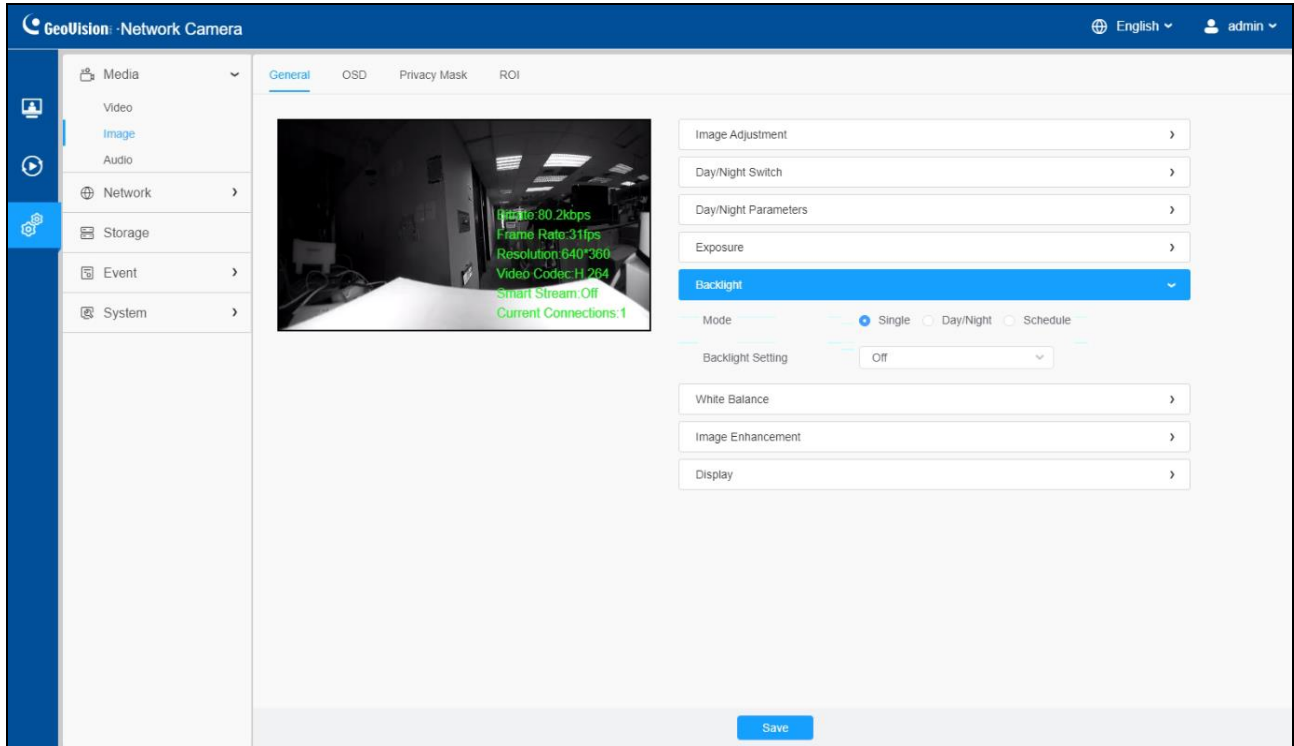
## [Exposure]



**Table 8. Description of the buttons**

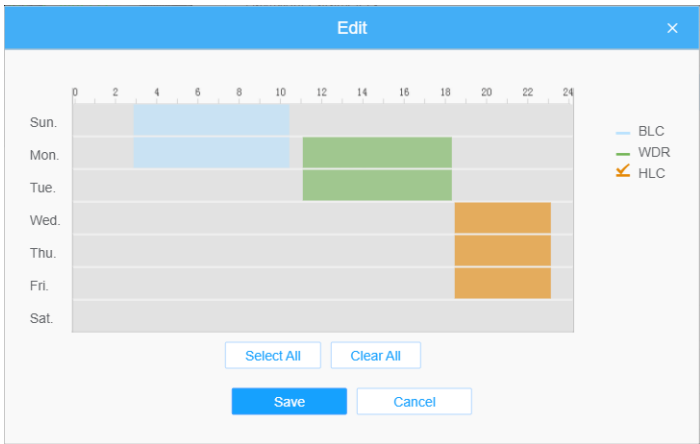
Parameters	Function Introduction
<p style="text-align: center;"><b>Exposure Mode</b></p>	<p><b>Auto Mode, Manual Mode and Schedule Mode</b> are available.</p> <p><b>Auto Mode:</b> The camera will adjust the brightness according to the light environment automatically.</p> <p><b>Manual Mode:</b> The camera will adjust the brightness according to the value you set, you can set the exposure time from 1~1/100000 s, the higher the value is, the brighter the image is.</p> <p><b>Schedule Mode:</b> You can customize the schedule to enable/disable Auto Mode and Manual Mode.</p> 

# [Backlight]

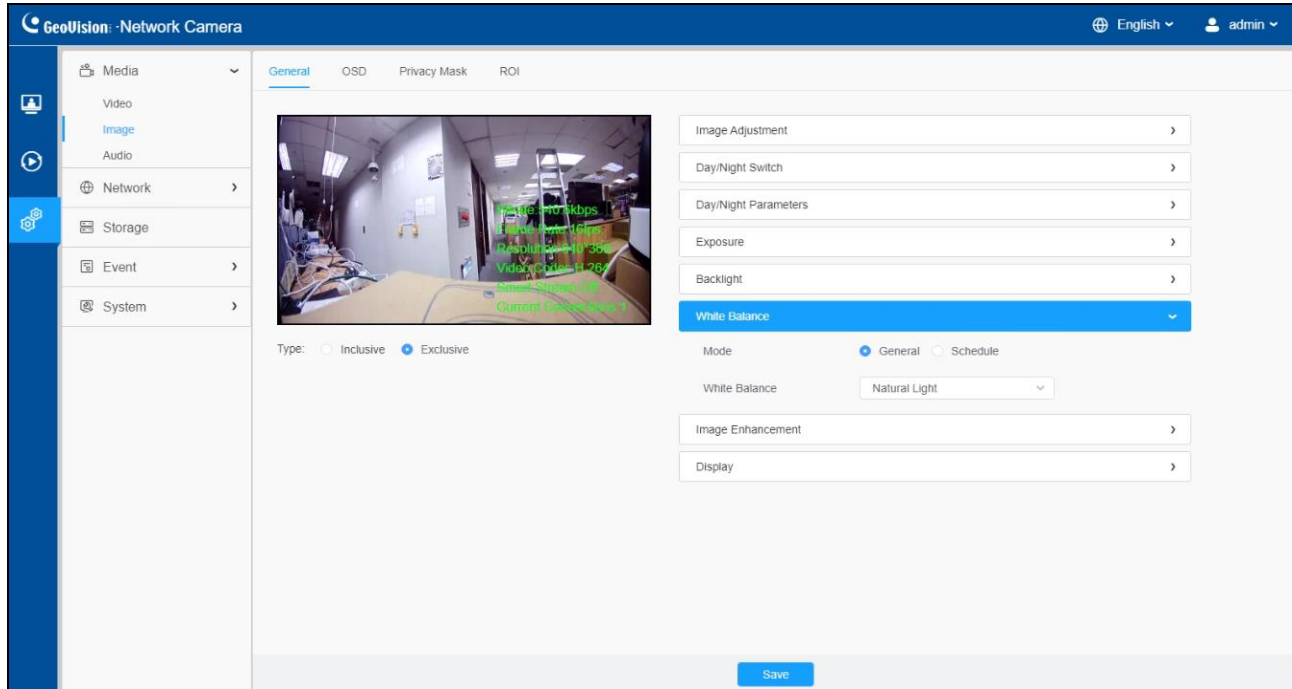


The screenshot displays the GeoVision Network Camera web interface. The top navigation bar includes the GeoVision logo, the text "Network Camera", a language dropdown set to "English", and a user profile dropdown for "admin". A left sidebar contains a menu with icons for Media, Video, Image, Audio, Network, Storage, Event, and System. The main content area is divided into tabs: "General", "OSD", "Privacy Mask", and "ROI". The "General" tab is active, showing a live video feed of an office interior with green OSD text overlaying technical details: "Bit Rate: 80.2kbps", "Frame Rate: 31fps", "Resolution: 640\*360", "Video Codec: H.264", "Smart Stream: Off", and "Current Connections: 1". To the right of the video feed is a settings panel with expandable sections: "Image Adjustment", "Day/Night Switch", "Day/Night Parameters", "Exposure", "Backlight" (highlighted in blue), "White Balance", "Image Enhancement", and "Display". The "Backlight" section is expanded, showing "Mode" with radio buttons for "Single" (selected), "Day/Night", and "Schedule"; "Backlight Setting" with a dropdown menu set to "Off"; and "White Balance" with a dropdown menu set to "Off". A "Save" button is located at the bottom right of the settings panel.

**Table 9. Description of the buttons**

Parameters	Function Introduction
<p style="text-align: center;"><b>Backlight Mode</b></p>	<p><b>Single Mode:</b> Set single mode for <b>BLC/WDR/HLC</b>.</p> <p><b>Note:</b> WDR and General HLC are not supported while High Frame Rate is enabled.</p> <p><b>Day/Night Mode:</b> Support <b>BLC/WDR/HLC</b> on Day Mode/Night Mode separately.</p> <p><b>Schedule Mode:</b> Set schedule mode for <b>BLC/WDR/HLC</b>. You can customize the schedule to enable/disable <b>BLC/WDR/HLC</b> mode.</p> <div data-bbox="630 674 1325 1115" style="border: 1px solid black; padding: 5px;">  </div> <p><b>Configuration:</b> Three options are available: <b>BLC/WDR/HLC</b>.</p>

## [White Balance]




**Table 10. Description of the buttons**

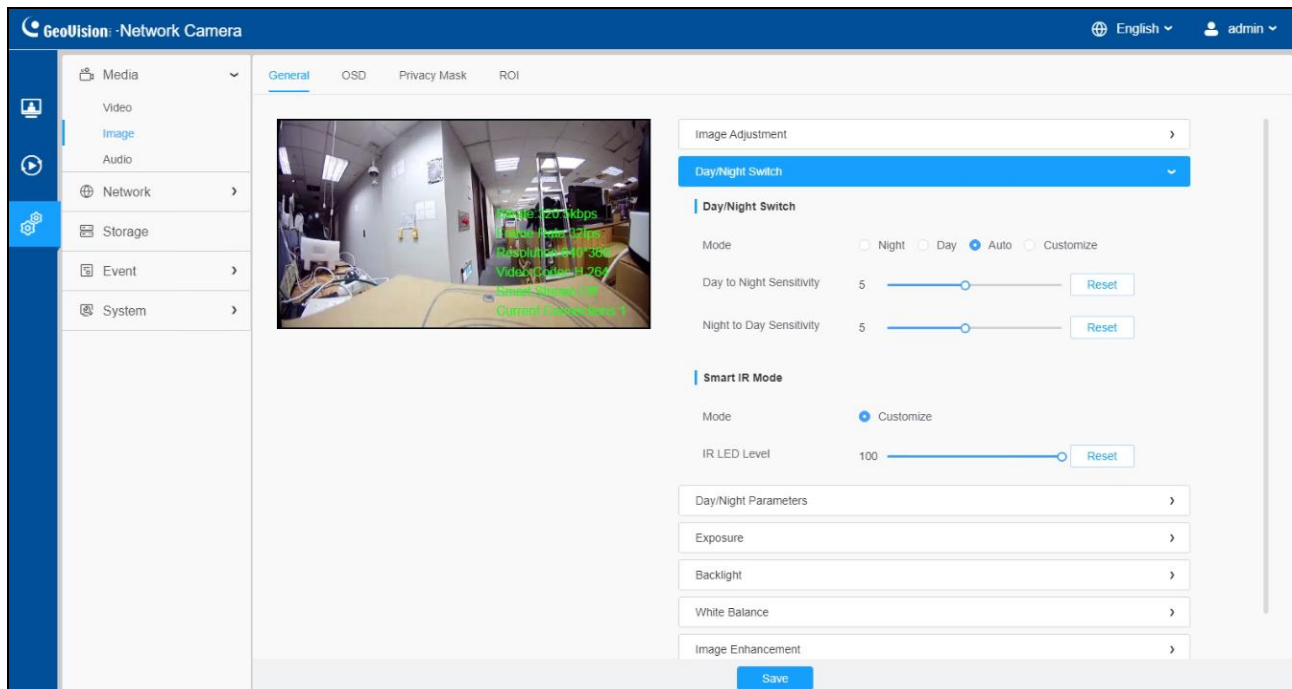
Parameters	Function Introduction
<p style="text-align: center;"><b>White Balance</b></p>	<p>To restore white objects, removed color distortion caused by the light of the environment.</p> <p><b>Auto White Balance:</b> This option will automatically enable the White Balance function.</p> <p><b>Manual White Balance:</b> Set <b>Red Gain Level</b> and <b>Blue Gain Level</b> manually.</p> <p><b>Incandescent Lamp:</b> Select this option when light is similar with incandescent lamp.</p> <p><b>Warm Light Lamp:</b> Select this option when light is similar with warm light lamp.</p> <p><b>Natural Light:</b> Select this option when there is no other light but natural light.</p> <p><b>Fluorescent Lamp:</b> Select this option when light is similar with Fluorescent Lamp.</p>

## White Balance

**Schedule mode:** Select this option to customize the schedule to enable/ disable above modes.



### [Image Enhancement]



**Table 11. Description of the buttons**

Parameters	Function Introduction
<b>IR Balance Mode</b>	<p>There is an option to turn On/Off the IR LED.</p> <p><b>IR Balance Mode</b> would avoid the problem of overexposure and darkness, and the IR LED will change according to the actual illumination.</p>
<b>Reduce Motion Blur</b>	<p>Enable this function to reduce the motion blur of objects effectively. You can adjust the <b>Deblur Level</b> from 1 to 100.</p>

[Display]

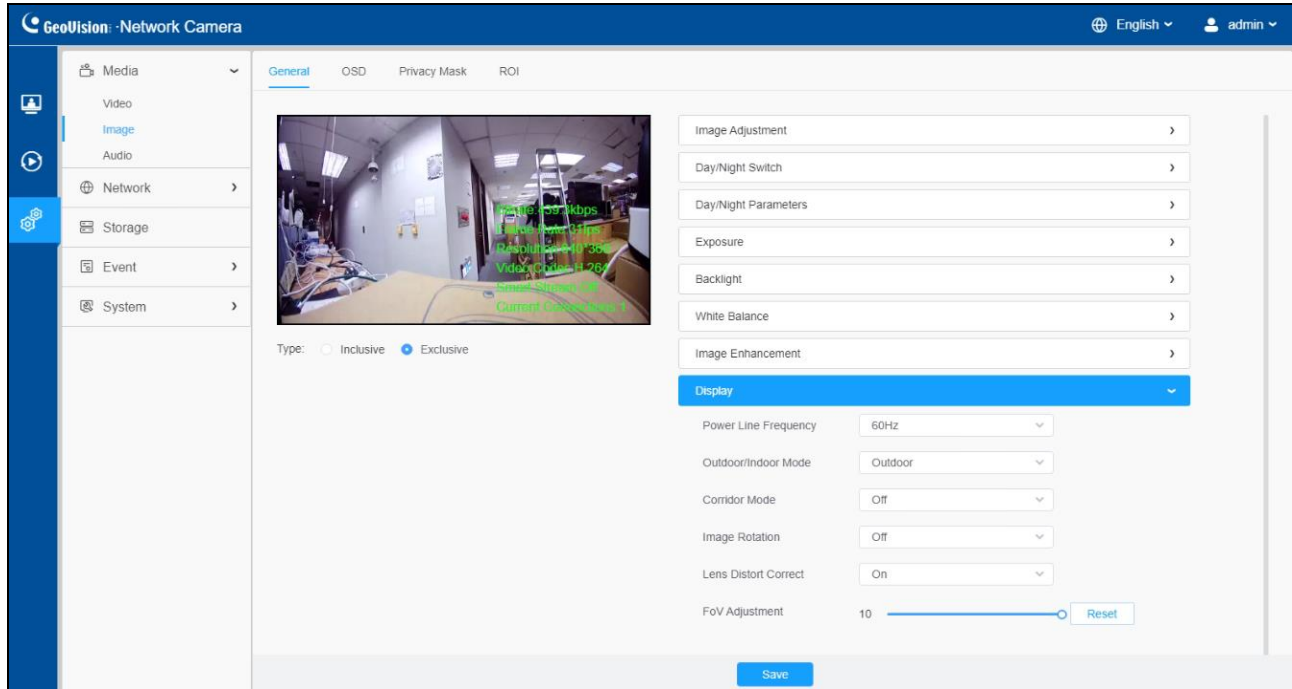


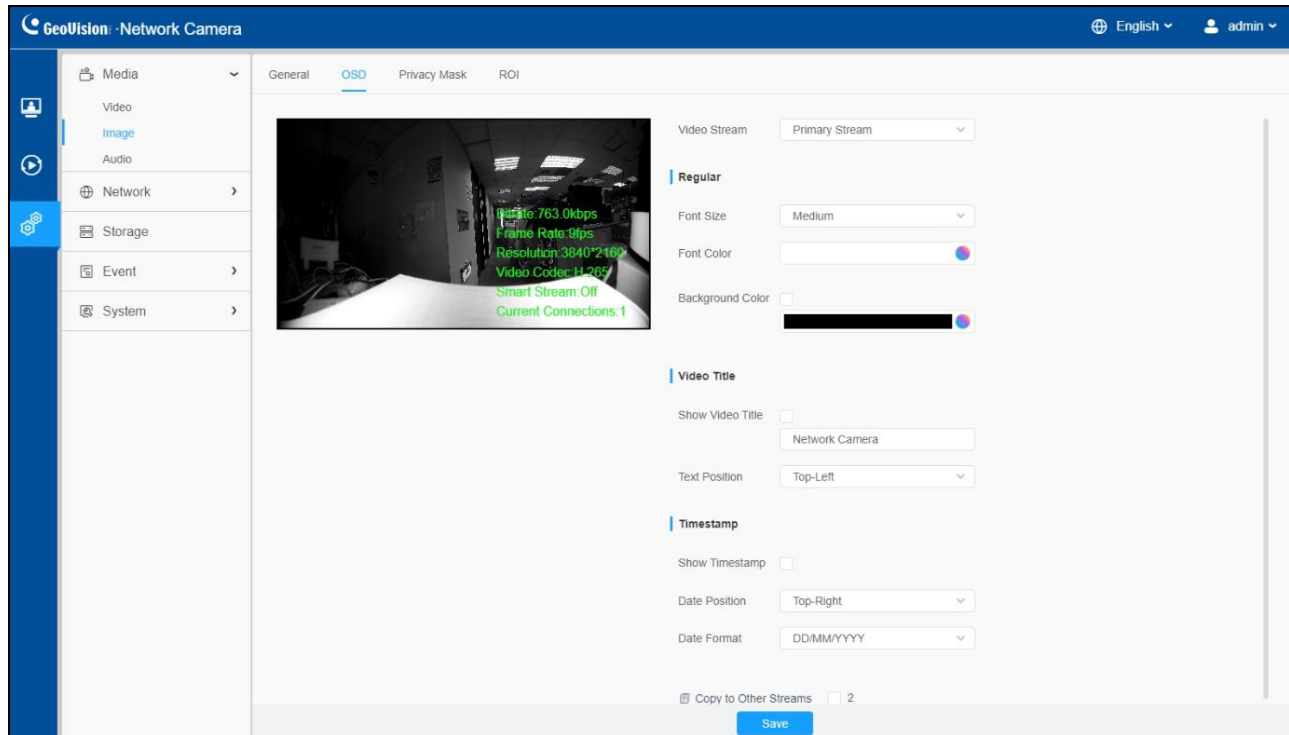
Table 12. Description of the buttons

Parameters	Function Introduction
<b>Power Line Frequency</b>	60Hz and 50Hz are available.
<b>Outdoor/Indoor Mode</b>	Select <b>Indoor</b> or <b>Outdoor</b> mode to meet your needs.
<b>Corridor Mode</b>	There are three options available, you can select one to meet your need. <b>Off</b> : Keep the image in normal direction. <b>Clockwise 90°</b> : Rotate the image by 90° clockwise. <b>Anticlockwise90°</b> : Rotate the image by 90° anticlockwise.
<b>Image Rotation</b>	There are four options available, you can select one to meet your need. <b>Off</b> : Keep the image in normal direction. <b>Rotating 180°</b> : Upside down the image. <b>Flip Horizontal</b> : Flip the image horizontally. <b>Flip Vertical</b> : Flip the image vertically.

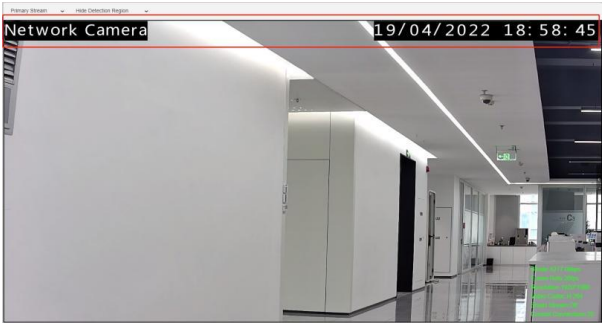


<b>Lens Distort Correct</b>	With this option enabled, the camera will prevent the image from distortion when resolution ratio is changed.
<b>FoV Adjustment</b>	Set the value from 1 to 10.

### 8.1.2.2 OSD



**Table 13. Description of the buttons**

Parameters	Function Introduction
<b>Video Stream</b>	Enable to set OSD for primary stream and secondary stream.
<b>Regular</b>	<p><b>Font Size:</b> <b>Smallest/Small/Medium/Large/Largest/Auto</b> are available for title and date.</p> <p><b>Font Color:</b> Enable to set different color for title and date.</p> <p><b>Background Color:</b> Enable to set different colors for display information background on screen.</p> <p>You can set different colors for font and background of image, then the image OSD will show as below:</p> 

<b>Video Title</b>	<b>Show Video Title:</b> Check the check box to show video title and customize the OSD content. <b>Text Position:</b> OSD display position on the image.
<b>Timestamp</b>	<b>Show Timestamp:</b> Check the checkbox to display date on the image. <b>Date Position:</b> Date display position on the image. <b>Date Format:</b> The format of date.
<b>Copy to Other Streams</b>	Copy the settings to other streams.

### 8.1.2.3 Privacy Mask

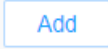
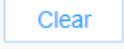


Privacy mask enables to cover certain areas on the live video to prevent certain spots in the surveillance area from being viewed and recorded.

#### [Privacy Mask]

You can select the color to cover certain areas on the live video.

**Note:** Up to 8 **privacy mask** areas are supported for GV-PBL8800/PDR8800.

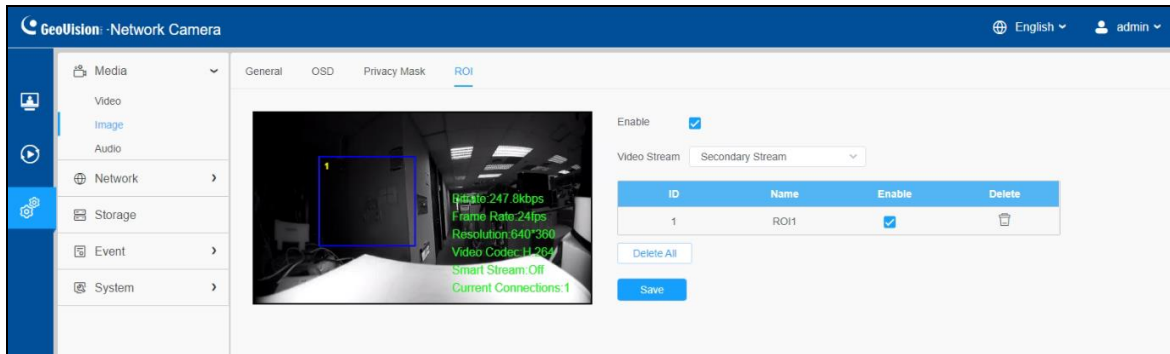
**Table 14. Description of the buttons**

Parameters	Function Introduction
<b>Enable</b>	Check the check box to enable the Privacy Mask function.
	Draw a privacy area on the live video as needed.
	Clear the area you draw on the live video.
<b>Delete All</b>	Clear all areas you draw before.
<b>Operation</b>	<p>Click the <b>Edit</b> button  before proceeding with the following configurations:</p> <ul style="list-style-type: none"> <li>• <b>Type:</b> Change the color of mask area. There are eight colors available: White, Black, Blue, Yellow, Green, Brown, Red, and Purple.</li> <li>• <b>Enable/Disable</b> <input type="checkbox"/> / <input checked="" type="checkbox"/> : Enable/disable the selected ROI areas.</li> <li>• <b>Delete</b>  : Delete the selected privacy mask area.</li> </ul>


### 8.1.2.4 ROI

Region of interest (often abbreviated as ROI), is a selected subset of samples within a dataset identified for a particular purpose. Users can select up to 8 key regions of a scene to transmit through separate streams for targeted preview and recording.

By using the ROI technology, more than 50% of bit rate can be saved and therefore less bandwidth demanded and the storage usage reduced. So according to this, you can set a small bit rate for high resolution.



**Table 15. Description of the buttons**

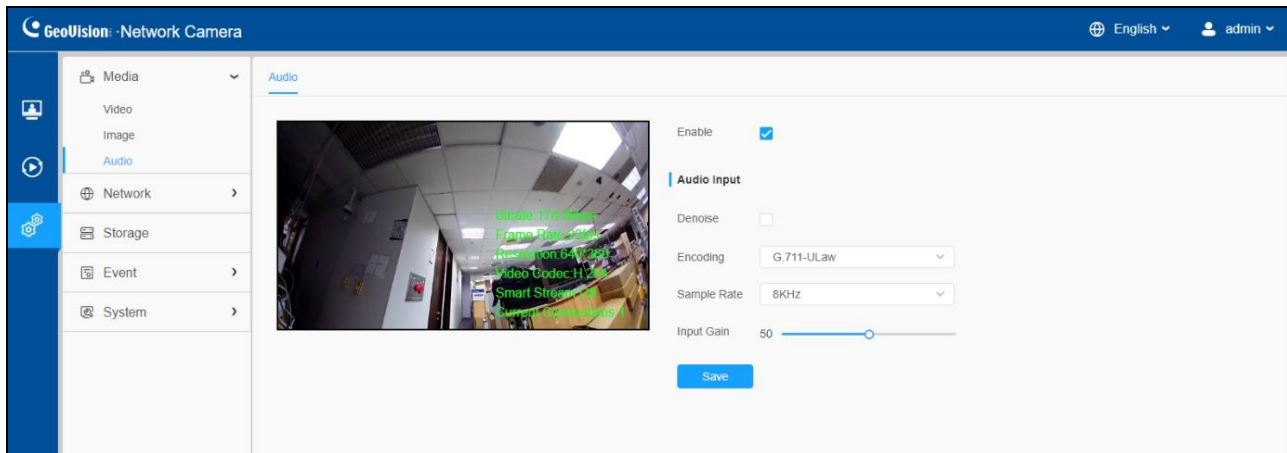
Parameters	Function Introduction
<b>Enable</b>	Check the checkbox to enable the ROI function.
<b>Video Stream</b>	Choose the Video Stream.
<b>Operation</b>	<p>After drawing the ROI key regions on the live view, click <b>Save</b>.</p> <ul style="list-style-type: none"> <li>• <b>Enable/Disable</b> <input type="checkbox"/> / <input checked="" type="checkbox"/> : Enable/disable the selected ROI areas.</li> <li>• <b>Delete</b>  : Delete the selected ROI areas.</li> </ul>
<b>Delete All</b>	Clear all areas you drew before.

**Note:** You can set a low bit rate. For example, you can set a bit rate with 512 Kbps and a resolution with 1080P, then you can see the image quality of ROI is clearer and more fluent than the other region.

## 8.1.3 Audio

### 8.1.3.1 Audio

This audio function allows you to hear the sound from the camera or transmit your sound to the camera side. Alarm can be triggered when the audio input is above a certain alarm level you set, and configured audio can be played when an alarm occurs.



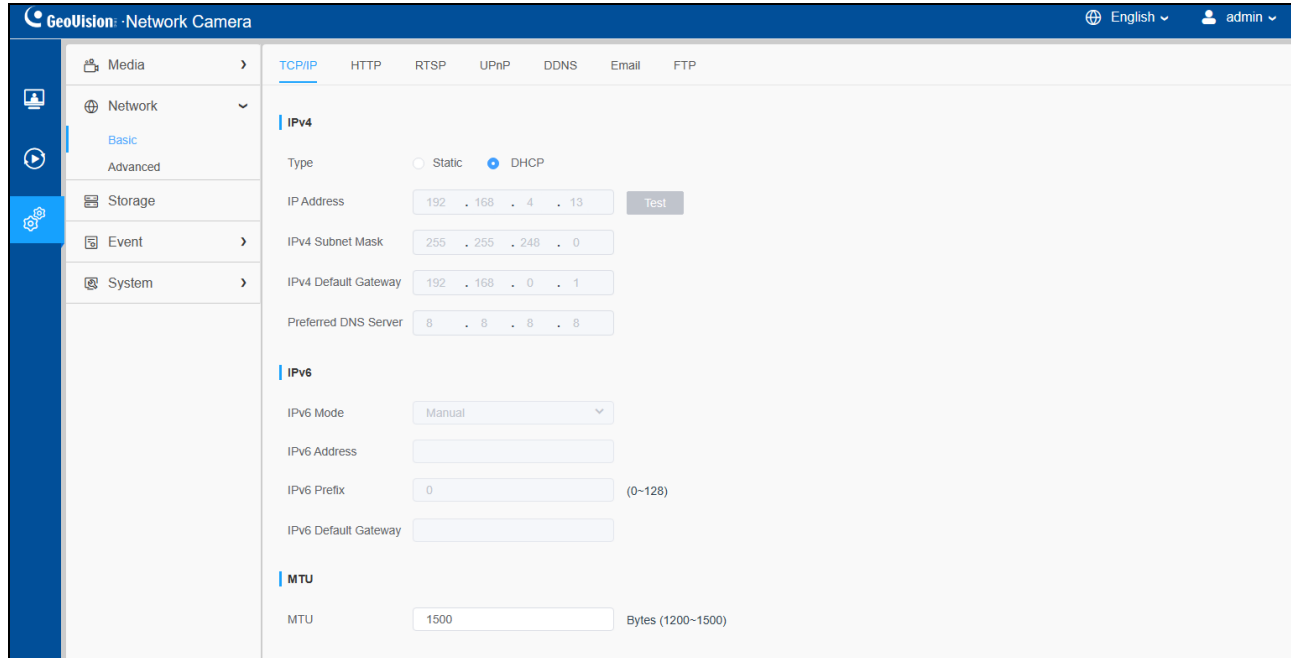
**Table 16. Description of the buttons**

Parameters	Function Introduction
<b>Enable</b>	Check on the checkbox to enable audio feature.
<b>Audio Input</b>	<p><b>Denoise:</b> Set it as <b>On/Off</b>. When you set the function on, the noise detected can be filtered.</p> <p><b>Encoding:</b> G.711-ULaw, and G.711-ALaw are available.</p> <p><b>Sample Rate:</b> 8KHz, 16KHz, 32KHz, and 48KHz are available.</p> <p><b>Input Gain:</b> Input audio gain level, 0-100.</p>

## 8.2 Network

### 8.2.1 Basic

#### 8.2.1.1 TCP/IP

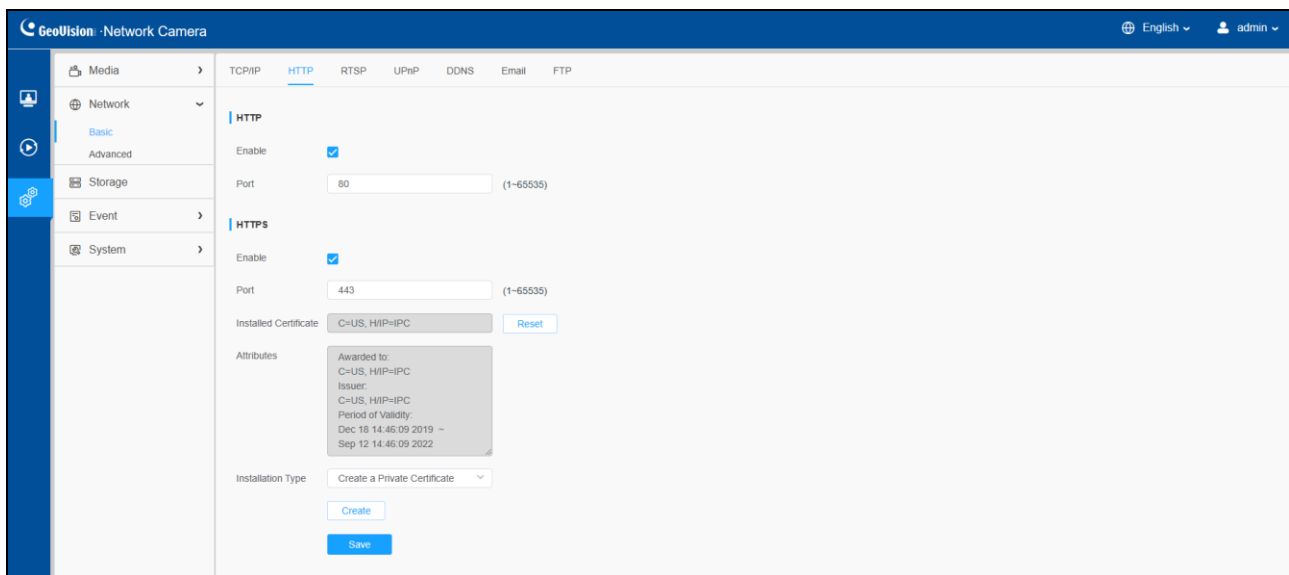


**Table 17. Description of the buttons**

Parameters	Function Introduction
IPv4	<p><b>Type:</b> <b>Static</b> Type and <b>DHCP</b> Type are optional for user to get IPv4 address automatically or use fixed IP address.</p> <p><b>IP Address:</b> An address that used to identify a network camera on the network.</p> <p><b>Note:</b> The <b>Test</b> button is used to test if the IP is conflicting.</p> <p><b>IPv4 Subnet Mask:</b> It is used to identify the subnet where the network camera is located.</p> <p><b>IPv4 Default Gateway:</b> The default router address.</p> <p><b>Preferred DNS Server:</b> The DNS Server translates the domain name to IP address.</p>

<b>IPv6</b>	<p><b>IPv6 Mode:</b> Choose different modes for IPv6: <b>Manual/Route Advertisement/ DHCPv6.</b></p> <p><b>IPv6 Address:</b> IPv6 Address used to identify a network camera on the network.</p> <p><b>IPv6 Prefix:</b> Define the prefix length of IPv6 address.</p> <p><b>IPv6 Default Gateway:</b> The default router IPv6 address.</p>
<b>MTU</b>	Maximum Transmission Unit. The default value is 1500. You can customize the value from 1200 to 1500 as needed.
<b>Save</b>	Save the configuration.

### 8.2.1.2 HTTP



**Table 18. Description of the buttons**

Parameters	Function Introduction
<b>HTTP</b>	<p><b>Enable:</b> Start or stop using HTTP.</p> <p><b>Port:</b> Web GUI login port, the default is 80, the same with ONVIF port.</p>



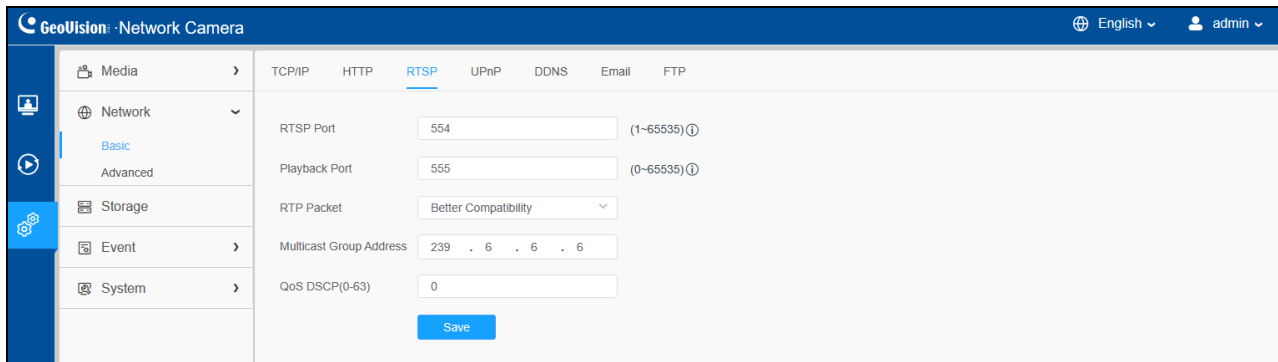
<b>HTTPs</b>	<p><b>Enable:</b> Start or stop using HTTPs.</p> <p><b>Port:</b> Web GUI login port via HTTPS, the default is 443.</p> <p><b>Installed Certificate/Attributes/Installation Type:</b> Upload and set the SSL certificate.</p>
<input type="button" value="Save"/>	Save the configuration.

**Table 19. HTTP URL are as below:**

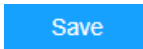
Stream	URL
<b>Main Stream</b>	http://username:password@IP:port/ipcam/mjpeg.cgi
<b>Secondary Stream</b>	http://username:password@IP:port/ipcam/mjpegcif.cgi
<b>Tertiary Stream</b>	http://username:password@IP:port/ipcam/mjpegthird.cgi

**Note:** You need to change the codec type of streams to MJPEG.

### 8.2.1.3 RTSP



**Table 20. Description of the buttons**

Parameters	Function Introduction
<b>RTSP Port</b>	The port of RTSP, the default is 554.
<b>Playback Port</b>	Playback Port The port of playback, the default is 555. <b>Note:</b> Port 0 means closing playback function.
<b>RTP Packet</b>	There are <b>Better Compatibility</b> and <b>Better Performance</b> two options, if an issue occurs on your camera's image, please switch this option.
<b>Multicast Group Address</b>	Support multicast function.
<b>QoS DSCP</b>	The valid value range of the DSCP is 0-63.
	Save the configuration.

**Table 21. RTSP URL are as below:**

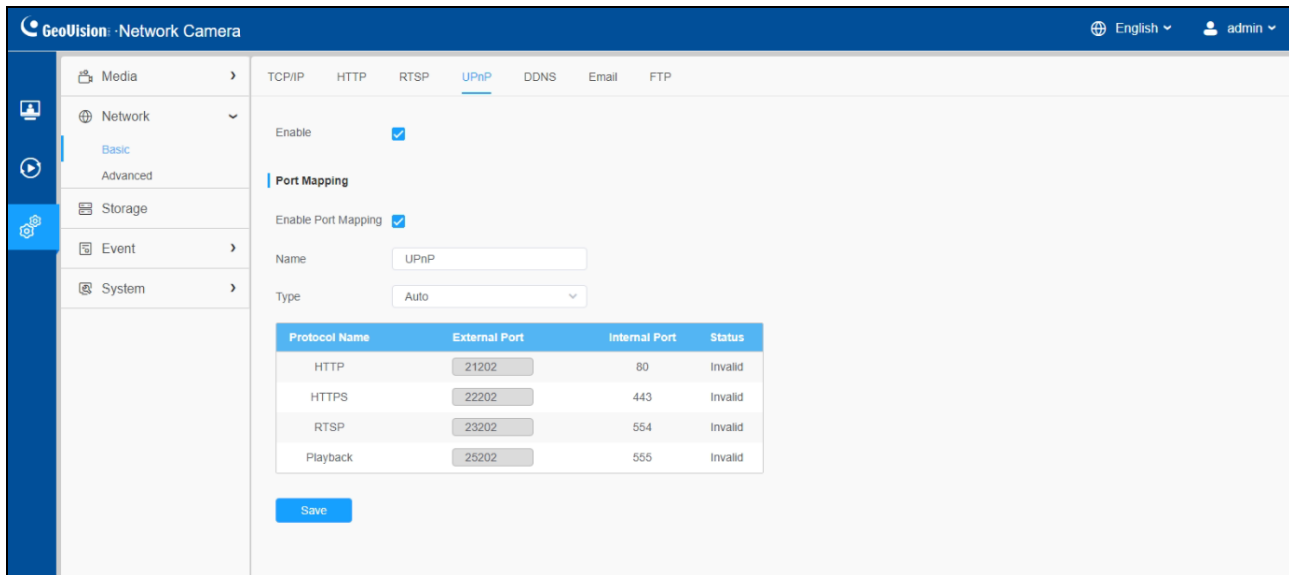
Stream	URL
<b>Primary Stream</b>	rtsp://IP:RTSP Port/main
<b>Secondary Stream</b>	rtsp://IP:RTSP Port/sub
<b>Tertiary Stream</b>	rtsp://IP:RTSP Port/third

**Note:**

- DSCP refers to the Differentiated Service Code Point; and the DSCP value is used in the IP header to indicate the priority of the data.
- A reboot is required for the settings to take effect.

### 8.2.1.4 UPnP

Universal Plug and Play (UPnP) is a networking architecture that provides compatibility among networking equipment, software and other hardware devices. The UPnP protocol allows devices to connect seamlessly and to simplify the implementation of networks in the home and corporate environments. With the function enabled, you don't need to configure the port mapping for each port, and the camera is connected to the Wide Area Network via the router.



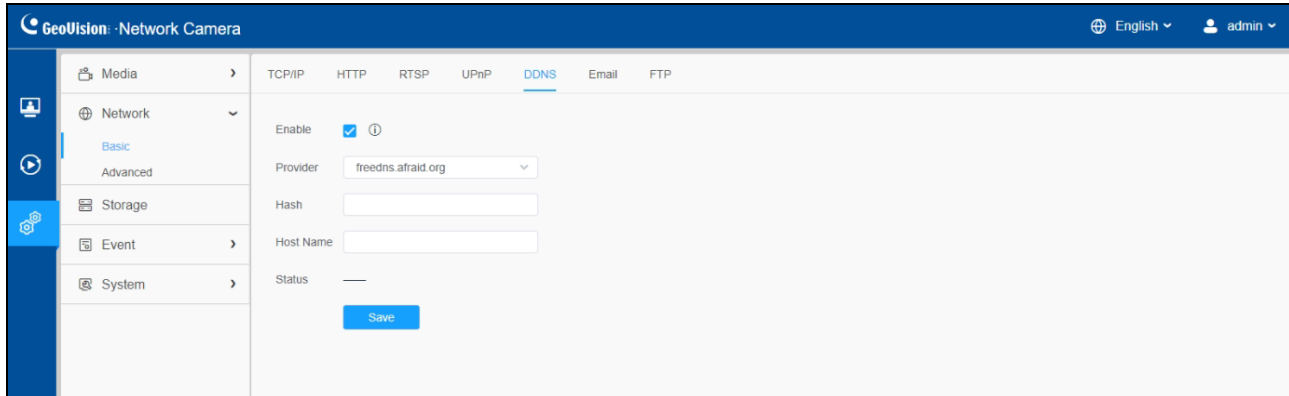
**Table 22. Description of the buttons**

Parameters	Function Introduction
<p><b>Enable</b></p>	<p>Check the checkbox to enable the UPnP function.</p>
<p><b>Port Mapping</b></p>	<p><b>Enable Port Mapping:</b> Check the checkbox to enable the Port Mapping.</p> <p><b>Name:</b> The name of the device detected online can be edited.</p> <p><b>Type:</b></p> <ul style="list-style-type: none"> <li>• <b>Auto:</b> Automatically obtain the corresponding HTTP and RTSP port, without any settings.</li> <li>• <b>Manual:</b> Need to manually set the appropriate HTTP port and RTSP Port. When choose <b>Manual</b>, you can customize the value of the port number by yourself.</li> </ul>

<input type="button" value="Save"/>	Save the configuration.
-------------------------------------	-------------------------

### 8.2.1.5 DDNS

DDNS allows you to access the camera via domain names instead of IP address. It manages to change IP address and update your domain information dynamically. You need to register an account from a provider.



For details on registering for DDNS, see *Chapter 3, GV-IP Camera User's Manual*.

**Table 23. Description of the buttons**

Parameters	Function Introduction
<b>Enable DDNS</b>	Check the checkbox to enable DDNS service. <b>Note:</b> Recommend to enable and configure UPnP ports which can be used directly in DDNS.
<b>Provider</b>	Get support from DDNS provider: freedns.org, dyndns.org, www.no-ip.com, www.zoneedit.com. You can also customize the provider for DDNS.
<b>Hash</b>	A string used for verifying, only for "freedns.afraid.org".
<b>User Name</b>	Account name from the DDNS provider, unavailable for "freedns.afraid.org".
<b>Password</b>	Account password, unavailable for "freedns.afraid.org".
<b>Host Name</b>	DDNS name enabled in the account.

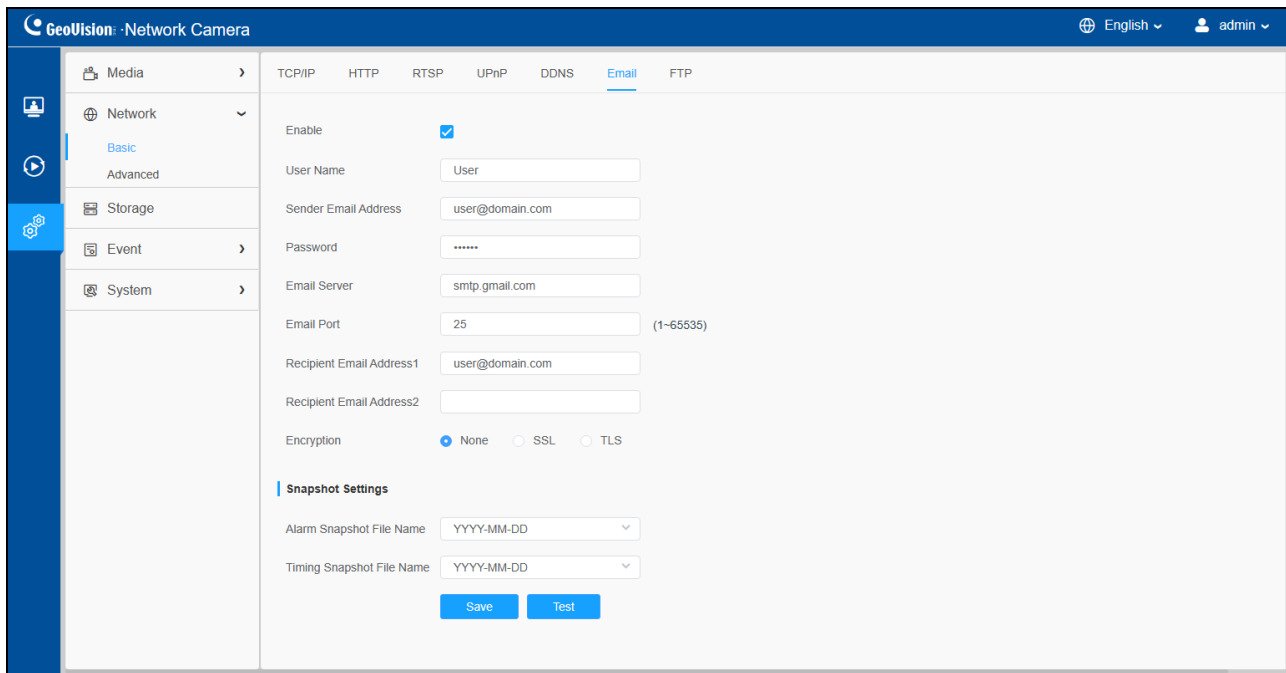
<b>Status</b>	Display DDNS running status.
<a href="#">Save</a>	Save the configuration.

**Note:**

- Make sure that the internal and the external port number of RTSP are the same.
- Please do the Port Forwarding of HTTP Port and RTSP Port before proceeding with DDNS configurations.

### 8.2.1.6 Email

Alarm video files can be sent to specific mail account through SMTP server. You must configure the email settings correctly before using it.



The screenshot shows the 'Email' configuration page in the GeoVision Network Camera web interface. The page is titled 'GeoVision - Network Camera' and includes a navigation menu on the left with options like Media, Network, Storage, Event, and System. The main content area is divided into sections for 'Email' and 'Snapshot Settings'.

**Email Configuration:**



- Enable:**
- User Name:**
- Sender Email Address:**
- Password:**
- Email Server:**
- Email Port:**  (1-65535)
- Recipient Email Address1:**
- Recipient Email Address2:**
- Encryption:**  None  SSL  TLS

**Snapshot Settings:**

- Alarm Snapshot File Name:**
- Timing Snapshot File Name:**

At the bottom of the configuration area, there are two buttons: [Save](#) and [Test](#).

**Table 24. Description of the buttons**

<b>Parameters</b>	<b>Function Introduction</b>
<b>Enable</b>	Check the checkbox to enable Email function.
<b>User Name</b>	The sender's name. It is usually the same as the account name.
<b>Sender Email Address</b>	Email address to send video files attached emails.
<b>Password</b>	The password of the sender.
<b>Email Server</b>	The email server IP address or host name.
<b>Email Port</b>	The default TCP/IP port for SMTP is 25 (not secured). For SSL/TLS port, it depends on the mail you use.
<b>Recipient Email Address1/ Recipient Email Address2</b>	Email address to receive video files.
<b>Encryption</b>	Select the options of <b>None</b> , <b>SSL</b> or <b>TLS</b> if it is required by the SMTP server.
<b>Snapshot Settings</b>	<p><b>Alarm Snapshot File Name:</b> The format of YYYY-MM-DD is set by default. Other options include MM-DD-YYYY/ DD- MM-YYYY/ Add prefix.</p> <p><b>Timing Snapshot File Name:</b> The format of YYYY-MM-DD is set by default. Other options include MM-DD-YYYY/ DD- MM-YYYY/ Add prefix.</p>
	Save the configuration.
	Test whether the configuration is successful.

**Note:** You can refer to the following file name tip to customize the file name.

File name tip

&Device – Device Name

&Y – Year

&M – Month

&D – Day

&h – hour

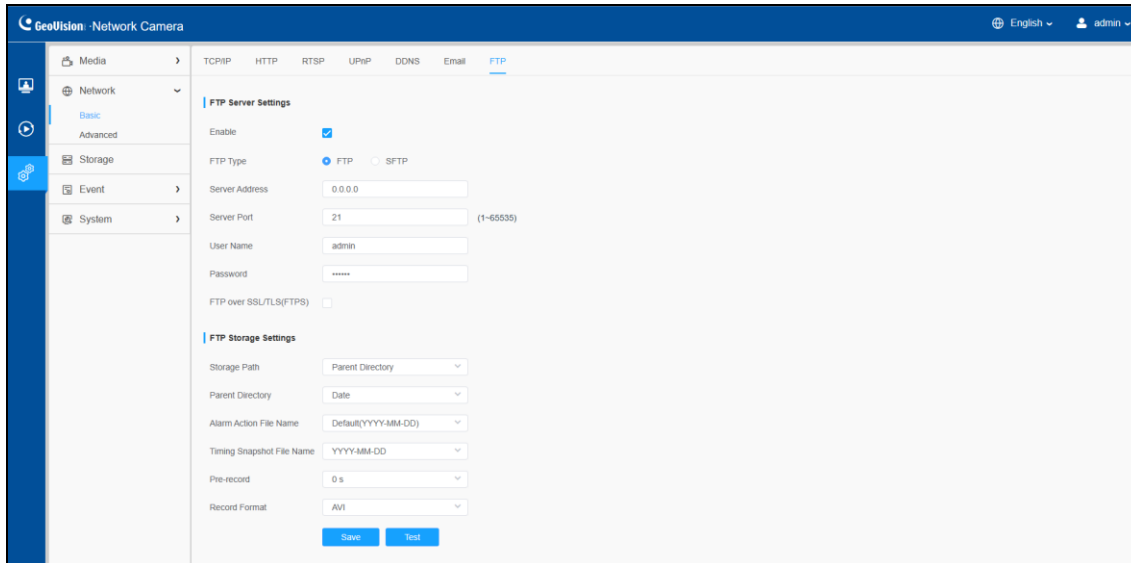
&m – minute

&s – second

&ms – millisecond

### 8.2.1.7 FTP

Alarm video files can be sent to specific FTP server. You must configure the FTP settings correctly before using it.



**Table 25. Description of the buttons**

Parameter		Function Introduction
FTP Server Settings	<b>Enable</b>	Select to enable / disable FTP server.
	<b>FTP Type</b>	<b>FTP</b> and <b>SFTP</b> are optional.
	<b>Server Address</b>	FTP/SFTP server address.
	<b>Server Port</b>	Generally, the port of the FTP server is 21, while the port of the SFTP server is 22.
	<b>User Name</b>	User name used to log in to the FTP/SFTP sever.
	<b>Password</b>	User password.
	<b>FTP over SSL/TSL (FTPS)</b>	Check the box to enable the function.
FTP Storage Settings	<b>Storage Path</b>	Storage Path where video and image will be uploaded to the FTP server. Four FTP storage path types are available, including <b>Root Directory</b> , <b>Parent Directory</b> , <b>Child Directory</b> and <b>Customize</b> .
	<b>Parent Directory</b>	Choose <b>IP Address/ Device Name/Date</b> as the folder name of Parent Directory, or customize the folder name.
	<b>Child Directory</b>	Choose <b>IP Address/ Device Name/Date</b> as the folder name of Child Directory, or customize the folder name.

<b>FTP Storage Settings</b>	<b>Multilevel Folder Name</b>	If the storage path is more than two levels, enter Multilevel FTP storage path here manually.
	<b>Alarm Action File Name</b>	Choose the default (YYYY-MM-DD) or customize the alarm action file name.
	<b>Timing Snapshot File Name</b>	Default (YYYY-MM-DD)/MM-DD-YYYY/DD-MM-YYYY/Add prefix/Overwrite with the base file name are available.
	<b>Pre-record</b>	Reserve the record time before alarm, 0~10 sec.
	<b>Record Format</b>	Choose <b>AVI / MP4</b> as the default record file format.
<input type="button" value="Save"/>	Save the configuration.	
<input type="button" value="Test"/>	Test whether the configuration is successful.	

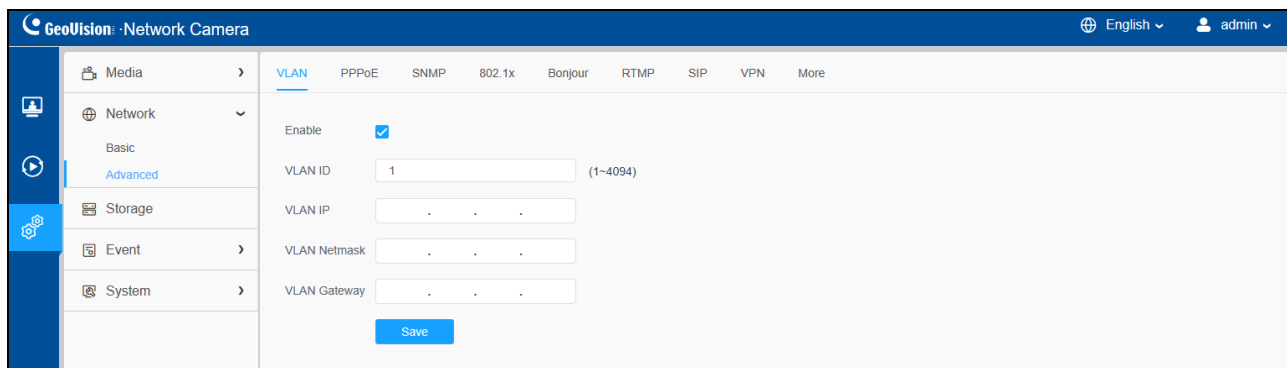
**Note:** Parent Directory will be under Root Directory, and Child Directory will be under Parent Directory.



## 8.2.2 Advanced

### 8.2.2.1 VLAN

A virtual LAN (VLAN) is any broadcast domain that is partitioned and isolated in a computer network at the data link layer (OSI layer 2). LAN is an abbreviation of local area network. VLANs allow network administrators to group hosts together even if the hosts are not on the same network switch. This can greatly simplify network design and deployment, because VLAN membership can be configured through software. Without VLANs, grouping hosts according to their resource needs necessitates the labor of relocating nodes or rewiring data links.

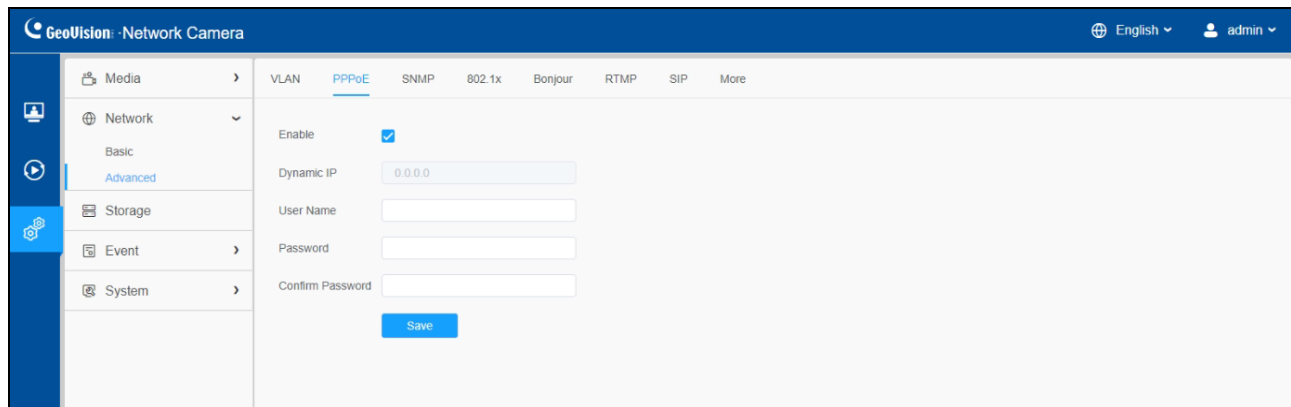


The screenshot displays the 'GeoVision Network Camera' web interface. The top navigation bar includes the logo, 'English' language selection, and 'admin' user profile. The left sidebar contains a 'Network' menu with 'Basic' and 'Advanced' sub-options. The main content area is titled 'VLAN' and features a configuration form. The 'Enable' checkbox is checked. The 'VLAN ID' field is set to '1' with a '(1~4094)' range indicator. The 'VLAN IP', 'VLAN Netmask', and 'VLAN Gateway' fields are empty. A 'Save' button is located at the bottom of the form.

**Note:** About how to set up VLAN in switches, please refers to your switches user manual.

### 8.2.2.2 PPPoE

This camera supports the PPPoE auto dial-up function. The camera gets a public IP address by ADSL dial-up after the camera is connected to a modem. You need to configure the PPPoE parameters of the network camera.



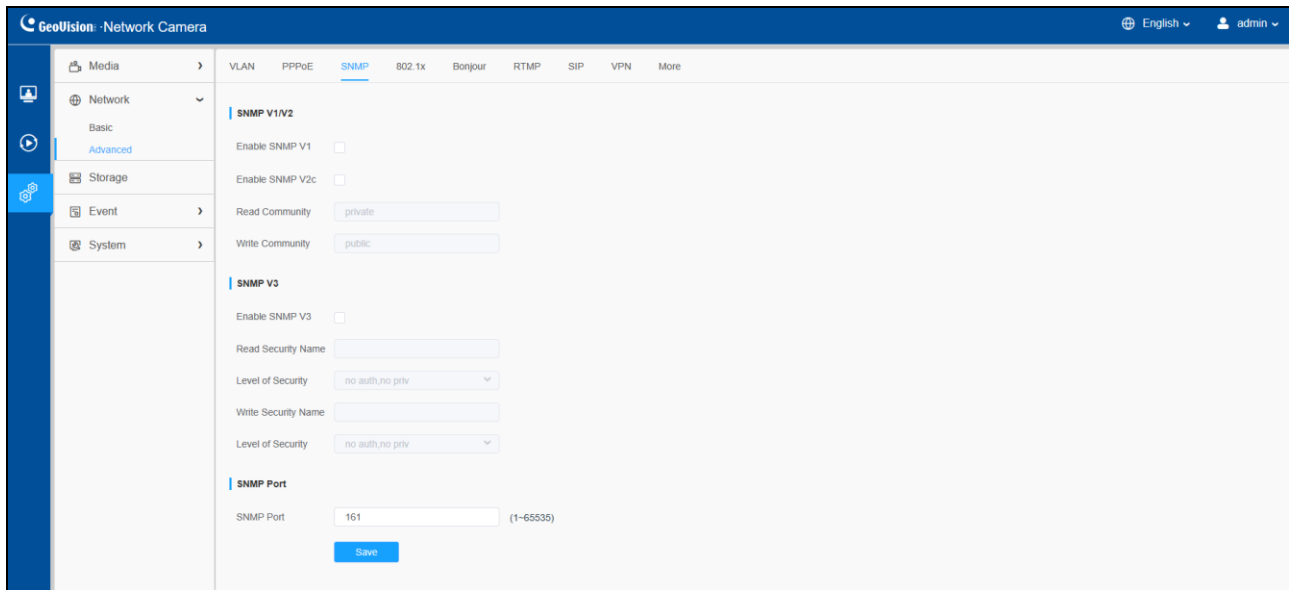
**Note:**

- The obtained IP address is dynamically assigned via PPPoE, so the IP address always changes after rebooting the camera. To solve the inconvenience of the dynamic IP, you need to get a domain name from the DDNS provider.
- The user name and password should be assigned by your ISP.

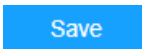
### 8.2.2.3 SNMP

You can set the SNMP function to get camera status, parameters and alarm related information and manage the camera remotely when it is connected to the network.

Before setting the SNMP, please download the SNMP software and manage to receive the camera information via SNMP port.



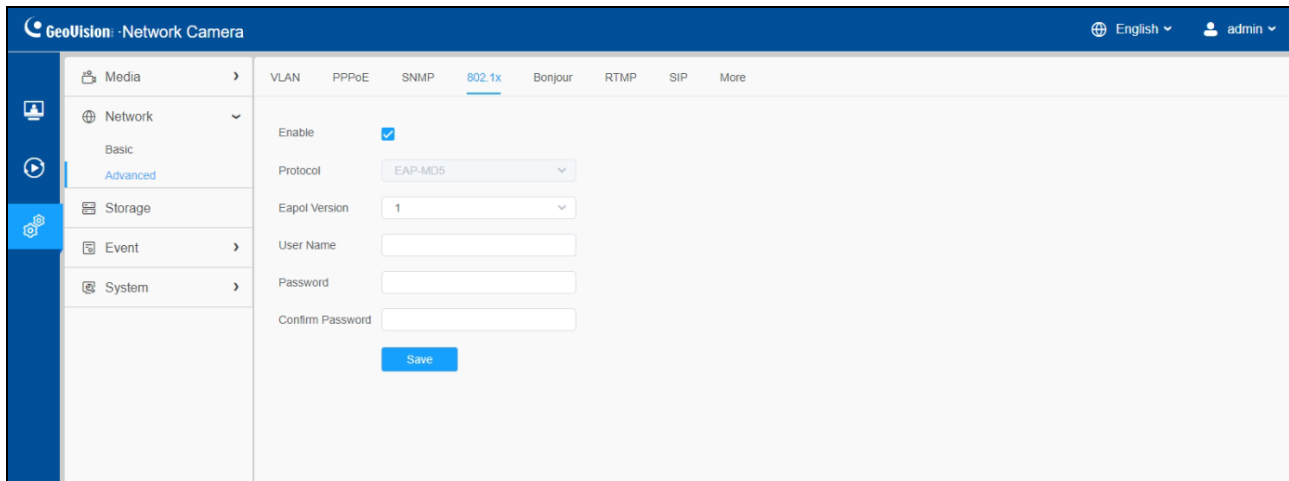
**Table 26. Description of the buttons**

Parameters	Function Introduction
<b>SNMP Port</b>	<b>The port of SNMP, the default is 161.</b>
<b>SNMP v1/v2c</b>	<p>The version of SNMP, please select the version of your SNMP software.</p> <p><b>Enable SNMP V1:</b> Provide no security.</p> <p><b>Enable SNMP V2c:</b> Require password for access.</p> <p><b>Write Community:</b> Input the name of Write Community.</p> <p><b>Read Community:</b> Input the name of Read Community.</p>
<b>SNMP v3</b>	<p><b>Enable SNMP V3:</b> Provide encryption and the HTTPS protocol must be enabled.</p> <p><b>Read Security Name:</b> Input the name of Read Security Community.</p> <p><b>Level of Security:</b> There are three levels available: (auth, priv), (auth, no priv) and (no auth, no priv).</p> <p><b>Write Security Name:</b> Input the name of Write Security Community.</p> <p><b>Level of Security:</b> There are three levels available: (auth, priv), (auth, no priv) and (no auth, no priv).</p>
<b>SNMP Port</b>	The port of SNMP, the default is 161.
	Save the configuration.

- The settings of SNMP software should be the same as the settings you configure on the web browser.
- A reboot is required for the settings to take effect.

#### 8.2.2.4 802.1x

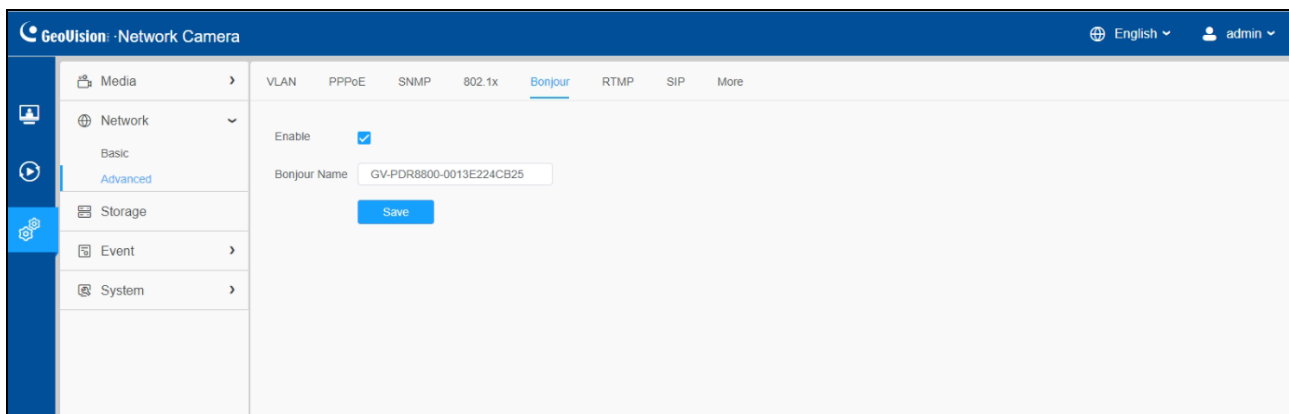
The IEEE 802.1X standard is supported by the network cameras, and when the feature is enabled, the camera data is secured and user authentication is needed when connecting the camera to the network protected by the IEEE 802.1X.



#### 8.2.2.5 Bonjour

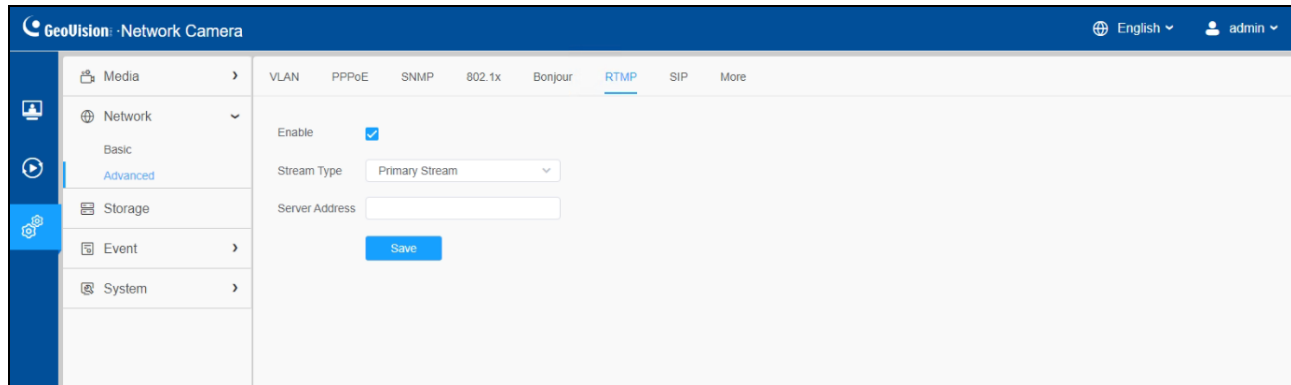
Bonjour is based on Apple's multicast DNS service. Bonjour devices can automatically broadcast their service information and listen to the service information of other devices.

If you don't know the camera information, you can use the Bonjour service on the same LAN to search for network camera devices and then to access the devices.



### 8.2.2.6 RTMP

Real-Time Messaging Protocol (RTMP) was initially a proprietary protocol for streaming audio, video and data over the Internet, between a Flash player and a server. RTMP is a TCP-based protocol which maintains persistent connections and allows low-latency communication. It can realize the function of live broadcast so that customers can log in to the camera wherever there is a network.



**Note:**

- Server Address in Network Camera RTMP interface needs to be filled with the format: `rtmp://<Server URL>/<Stream key>`. Remember it needs “/” to connect between <Server URL> and <Stream key>.

### 8.2.2.7 SIP

The Session Initiation Protocol(SIP) is a signaling communications protocol, widely used for controlling multimedia communication sessions such as voice and video calls over Internet Protocol (IP) networks. This page allows user to configure SIP related parameters. The cameras can be configured as SIP endpoint to call out when alarm triggered; or allow permitted number to call in to check the video if the video IP phone is used.

To use this function, the settings in SIP page must be configured properly. There are two ways to get video through SIP, one is to dial the IP address directly, the other is account registration mode. the details are as follows:

## Method 1: IP Direct mode

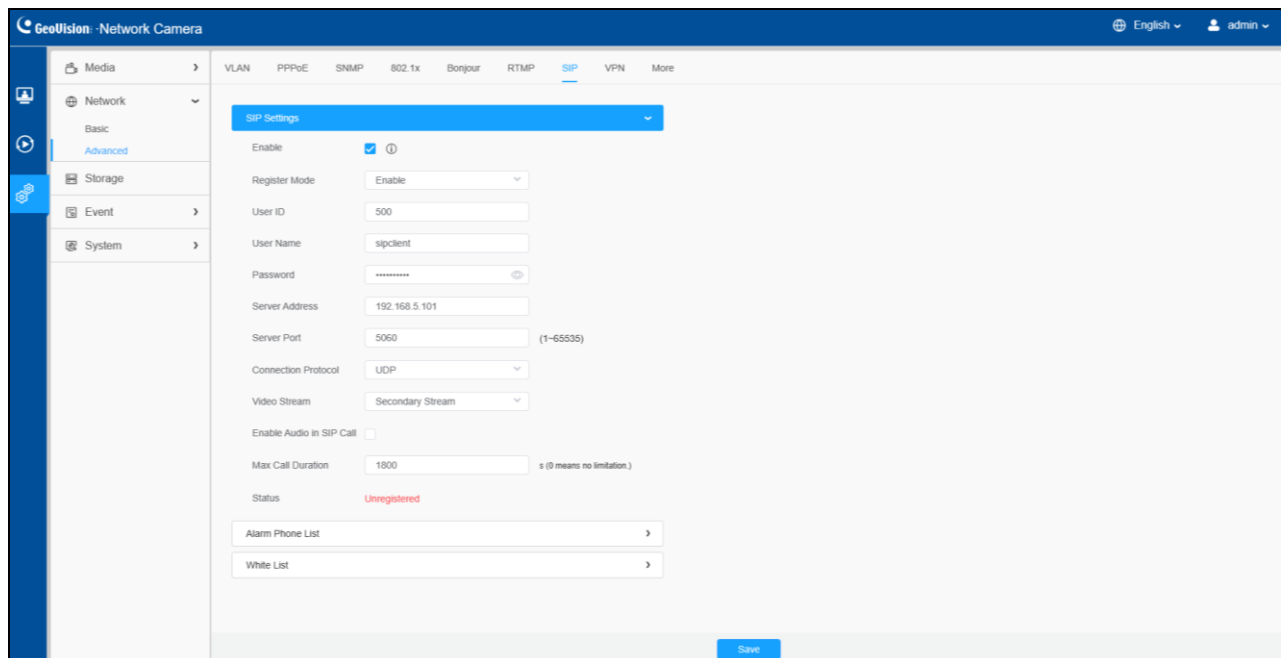
Dial on the camera's IP address directly through SIP phone, so you can see the video.

**Note:** SIP phone and the camera should be in the same network segment.

## Method 2: Account registration mode

- Before using the SIP, you need to register an account for the camera from the SIP server;
- Register another user account for the SIP device from the same SIP server;
- Call the camera User ID from the SIP device, you will get the video on the SIP device.

### [SIP Settings]



The screenshot shows the 'SIP Settings' page in the GeoVision Network Camera web interface. The page is titled 'SIP Settings' and is part of the 'SIP' configuration section. The settings are as follows:

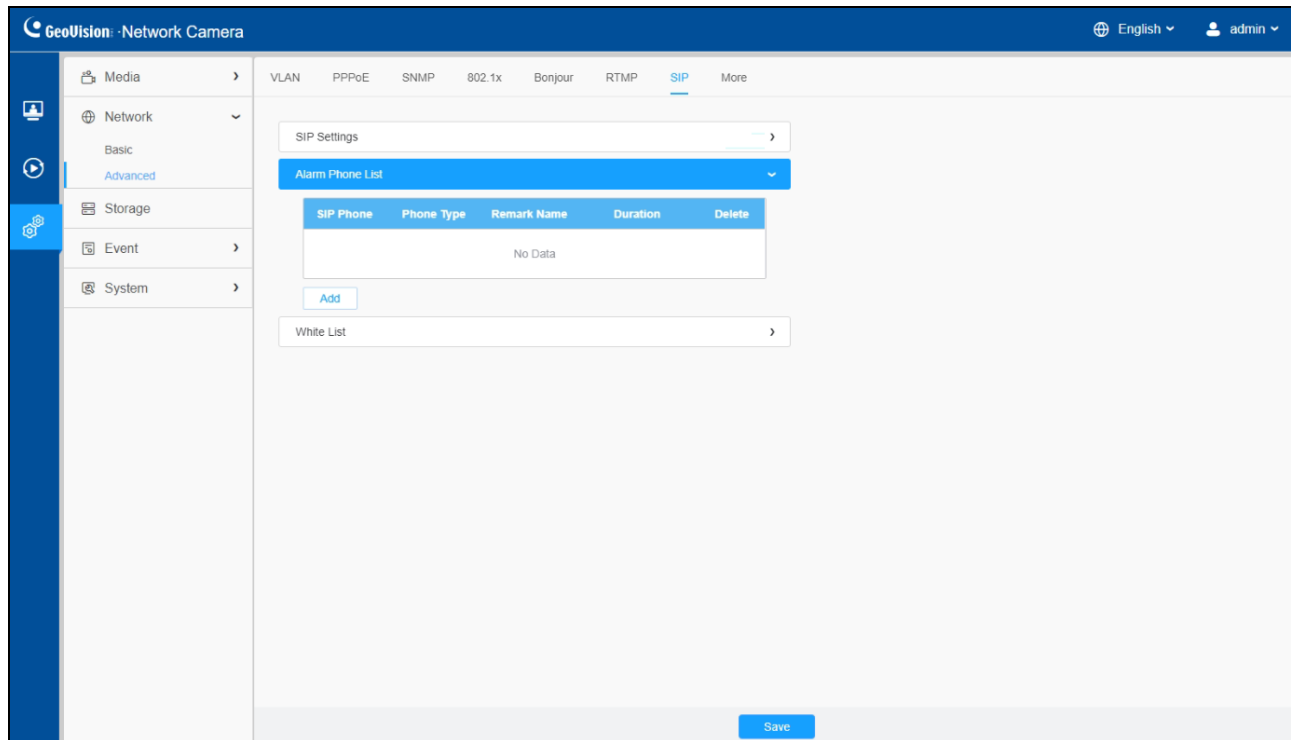
Setting	Value
Enable	<input checked="" type="checkbox"/>
Register Mode	Enable
User ID	500
User Name	sipclient
Password	*****
Server Address	192.168.5.101
Server Port	5060 (1-65535)
Connection Protocol	UDP
Video Stream	Secondary Stream
Enable Audio in SIP Call	<input type="checkbox"/>
Max Call Duration	1800 (0 means no limitation)
Status	Unregistered
Alarm Phone List	
White List	

A 'Save' button is located at the bottom right of the settings area.

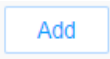

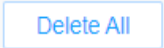
**Table 27. Description of the buttons**

Parameters	Function Introduction
<b>Enable</b>	Start or stop using SIP. <b>Note:</b> SIP supports Direct IP call.
<b>Register Mode</b>	Choose to use <b>Enable</b> mode or <b>Disable</b> mode. Enable mode means to use SIP with register account. Disable mode refers to use SIP without register account, just use the IP address to call.
<b>User ID</b>	SIP ID.
<b>User Name</b>	SIP account name.
<b>Password</b>	SIP account password.
<b>Server Address</b>	Server IP address.
<b>Server Port</b>	Server port.
<b>Connection Protocol</b>	UDP/TCP.
<b>Video Stream</b>	Choose the video stream.
<b>Enable Audio in SIP Call</b>	Enable/disable audio in SIP call.
<b>Max Call Duration</b>	The max call duration when use SIP.
<b>Status</b>	SIP registration status. Display “Unregistered” or “Registered”.

## [Alarm Phone List]

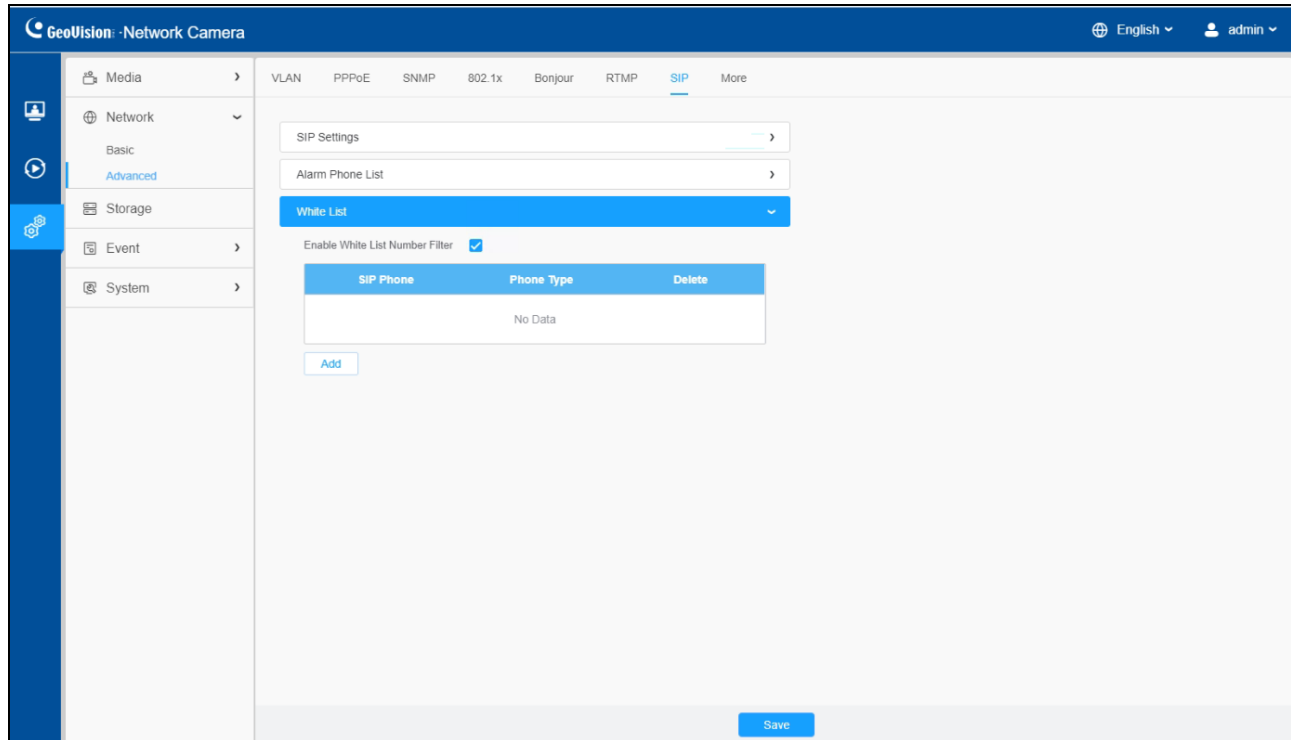


**Table 28. Description of the buttons**

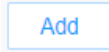
Parameters	Function Introduction
	<p>Add alarm phone to the camera.</p> <p><b>Phone Type:</b> Phone Number (Call by phone number) &amp; Direct IP Call (Check to accept peer to peer IP call).</p> <p><b>To Phone Number/IP Address:</b> Call by phone number or IP address.</p> <p><b>Remark Name:</b> Display name.</p> <p><b>Duration:</b> The time schedule to use SIP.</p>
	<p>Delete the selected alarm phone.</p>
	<p>Delete all added alarm phone.</p>



## [White List]



**Table 29. Description of the buttons**

Parameters	Function Introduction
<p><b>Enable White List Number Filter</b></p>	<p>When enabled, only the designated phone number or IP address can visit.</p>
<p></p>	<p><b>Phone Type:</b> Phone Number (Call by phone number) &amp; Direct IP Call.</p> <p><b>Phone Number/IP Address:</b> Including the phone number or IP address on the white list.</p>

## 8.2.2.8 VPN

VPN stands for Virtual Private Network. It is a network protocol that can provide you secure encrypted connection over the public Internet. It is a significant technology in surveillance industry. Imagine that you have a network camera connected via public IP address, it's possible for others to log in or listen illegally if someone knows the specific IP address and the forwarded port. Via VPN the camera streams and data will be transferred through an encrypted tunnel. This encrypted VPN tunnel makes it appear as though you are directly connected to the private network, keeping your online activity (including your browsing history) hidden. VPN feature allows users to log in the camera via a virtual IP, which makes it easier to configure the camera remotely.

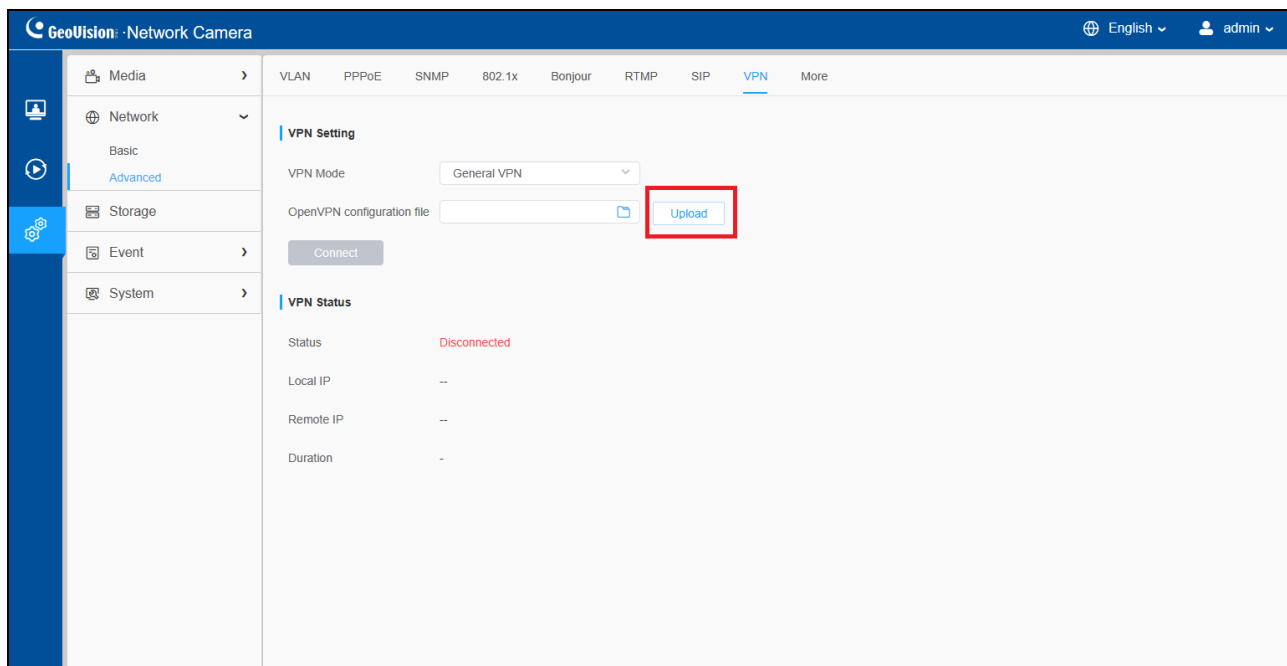
General VPN mode allows users to upload OpenVPN configuration file directly. Please note that the General VPN mode is working under OpenVPN protocol. You can take the camera as an OpenVPN client.

### Exporting an OpenVPN configuration file

First we need to prepare an OpenVPN configuration file. Configuration file (also known as connection profile) is an .ovpn text file that contains the directives, parameters, and certificates required to establish the server-client connection. Refer to the official instruction regarding the configuration file exporting: <https://openvpn.net/vpn-server-resources/create-connection-profiles-and-connect-client-installers/>

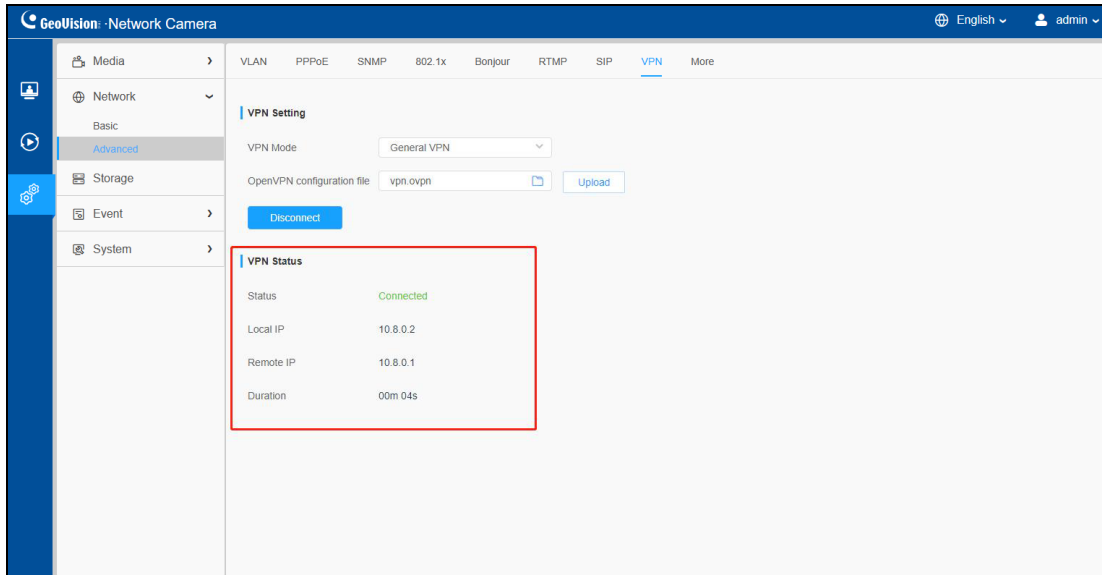
### Uploading the OpenVPN configuration file

Next, we need to upload the configuration file. The connection will start automatically once the uploading is done:



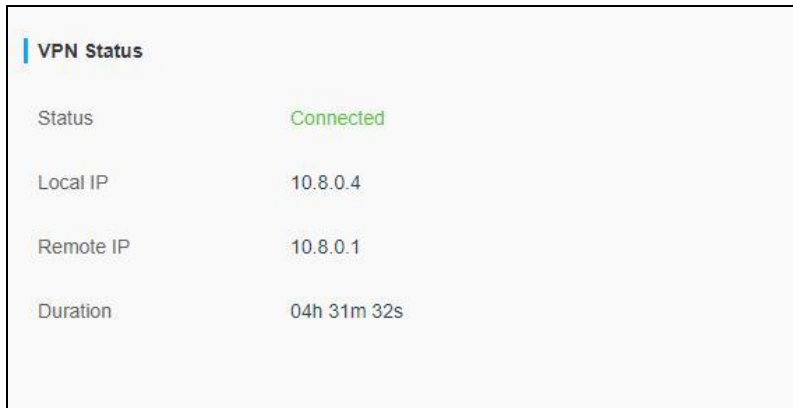
**Note:** If you disconnect the VPN manually or the connection is broken due to network error, to restore connection you need to upload the configuration file on this page again.

Check the connection status. The picture below shows a normal connection status:



### Connecting camera via VPN on the web browser

After the VPN connection is established, we can log in the camera via virtual IP address.

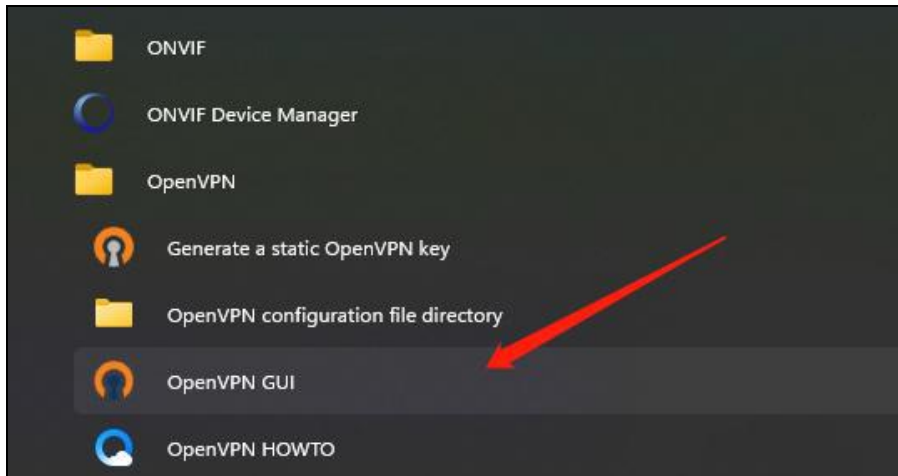


Parameters	Definition
Status	Status of VPN connection
Local IP	Camera virtual IP
Remote IP	VPN virtual IP
Duration	Connection duration

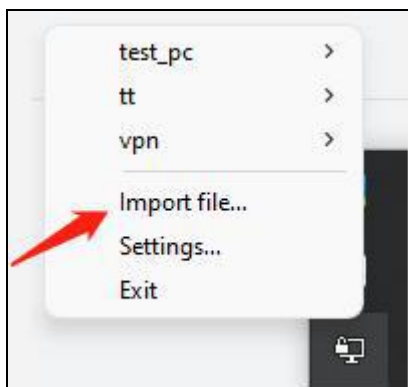
## Connecting camera via VPN on OpenVPN application

Optionally, you can also connect the camera via VPN on OpenVPN application. First please make sure your computer is also connected to VPN. For example, you can download OpenVPN client for Windows from: <https://openvpn.net/client-connect-vpn-for-windows/>

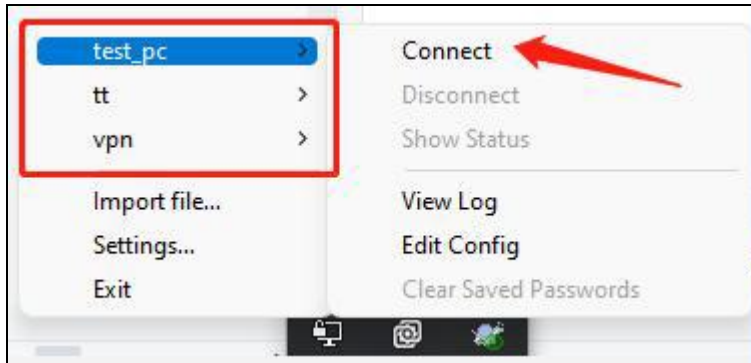
After installation, you can see the application in Start menu. Open the app:



Right click the VPN connection icon on tool bar and select *Import file*. Please prepare another OpenVPN configuration file that is different from camera's.



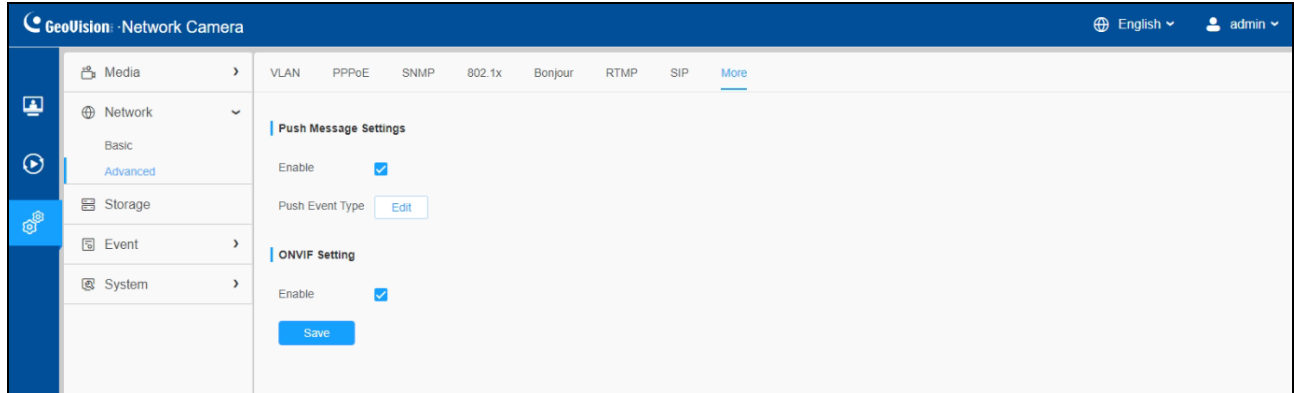
In this area, you can see all the configuration file you've uploaded. Select the corresponding file to connect:




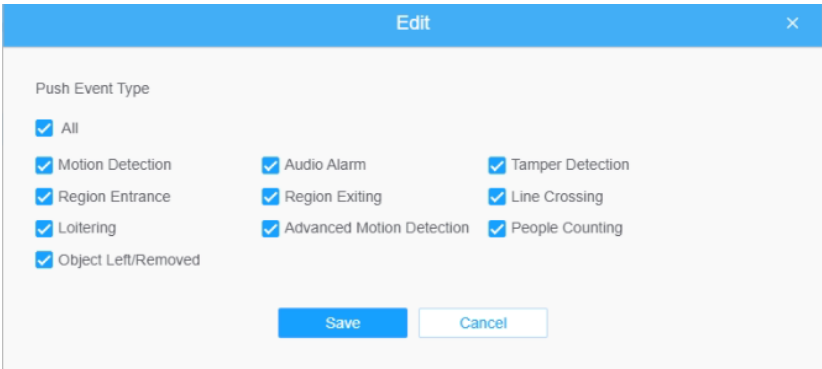
When the connection is done, your computer will show this icon:  Open the Web browser and enter virtual IP address to log in the camera via Web.

### 8.2.2.9 More

Here you can set more functions, like Push Message Settings and ONVIF Settings. Note that Push Message is currently not functional.

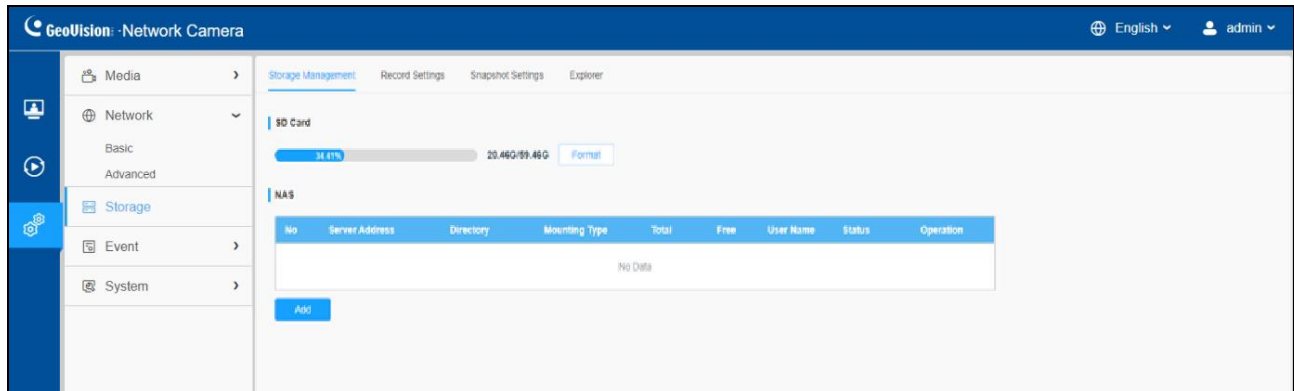


**Table 30. Description of the buttons**

Parameters	Function Introduction
<p><b>Push Message Settings</b></p>	<p><b>Enable:</b> Enable/disable the Push Message function.</p> <p><b>Push Event Type:</b> You can click  to choose the types of Event message as shown below:</p> 
<p><b>ONVIF Setting</b></p>	<p>Here you can choose whether to enable or disable camera ONVIF function. If camera ONVIF function is enabled, it can be searched out, added and connected by third-party software through ONVIF protocols. Generally, the default status of ONVIF function is enabled.</p>

## 8.3 Storage

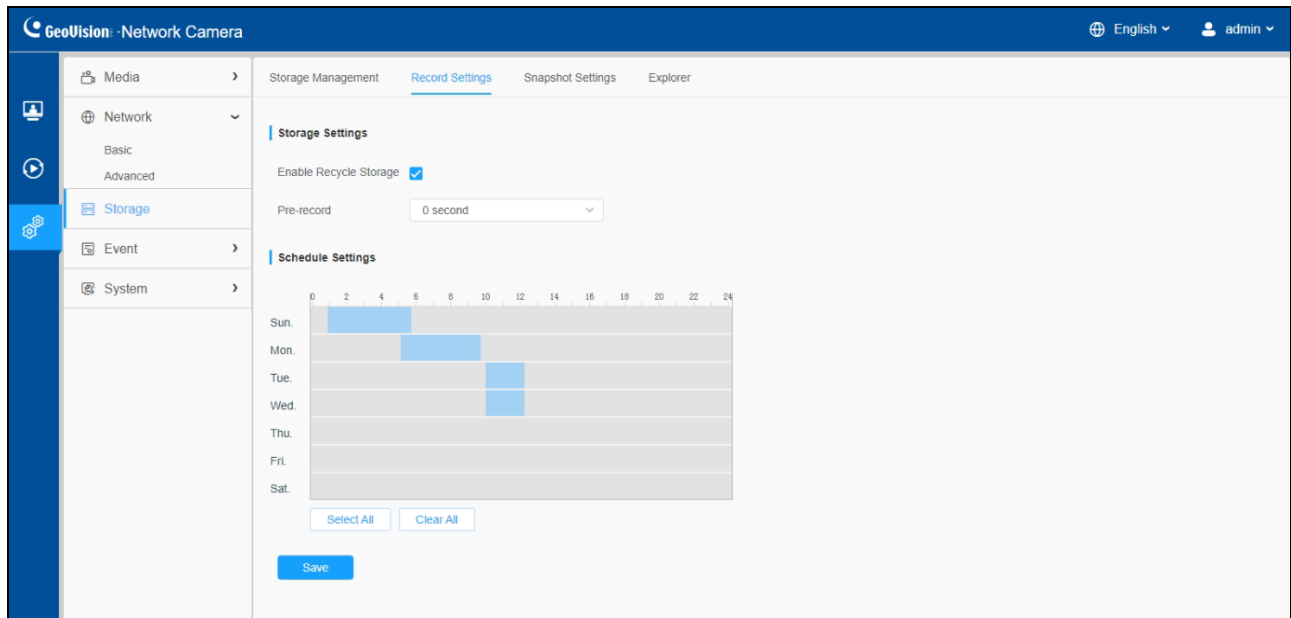
### 8.3.1 Storage Management



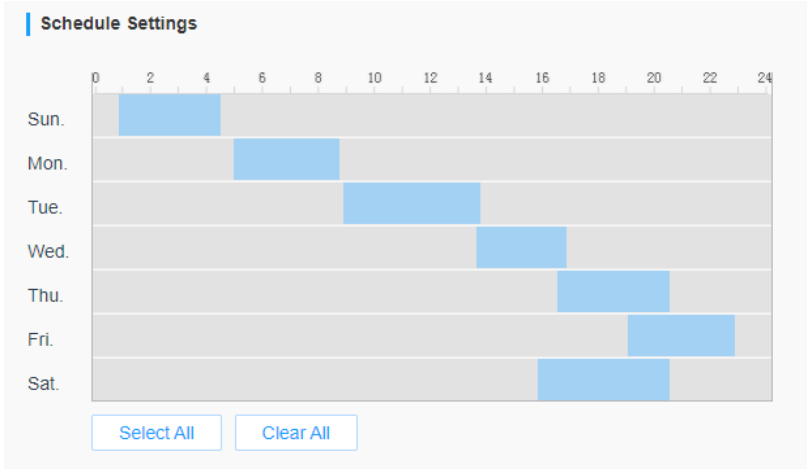
**Table 31. Description of the buttons**

Parameters	Function Introduction
SD Card	<b>Format:</b> Format SD card, the files in SD card will be removed.
NAS	<p>The network disk should be available within the network and properly configured to store the recorded files, etc.</p> <p>NAS (Network-Attached Storage), connecting the storage devices to the existing network, provides data and files services.</p> <p><b>Server Address:</b> IP address of NAS server.</p> <p><b>Directory:</b> Input the NAS directory, e.g. “\path”.</p> <p><b>Mounting Type:</b> NFS and SMB/CIFS are available. You can set the user name and password to guarantee the security if SMB/CIFS is selected.</p> <p><b>Note:</b> Up to 5 NAS disks can be connected to the camera.</p>

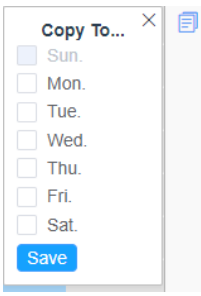
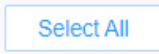
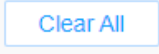

## 8.3.2 Record Settings



**Table 32. Description of the buttons**

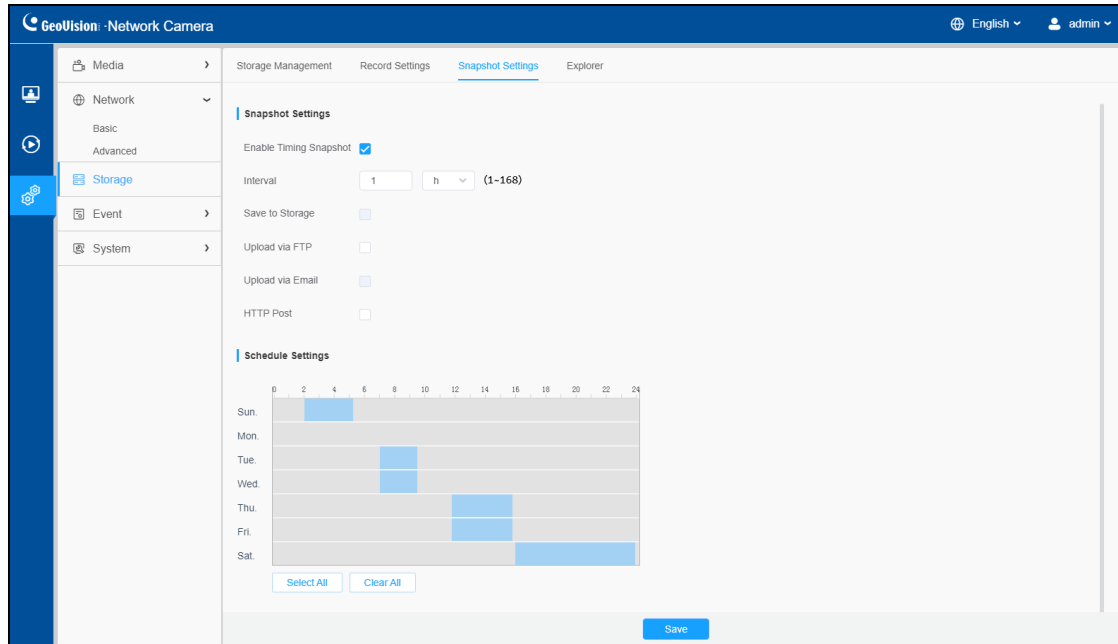
Parameters	Function Introduction
<b>Enable Recycle Storage</b>	Enable/Disable Recycle Storage. If you enable this option, it will delete the files when the free disk space reaches a certain value.
<b>Pre Second</b>	Reserve the record time before alarm, 0~10 sec.
<b>Schedule Settings</b>	Edit record schedule as needed. Intuitive scheduling by drawing the time bar directly. <div data-bbox="472 1396 1273 1864" style="border: 1px solid #ccc; padding: 5px; margin-top: 10px;"> <p><b>Schedule Settings</b></p>  </div>



<b>Schedule Settings</b>		Copy the schedule area to another date.
		Select all schedule.
		Clear all schedule.
	Save the configuration.	

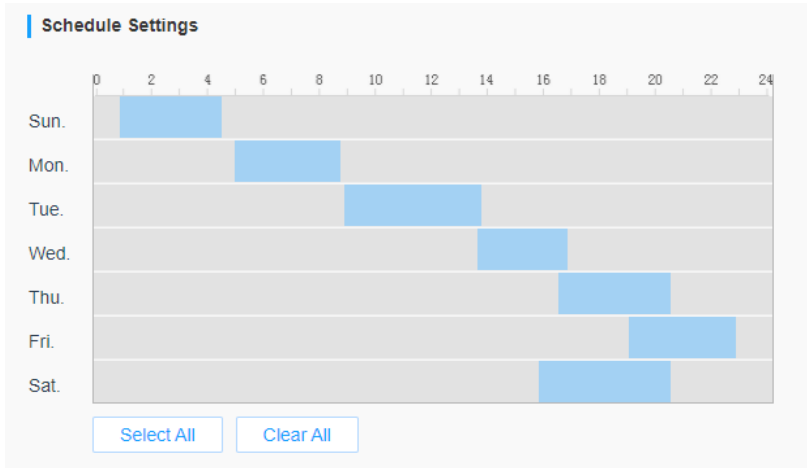
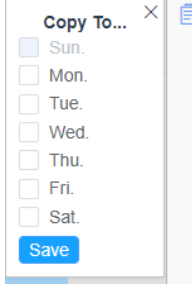
**Note:** SD Card or NAS are available.

### 8.3.3 Snapshot Settings



**Table 33. Description of the buttons**

Parameters	Function Introduction
<p style="text-align: center;"><b>Snapshot Settings</b></p>	<p><b>Enable Timing Snapshot:</b> Check the checkbox to enable the Timing Snapshot function.</p> <p><b>Interval:</b> Set the snapshots interval, input the number and choose the unit (millisecond, second, minute, hour, day).</p> <p><b>Save To Storage:</b> Save the snapshots to SD card or NAS, and choose the file name to add time suffix or overwrite the base file name.</p> <p><b>Save Into NAS:</b> Save the snapshots to NAS, and choose the file name to add time suffix or overwrite the base file name.</p> <p><b>Upload Via FTP:</b> Upload the snapshots via FTP.</p> <p><b>Upload Via Email:</b> Upload the snapshots via Email.</p> <p><b>Note:</b> If you choose to add time suffix, every snapshot picture will be saved, but if you choose to overwrite the base file name, only the latest picture will be saved. When you choose Overwrite the Base File Name and save it to SD Card or NAS, it will create a file named "Snapshot" to place the snapshot.</p> <p><b>HTTP Post:</b> Upload the snapshots via HTTP Post. Support uploading the snapshots to specified HTTP URL.</p>

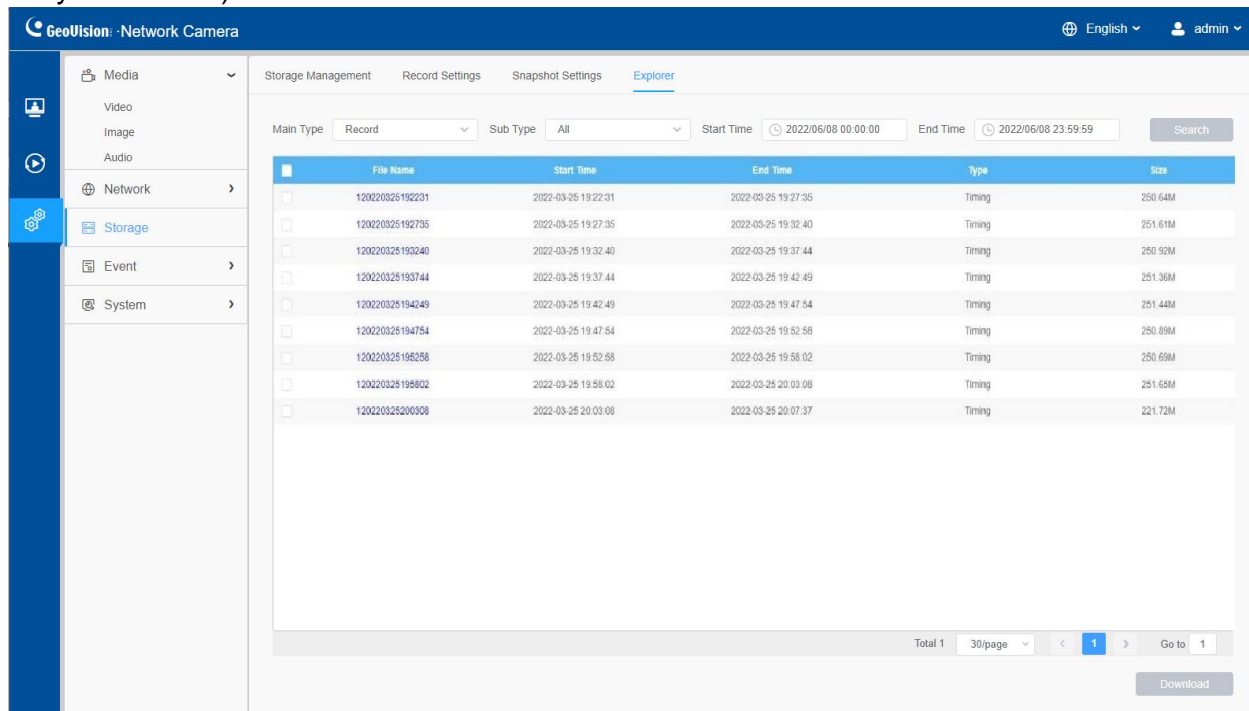
<p><b>Schedule Settings</b></p>	<p>Edit record schedule as needed. Intuitive scheduling by drawing the time bar directly.</p> 
<p><b>Schedule Settings</b></p>	<p>Copy the schedule area to another date.</p> 
<p><b>Schedule Settings</b></p>	<p>Select all schedule.</p>
<p><b>Schedule Settings</b></p>	<p>Clear all schedule.</p>
<p><b>Save</b></p>	<p>Save the configuration.</p>

## 8.3.4 Explorer

Files will be seen on this page when they are configured to save into SD card or NAS. You can set time schedule every day for recording videos and save video files to your desired location.

**Note:** Files are visible once SD card is inserted. Don't insert or pull out SD card when power on.

Video files are arranged by date. Set file type and start/end time to search out files. Each day files will be displayed under the corresponding date, from here you can copy and delete files etc. You can visit the files in SD card by ftp, for example, <ftp://username:password@IP> (the default user name is admin and the IP followed is the IP of your device.).



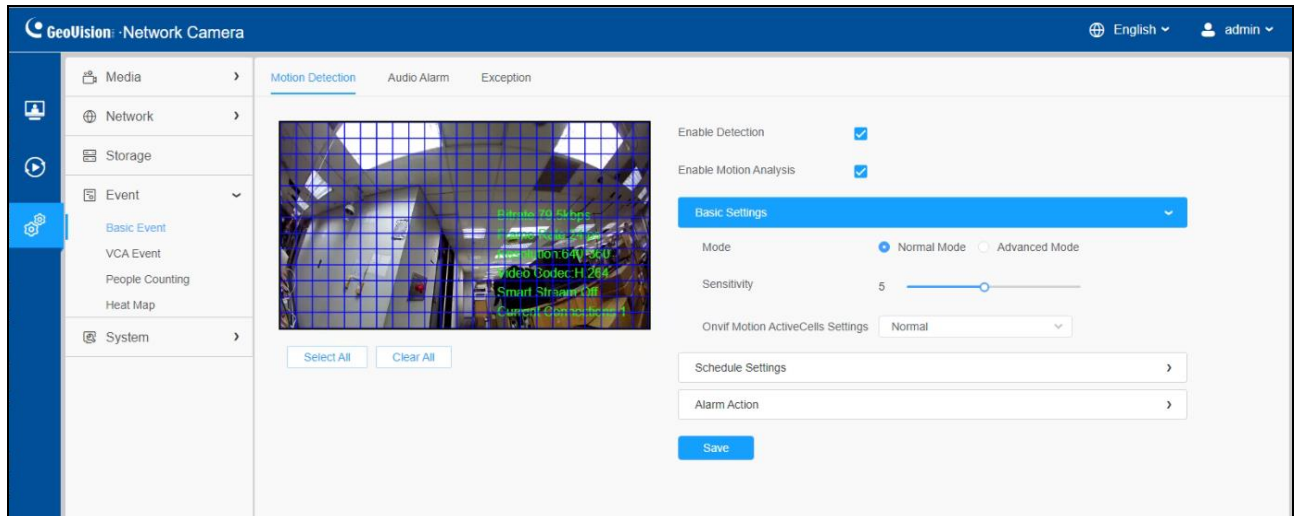
The screenshot shows the 'Explorer' tab in the GeoVision Network Camera web interface. The interface includes a left sidebar with navigation options: Media (Video, Image, Audio), Network, Storage (selected), Event, and System. The main content area displays a table of recorded files with the following columns: File Name, Start Time, End Time, Type, and Size. The table contains 10 rows of data, all of which are 'Timing' type files recorded on 2022-03-25. Below the table, there is a pagination control showing 'Total 1' and '30/page', and a 'Download' button.

File Name	Start Time	End Time	Type	Size
120220325192231	2022-03-25 19:22:31	2022-03-25 19:27:35	Timing	250.64M
120220325192735	2022-03-25 19:27:35	2022-03-25 19:32:40	Timing	251.61M
120220325193240	2022-03-25 19:32:40	2022-03-25 19:37:44	Timing	250.92M
120220325193744	2022-03-25 19:37:44	2022-03-25 19:42:49	Timing	251.38M
120220325194249	2022-03-25 19:42:49	2022-03-25 19:47:54	Timing	251.44M
120220325194754	2022-03-25 19:47:54	2022-03-25 19:52:58	Timing	250.89M
120220325195258	2022-03-25 19:52:58	2022-03-25 19:58:02	Timing	250.69M
120220325195802	2022-03-25 19:58:02	2022-03-25 20:03:08	Timing	251.65M
120220325200308	2022-03-25 20:03:08	2022-03-25 20:07:37	Timing	221.72M

## 8.4 Event

### 8.4.1 Basic Event

#### 8.4.1.1 Motion Detection



Settings steps are shown as follows:


**Step 1:** Check the checkbox to enable the motion detection.

**Step 2:** Check the check box to enable the motion analysis.

**Step 3:** Select the detection mode.

**Step 4:** Set motion region.

**Table 34. Description of the buttons**

Parameters	Function Introduction
<p><b>Enable Detection</b></p>	<p>Check the checkbox to enable <b>Motion Detection</b> function.</p>
<p><b>Enable Motion Analysis</b></p>	<p>When <b>Motion Analysis</b> is enabled, the moving region will turn yellow so that the user can know exactly where the motion occurred.</p> <p><b>Note:</b> Only support when HTTP is selected in Live View.</p> 
<p>Select All</p>	<p>Click the button, the motion in the area will be detected.</p>
<p>Clear All</p>	<p>Click the button, the area drawn before will be removed.</p>
<p>Save</p>	<p>Save the configuration.</p>

**[Basic Settings]**

Enable Detection

Enable Motion Analysis

**Basic Settings** ▾

Mode  Normal Mode  Advanced Mode

Sensitivity 9

Onvif Motion ActiveCells Settings Normal ▾

Schedule Settings >

Alarm Action >

Save

**Table 35. Description of the buttons**

Parameters	Function Introduction
<b>Detection Mode</b>	<b>Normal Mode</b> and <b>Advanced Mode</b> are available for the option. When <b>Advanced Mode</b> is selected, users can configure up to 4 detection regions and sensitivity for each detection region.
<b>Sensitivity</b>	Sensitivity level, 1~10.
<b>Onvif Motion ActiveCells Settings</b>	<b>Normal</b> and <b>Compatible</b> are available for the option. If the setting of motion region of the third-party software is different from the camera's, please set this option to <b>Compatible</b> .

**[Schedule Settings]**

**Step 5:** Set motion detection schedule.

Enable Detection

Enable Motion Analysis

Basic Settings >

Schedule Settings v

0 2 4 6 8 10 12 14 16 18 20 22 24

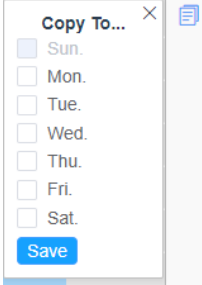
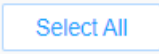
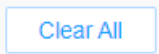
Sun.	
Mon.	
Tue.	
Wed.	
Thu.	
Fri.	
Sat.	

Select All
Clear All

Alarm Action >

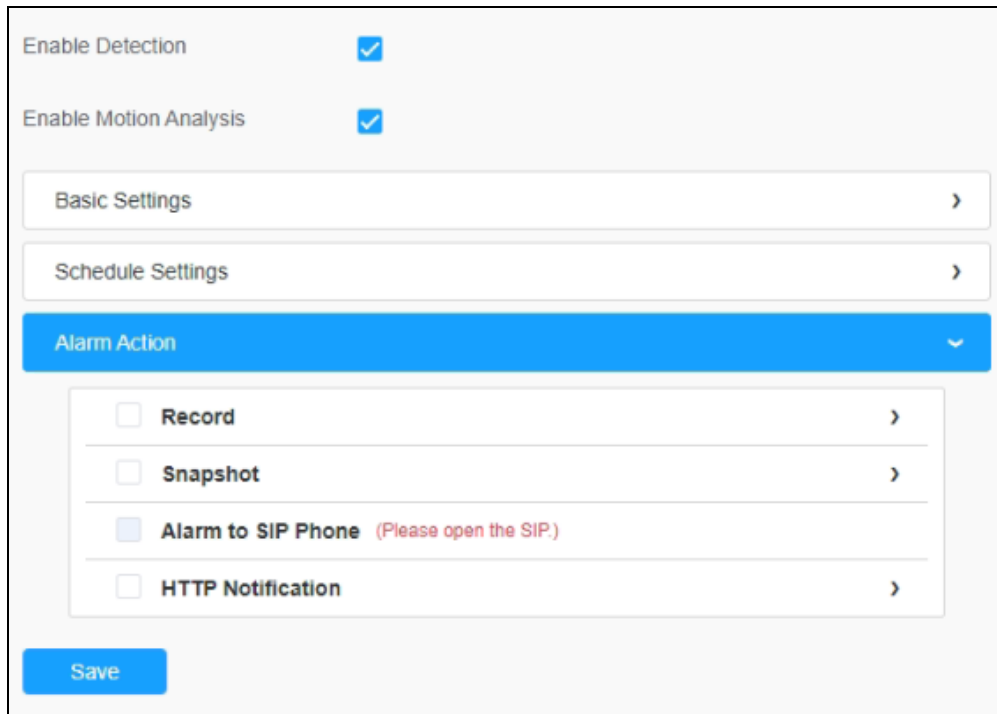
Save

**Table 36. Description of the buttons**

Parameters	Function Introduction
	Copy the schedule area to another date.
	Select all schedule.
	Clear all schedule.

**[Alarm Action]**

**Step 6:** Set alarm action.



Enable Detection

Enable Motion Analysis

Basic Settings >

Schedule Settings >

**Alarm Action** ▾

Record >

Snapshot >


Alarm to SIP Phone (Please open the SIP.)

HTTP Notification >

Save



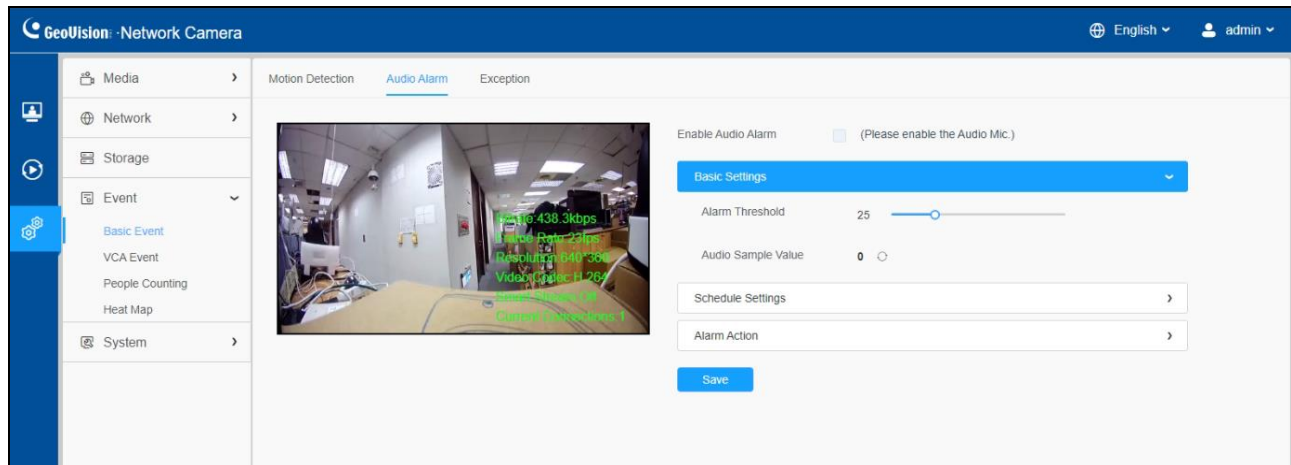
**Table 37. Description of the buttons**

Parameters	Function Introduction
<p align="center"><b>Record</b></p>	<p><b>Duration:</b> Selected the duration time of alarm. <b>5 s/10 s/15 s/20 s/25 s/30 s</b> are available.</p> <p><b>Linkage:</b> Save alarm recording files to SD Card or NAS or upload the recording files via FTP.</p>
<p align="center"><b>Snapshot</b></p>	<p><b>Number:</b> The number of snapshots, 1~5 are available.</p> <p><b>Interval:</b> This cannot be edited unless you choose more than 1 to <b>Snapshot</b>.</p> <p><b>Linkage:</b> Save alarm recording files to SD Card or NAS, upload the recording files via FTP, or send alarm emails.</p>
<p align="center"><b>Alarm to SIP Phone</b></p>	<p>Support to call the SIP phone after enable the SIP function.</p>
<p align="center"><b>HTTP Notification</b></p>	<p>Support to pop up the alarm news to specified HTTP URL.</p> <p> <b>Note:</b></p> <ul style="list-style-type: none"> <li>• Three HTTP notifications at most can be added to the same event.</li> <li>• HTTP Notification supports Basic &amp; Digest authentication.</li> </ul>

#### 8.4.1.2 Audio Alarm

Check the check box to enable the **Audio Alarm** function.

**Note:** Enable the Audio Mic before using Audio Alarm function.



### [Basic Settings]

**Table 38. Description of the buttons**

Parameters	Function Introduction
<b>Alarm Threshold</b>	Audio Alarm will be triggered when the thresholds reach to a certain value from 0 to 100.
<b>Audio Sample Value</b>	The current value of the audio sample.

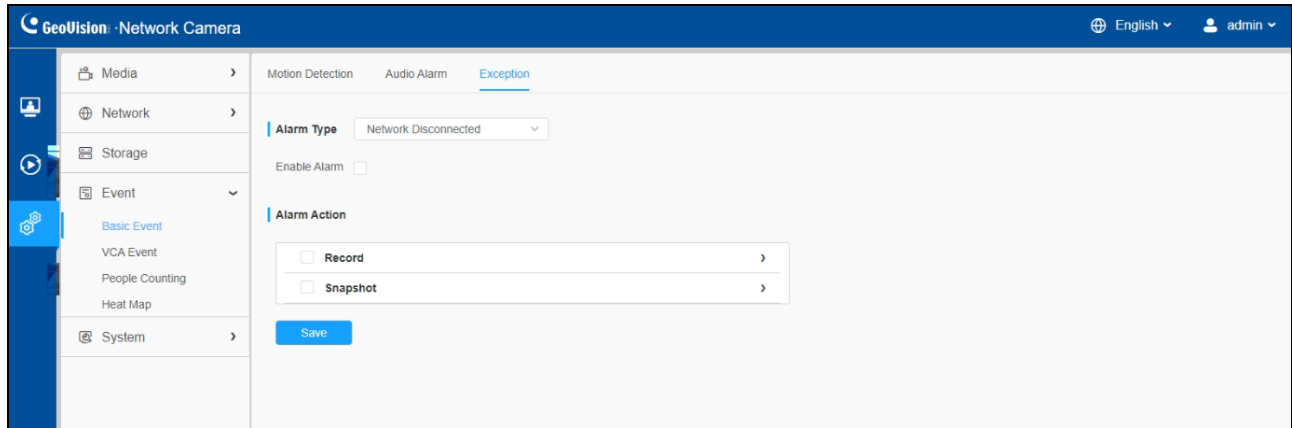
### [Schedule Settings]

Refer to *Table 36 of 8.4.1.1 Motion* for details.

### [Alarm Action]

Refer to *Table 37 of 8.4.1.1 Motion* for details.

### 8.4.1.3 Exception



**Table 39. Description of the buttons**

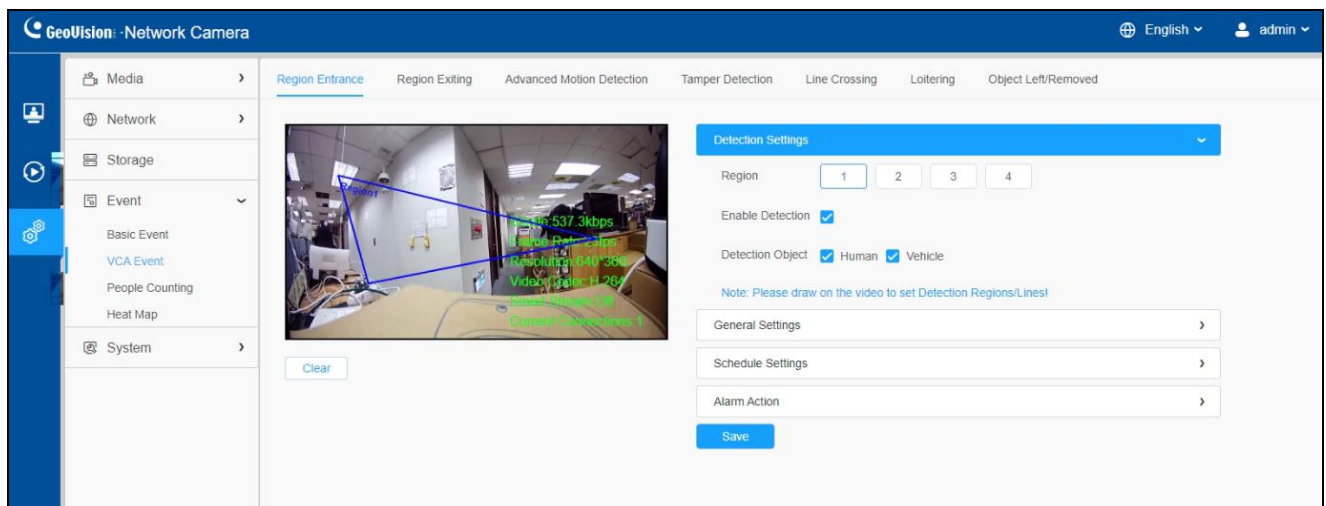
Parameters	Function Introduction
<p><b>Alarm Type</b></p>	<p><b>Network Disconnected, IP Address Conflicted, Record Failed, SD Card Full, SD Card Uninitialized, SD Card Error and No SD Card</b> are available.</p> <p>Check the checkbox to enable the alarm type you selected</p>
<p><b>Alarm Action</b></p>	<p><i>Refer to Table 37 of 8.4.1.1 Motion for details.</i></p>

## 8.4.2 VCA Event

Smart Event uses VCA (Video Content Analysis) technology, which provides advanced, accurate smart video analysis. Powered by AI chip, the new generation video analytics is capable of recognizing vast attributes of human, vehicle, and object pattern recognition models. As vehicle and human related events are very important in security monitoring, the filtering is supported to better optimize the efficiency.

### 8.4.2.1 Region Entrance

Region entrance helps to protect a special area from potential threat of suspicious person's or object's entrance. An alarm will be triggered when objects enter the selected regions by enabling region entrance.



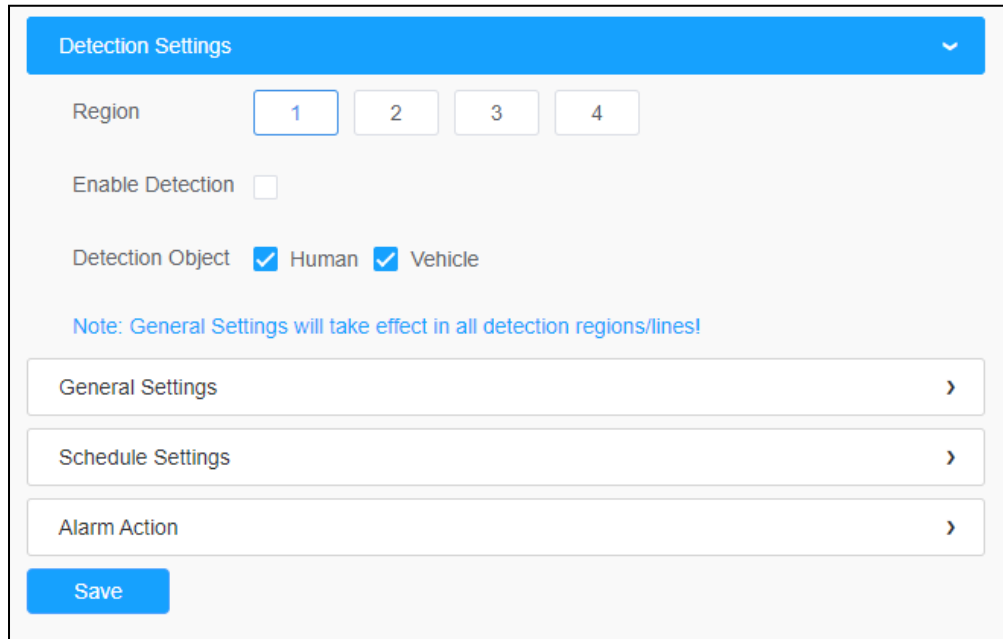
Settings steps are shown as follows:

#### [Detection Settings]

**Note:** General Settings will take effect in all detection regions/lines!

**Step 1:** Selected Detection Region and enable region entrance detection;

**Step 2:** Choose detection object. Check **Human** or **Vehicle** attribute, and the camera will alarm once detecting people or vehicle and triggering related events;



Detection Settings

Region

Enable Detection

Detection Object  Human  Vehicle

Note: General Settings will take effect in all detection regions/lines!

General Settings >

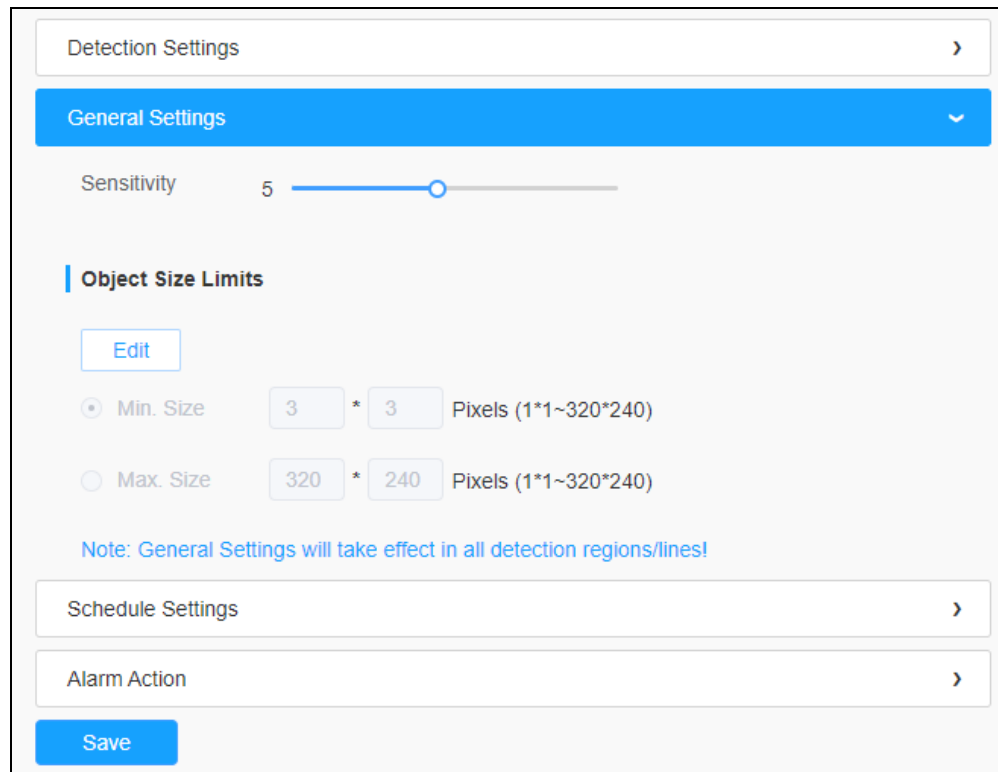
Schedule Settings >

Alarm Action >

Save

### [General Settings]

**Step 3:** Set detecting sensitivity and object size limits;



Detection Settings >

General Settings

Sensitivity 5

**Object Size Limits**

Edit

Min. Size  \*  Pixels (1\*1~320\*240)

Max. Size  \*  Pixels (1\*1~320\*240)

Note: General Settings will take effect in all detection regions/lines!

Schedule Settings >

Alarm Action >

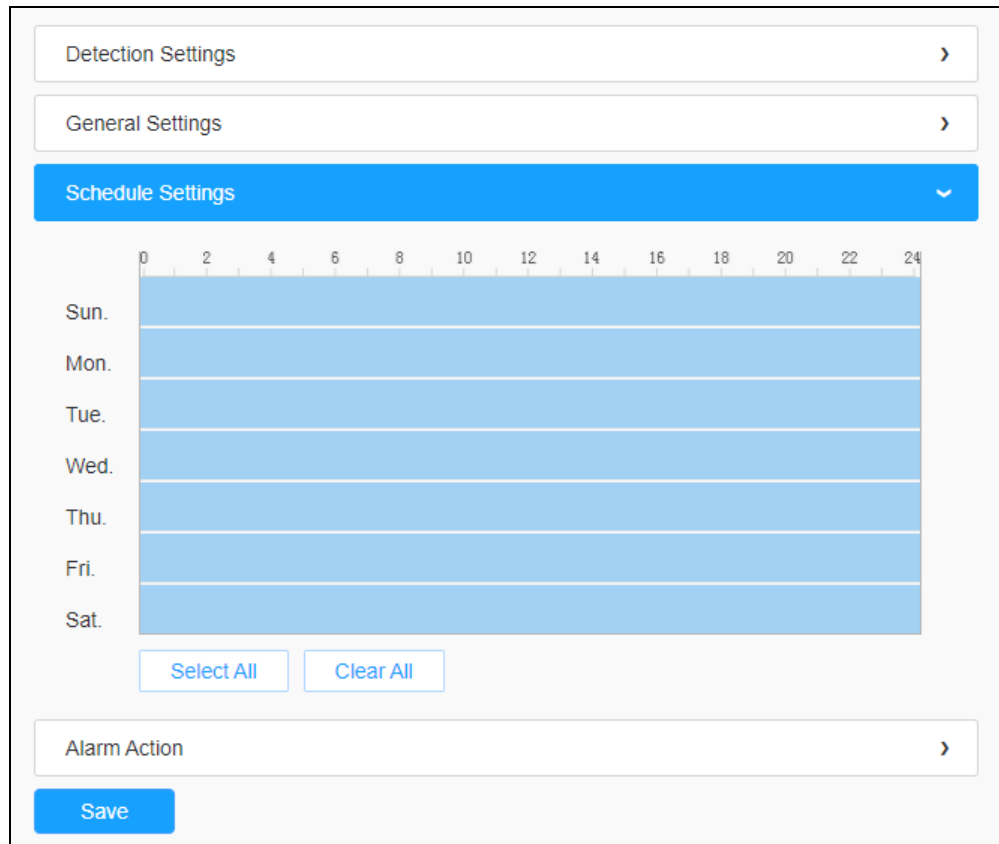
Save

**Table 40. Description of the buttons**

Parameters	Function Introduction
<b>Sensitivity</b>	Level 1~10 is available, the default level is 5. The higher the sensitivity, the easier it is for moving objects to be recorded in the results.
<b>Min. Size</b>	Draw the screen or input pixel number to set the minimum size of the detected object. When the object is smaller than this size, it will not be detected. The default minimum size is 3*3.
<b>Max. Size</b>	Draw the screen or input pixel number to set the maximum size of the detected object. When the object is larger than this size, it will not be detected. The default maximum size is 320*240.

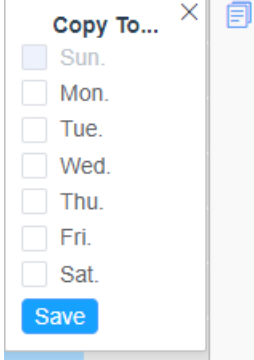
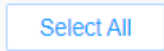

**[Schedule Settings]**

**Step 4:** Set detection schedule;



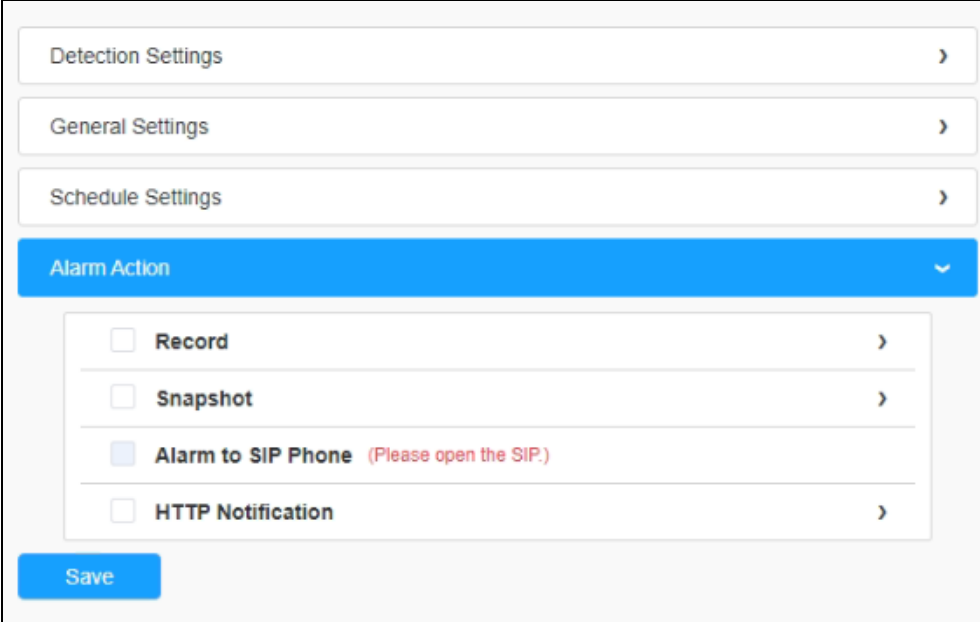
The screenshot displays the 'Schedule Settings' configuration page. At the top, there are three menu items: 'Detection Settings', 'General Settings', and 'Schedule Settings' (which is highlighted in blue). Below the menu is a 24-hour timeline grid for each day of the week (Sun. through Sat.). The timeline is currently empty, indicating no schedule is set. At the bottom of the grid are two buttons: 'Select All' and 'Clear All'. Below the grid is an 'Alarm Action' dropdown menu and a 'Save' button.

**Table 41. Description of the buttons**

Parameters	Function Introduction
	<p>Copy the schedule area to another date.</p>
	<p>Select all schedule.</p>
	<p>Clear all schedule.</p>

**[Alarm Action]**

**Step 5:** Set alarm action;



The screenshot shows a settings menu with the following items:

- Detection Settings >
- General Settings >
- Schedule Settings >
- Alarm Action** (highlighted in blue)
  - Record >
  - Snapshot >
  - Alarm to SIP Phone (Please open the SIP.)
  - HTTP Notification >

A blue Save button is located at the bottom left of the Alarm Action section.

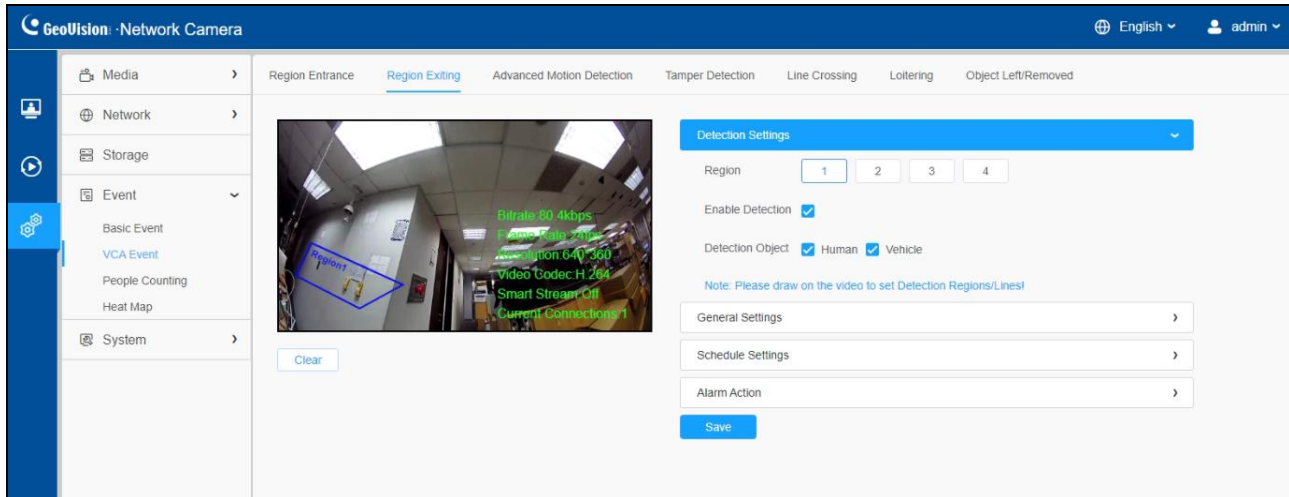
**Table 42. Description of the buttons**

Parameters	Function Introduction
Record	<p><b>Duration:</b> Selected the duration time of alarm. <b>5 s/10 s/15 s/20 s/25 s/30 s</b> are available.</p> <p><b>Linkage:</b> Save alarm recording files to SD Card or NAS or upload the recording files via FTP.</p>
Snapshot	<p><b>Number:</b> The number of snapshots, 1~5 is available.</p> <p><b>Interval:</b> This cannot be edited unless you choose more than 1 to <b>Snapshot</b>.</p> <p><b>Linkage:</b> Save alarm recording files to SD Card or NAS, upload the recording files via FTP, or send alarm emails.</p>
Alarm to SIP Phone	<p>Support to call the SIP phone after enabling the SIP function.</p> <p><b>Note:</b> Please open the SIP.</p>
HTTP Notification	<p>Support to pop up the alarm news to specified HTTP URL.</p>



### 8.4.2.2 Region Exiting

Region exiting is to make sure that any person or object won't exit the area that is being monitored. Any exit of people or objects will trigger an alarm.



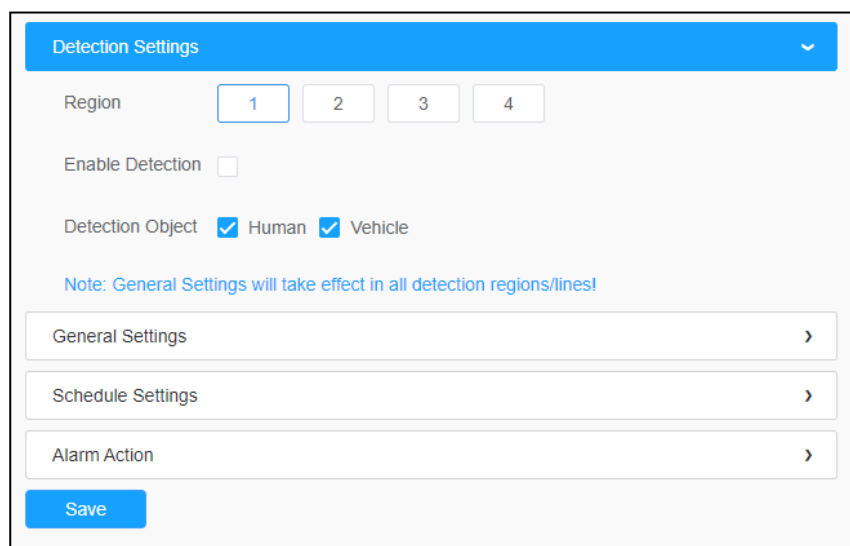
Settings steps are shown as follows:

#### [Detection Settings]

**Note:** General Settings will take effect in all detection regions/lines!

**Step 1:** Draw the detection region and enable region exiting detection;

**Step 2:** Choose detection object. Check **Human** or **Vehicle** attribute, and the camera will alarm once detecting people or vehicle and triggering related events;



#### [General Settings]

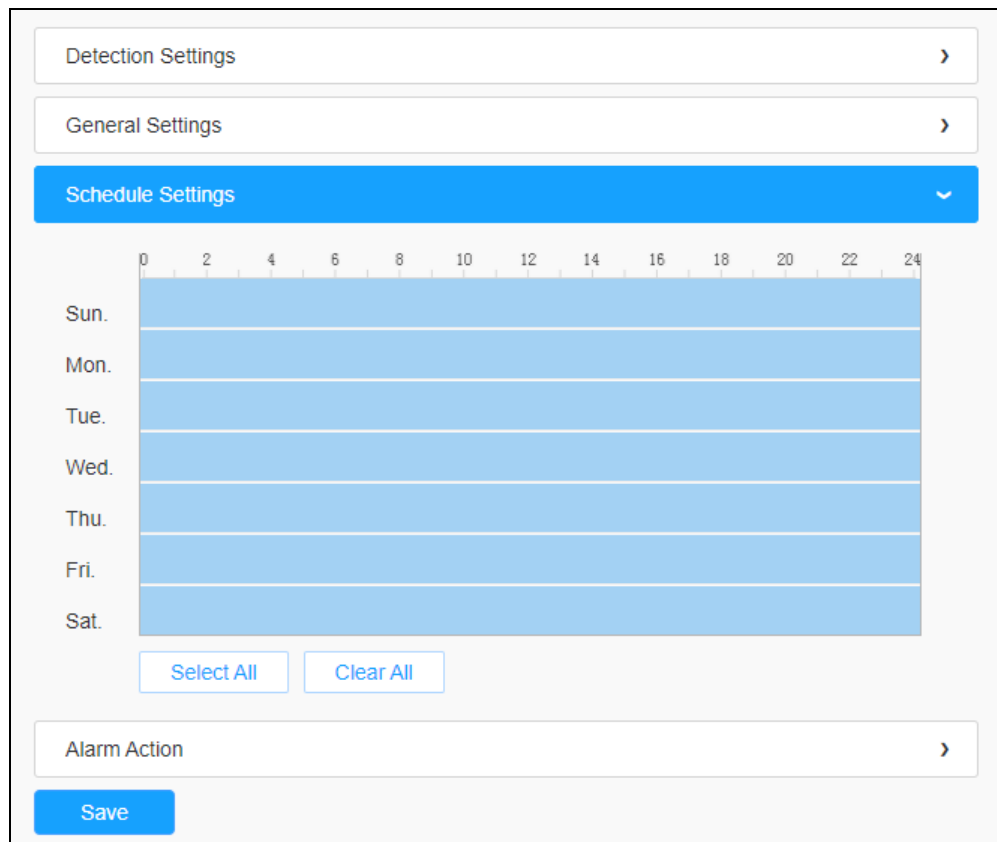
**Step 3:** Set detecting sensitivity and object size limits;

**Table 43. Description of the buttons**

Parameters	Function Introduction
<b>Sensitivity</b>	Level 1~10 is available, the default level is 5. The higher the sensitivity, the easier it is for moving objects to be recorded in the results.
<b>Min. Size</b>	Draw the screen or input pixel number to set the minimum size of the detected object. When the object is smaller than this size, it will not be detected. The default minimum size is 3*3.
<b>Max. Size</b>	Draw the screen or input pixel number to set the maximum size of the detected object. When the object is larger than this size, it will not be detected. The default maximum size is 320*240.

**[Schedule Settings]**

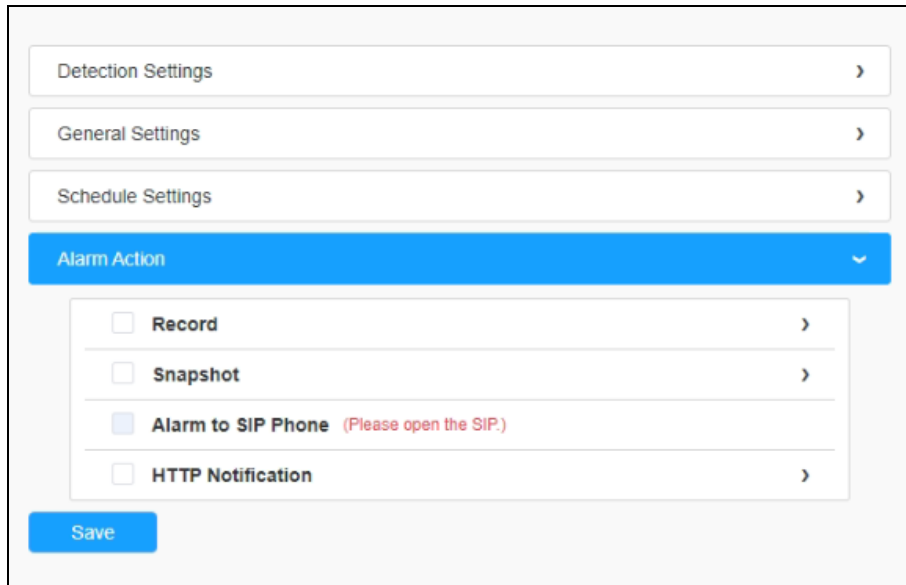
**Step 4:** Set detection schedule;



**Note:** Refer to *Table 41* of *8.4.2.1 Region Entrance* for details.

**[Alarm Action]**

**Step 5:** Set alarm action;



The screenshot shows a settings interface with a sidebar on the left containing four menu items: 'Detection Settings', 'General Settings', 'Schedule Settings', and 'Alarm Action'. The 'Alarm Action' menu item is highlighted in blue and has a downward arrow. Below the sidebar, there is a list of four alarm actions, each with a checkbox and a right-pointing arrow:

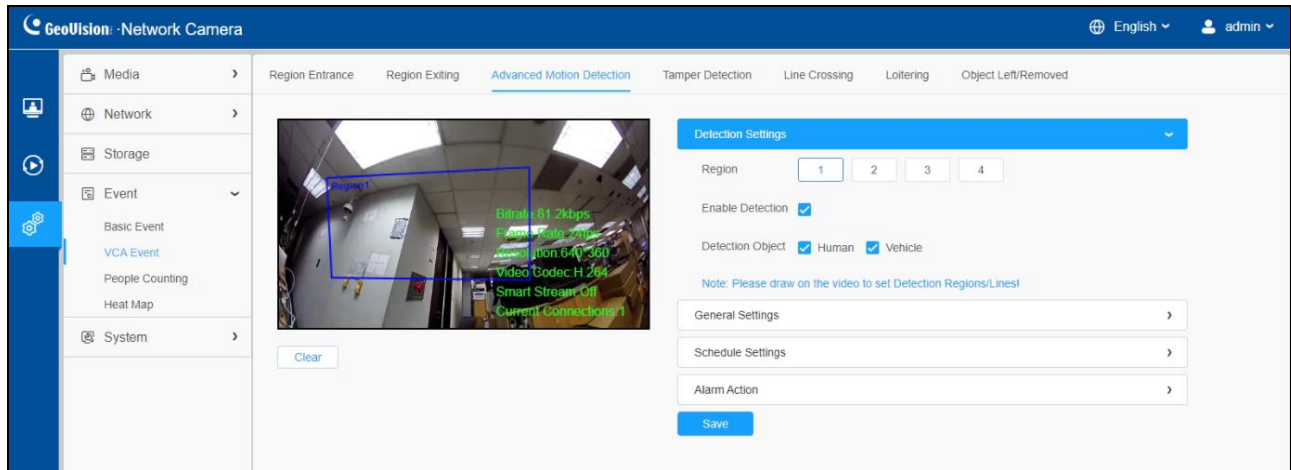
- Record
- Snapshot
- Alarm to SIP Phone (Please open the SIP.)
- HTTP Notification

At the bottom left of the main content area, there is a blue 'Save' button.

**Note:** Refer to *Table 42* of *8.4.2.1 Region Entrance* for details.

### 8.4.2.3 Advanced Motion Detection

Different from traditional motion detection, advanced motion detection can filter out “noise” such as lighting changes, natural tree movements, etc. When an object moves in the selected area, it will trigger alarm.



Settings steps are shown as follows:

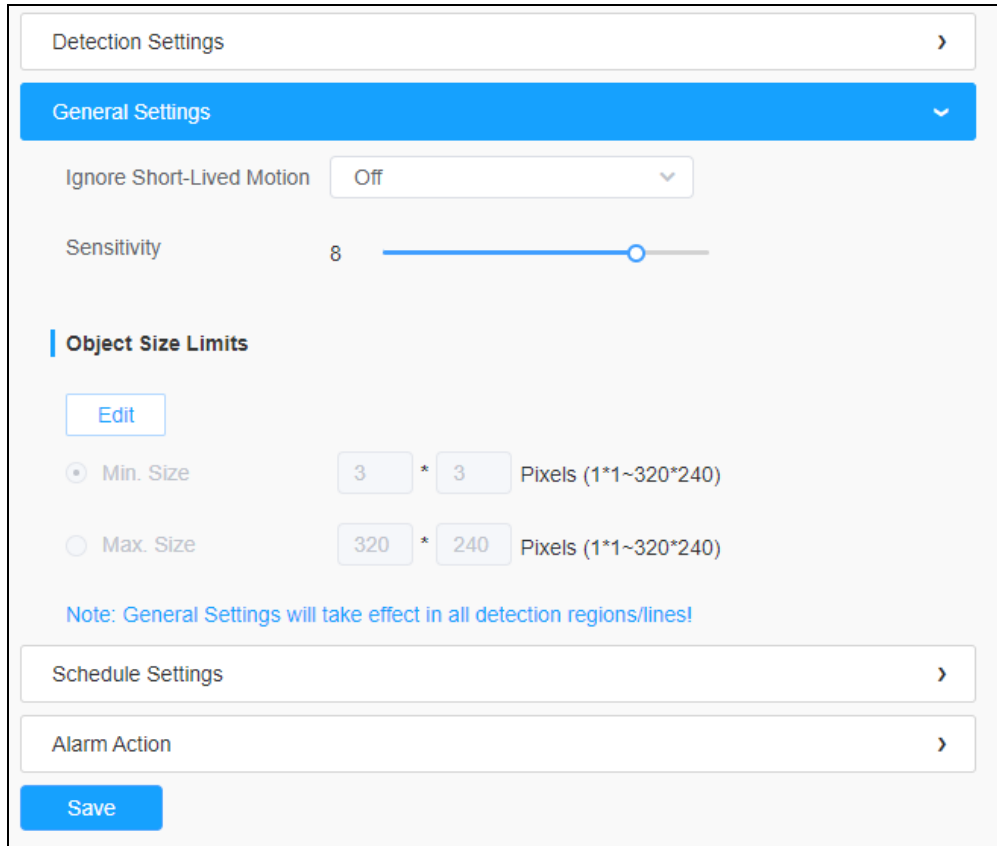
**Step 1:** Draw the detection region and enable advanced motion detection;

**Step 2:** Choose detection object. Check **Human** or **Vehicle** attribute, and the camera will alarm once detecting people or vehicle and triggering related events;

#### [General Settings]

**Step 3:** Set **Ignore Short-Lived Motion** time. If you set the time, when the moving duration of an object is within the setting time, the alarm will not be triggered;

**Step 4:** Set detecting sensitivity and object size limits;



The screenshot shows a web interface for 'Detection Settings'. At the top, there are three expandable sections: 'Detection Settings', 'General Settings' (which is currently expanded), and 'Schedule Settings'. Below 'General Settings', there is a dropdown for 'Ignore Short-Lived Motion' set to 'Off', and a slider for 'Sensitivity' set to 8. Underneath is a section titled 'Object Size Limits' with an 'Edit' button. It contains two radio buttons: 'Min. Size' (selected) with input fields for '3' and '3' (labeled 'Pixels (1\*1~320\*240)'), and 'Max. Size' with input fields for '320' and '240' (labeled 'Pixels (1\*1~320\*240)'). A blue note states: 'Note: General Settings will take effect in all detection regions/lines!'. At the bottom of the settings panel are sections for 'Alarm Action' and a blue 'Save' button.

**Table 44. Description of the buttons**

Parameters	Function Introduction
<b>Ignore Short-Lived Motion</b>	<p>The alarm will not be triggered when the moving duration of an object is within the setting time. <b>Off/1 s/2 s/3 s/4 s/5 s</b> are available.</p> <p><b>Note:</b> Ignore Short-Lived Motion time is to avoid false alarm caused by instant object movement within time setting.</p>
<b>Sensitivity</b>	<p>Level 1~10 is available, the default level is 5. The higher the sensitivity, the easier it is for moving objects to be recorded in the results.</p> <p><b>Note:</b> The sensitivity can be configured to detect various movement according to different requirements. When the level of sensitivity is low, slight movement won't trigger the alarm.</p>
<b>Min. Size</b>	<p>Draw the screen or input pixel number to set the minimum size of the detected object. When the object is smaller than this size, it will not be detected. The default minimum size is 3*3.</p>

<b>Max. Size</b>	Draw the screen or input pixel number to set the maximum size of the detected object. When the object is larger than this size, it will not be detected. The default maximum size is 320*240.
------------------	---

**[Schedule Settings]**

**Step5:** Set detection schedule;

**Note:** Refer to *Table 41 of 8.4.2.1 Region Entrance* for details.

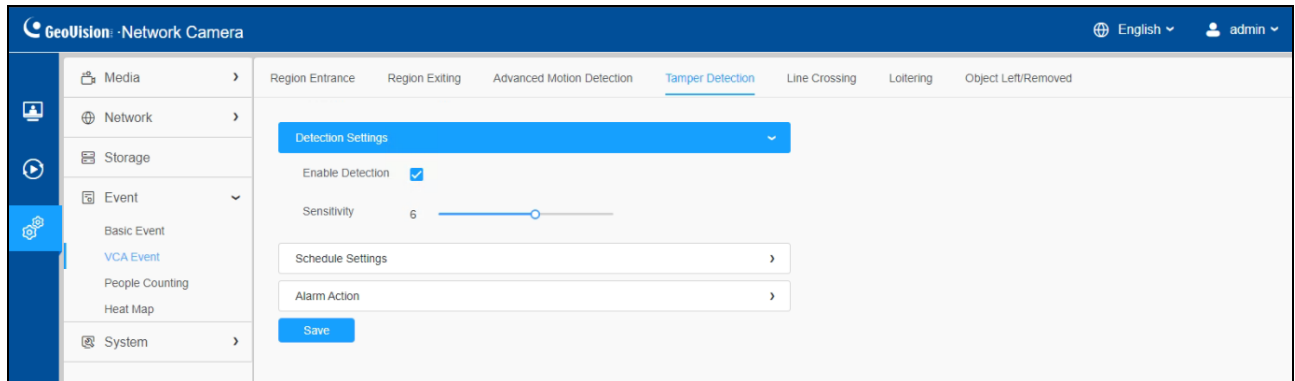
**[Alarm Action]**

**Step6:** Set alarm action;

**Note:** Refer to *Table 42 of 8.4.2.1 Region Entrance* for details.

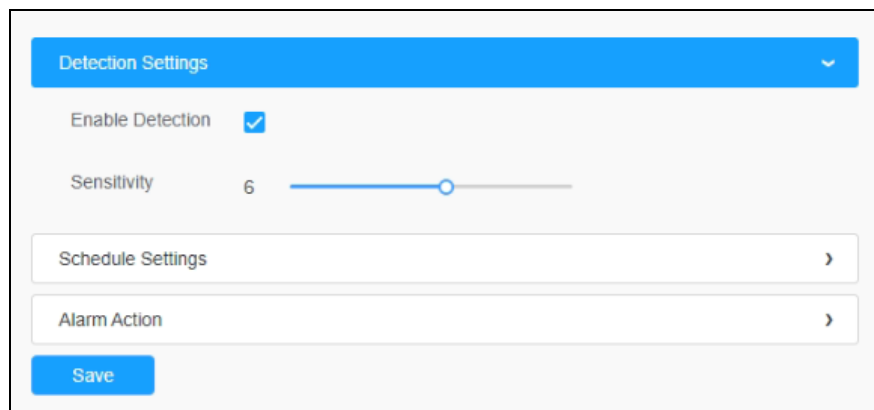
#### 8.4.2.4 Tamper Detection

Tamper Detection is used to detect possible tampering like the camera being unfocused, obstructed or moved. This functionality alerts security staff immediately when any above-mentioned actions occur.



Settings steps are shown as follows:

**Step 1:** Enable Tamper Detection and set detecting sensitivity;



#### [Schedule Settings]

**Step 2:** Set detection schedule;

**Note:** Refer to *Table 41* of *8.4.2.1 Region Entrance* for details.

**[Alarm Action]**

**Step3:** Set alarm action;

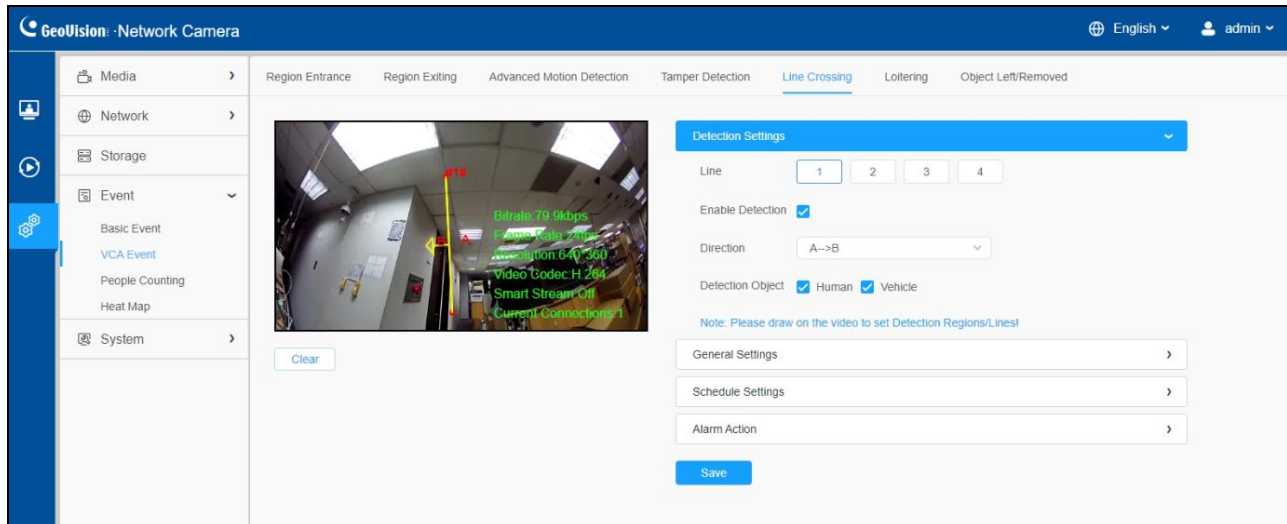
**Note:**

- Refer to *Table 41 of 8.4.2.1 Region Entrance* for details.
- The algorithm supports defocus detection in Tamper Detection function.



### 8.4.2.5 Line Crossing

Line Crossing detection is designed to work in most indoor and outdoor environment. An event will be triggered every time when the camera detects objects crossing a defined virtual line.



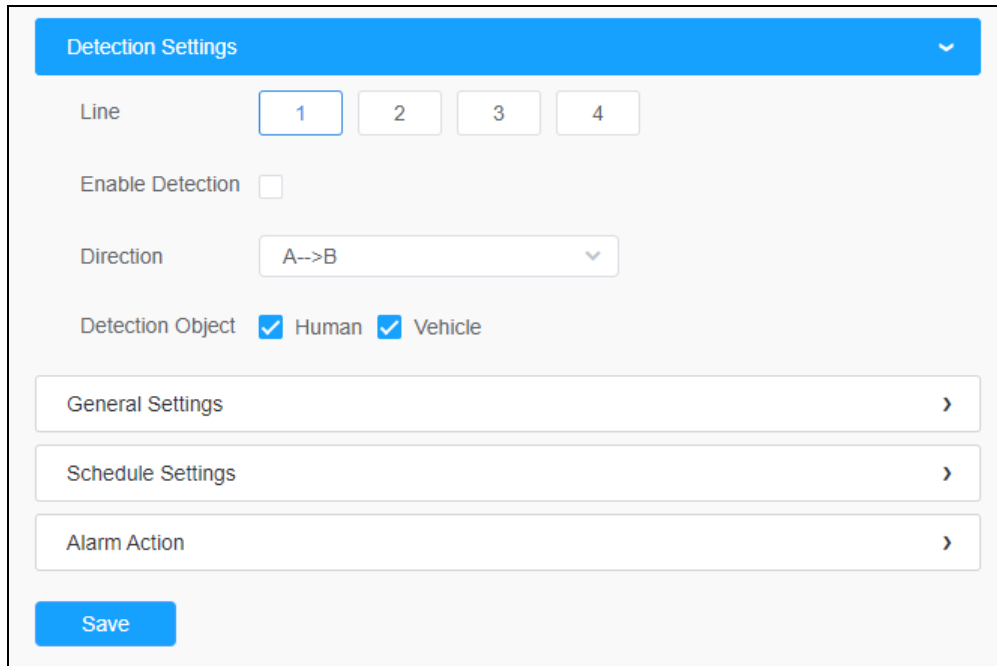
Settings steps are shown as follows:

#### [Detection Settings]

**Step 1:** Draw the detection line, enable line crossing detection, and define its direction;

**Note:** Allows to set up to four lines at a time. There are three direction modes to choose for triggering alarm. “**A**→**B**” means when there is any object crossing the line from the “A” side to the “B” side, the alarm will be triggered. “**B**→**A**” vice versa. “**A** ↔ **B**” means that the alarm will be triggered when objects cross line from either side.

**Step 2:** Choose detection object. Check **Human** or **Vehicle** attribute, and the camera will alarm once detecting people or vehicle and triggering related events;



Detection Settings

Line: 1 2 3 4

Enable Detection:

Direction: A->B

Detection Object:  Human  Vehicle

General Settings >

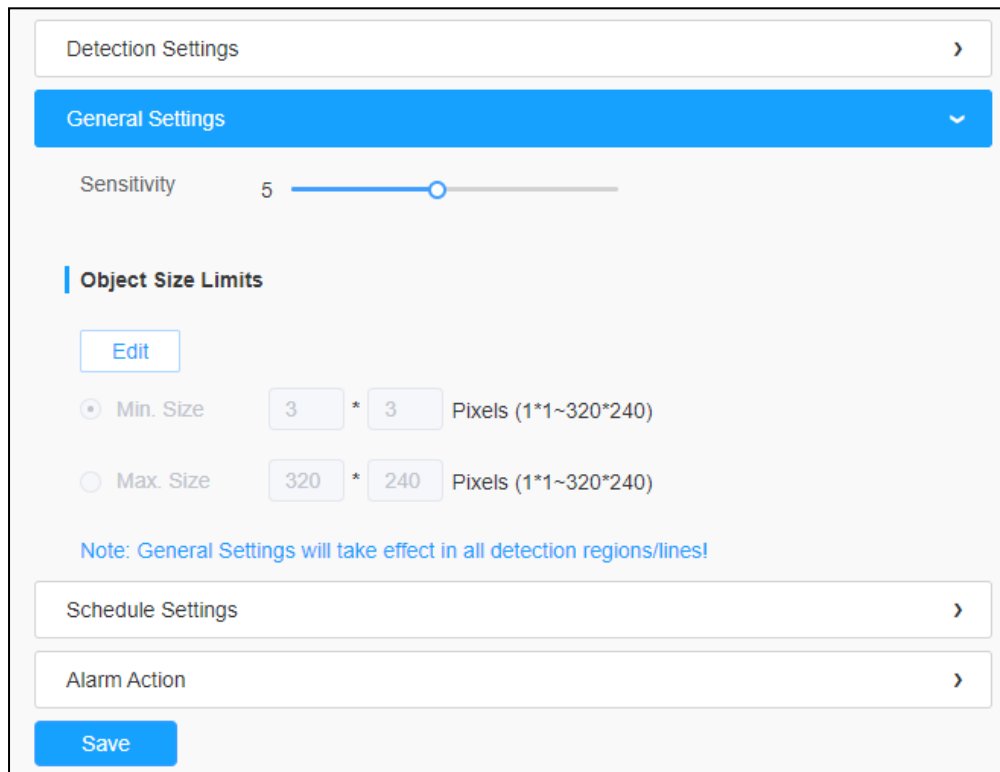
Schedule Settings >

Alarm Action >

Save

**[General Settings]**

**Step 3:** Set detecting sensitivity and object size limits;



Detection Settings >

General Settings

Sensitivity: 5

**Object Size Limits**

Edit

Min. Size: 3 \* 3 Pixels (1\*1~320\*240)

Max. Size: 320 \* 240 Pixels (1\*1~320\*240)

Note: General Settings will take effect in all detection regions/lines!

Schedule Settings >

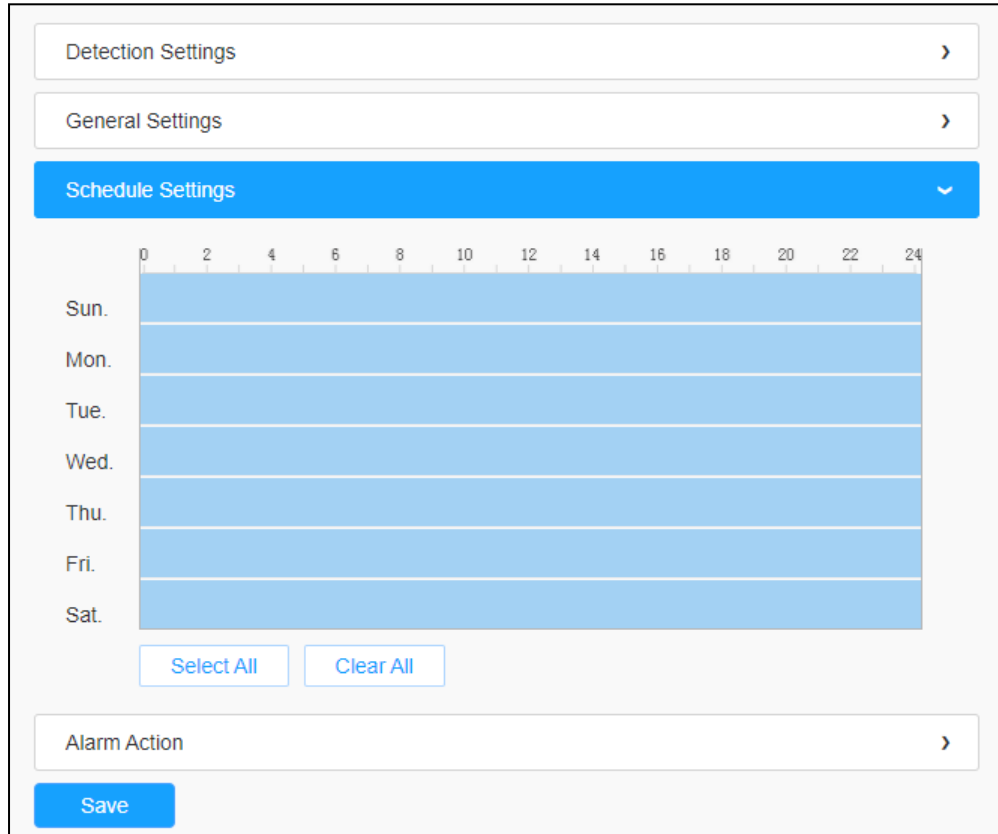
Alarm Action >

Save

**Note:** Refer to *Table 40* of *8.4.2.1 Region Entrance* for details.

## [Schedule Settings]

**Step 4:** Set detection schedule;



The screenshot shows a web interface for configuring detection settings. At the top, there are three menu items: 'Detection Settings', 'General Settings', and 'Schedule Settings'. 'Schedule Settings' is highlighted in blue. Below the menu is a 24-hour time scale from 0 to 24. Underneath the time scale are seven rows representing the days of the week: Sun., Mon., Tue., Wed., Thu., Fri., and Sat. Each row is a solid blue bar, indicating that the detection is active for the entire 24 hours of every day. Below the calendar are two buttons: 'Select All' and 'Clear All'. At the bottom of the interface, there is an 'Alarm Action' dropdown menu and a blue 'Save' button.

**Note:** Refer to *Table 41* of *8.4.2.1 Region Entrance* for details.

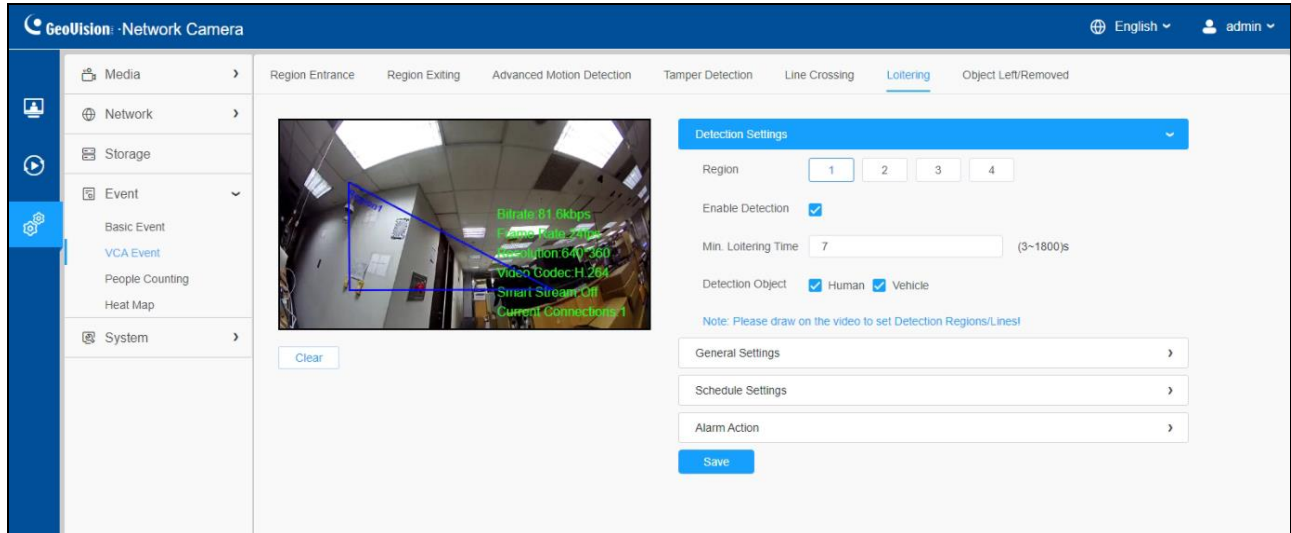
## [Alarm Action]

**Step 5:** Set alarm action;

**Note:** Refer to *Table 42* of *8.4.2.1 Region Entrance* for details.

## 8.4.2.6 Loitering

When objects are loitering in a defined area for a specific period of time, it would trigger an alarm.



Settings steps are shown as follows:

### [Detection Settings]

**Note:** General Settings will take effect in all detection regions/lines!

**Step 1:** Draw the detection region and enable loitering detection;

**Step 2:** Set **Min. Loitering Time**. After setting minimum loitering time from 3s to 1800s, any objects loitering in the selected area over the minimum loitering time will trigger the alarm;

**Step 3:** Choose detection object. Check **Human** or **Vehicle** attribute, and the camera will alarm once detecting people or vehicle and triggering related events;

**Detection Settings** ▼

Region

Enable Detection

Min. Loitering Time  (3~1800)s

Detection Object  Human  Vehicle

Note: General Settings will take effect in all detection regions/lines!

General Settings ›

Schedule Settings ›

Alarm Action ›

**Save**

### [General Settings]

**Step 4:** Set object size limits;

Detection Settings ›

**General Settings** ▼

**Object Size Limits**

Min. Size  \*  Pixels (1\*1~320\*240)

Max. Size  \*  Pixels (1\*1~320\*240)

Note: General Settings will take effect in all detection regions/lines!

Schedule Settings ›

Alarm Action ›

**Save**

**Table 45. Description of the buttons**

Parameters	Function Introduction
<b>Min. Size</b>	Draw the screen or input pixel number to set the minimum size of the detected object. When the object is smaller than this size, it will not be detected. The default minimum size is 3*3.
<b>Max. Size</b>	Draw the screen or input pixel number to set the maximum size of the detected object. When the object is larger than this size, it will not be detected. The default maximum size is 320*240.

**[Schedule Settings]**

**Step 5:** Set detection schedule;

**Note:** Refer to *Table 41 of 8.4.2.1 Region Entrance* for details.

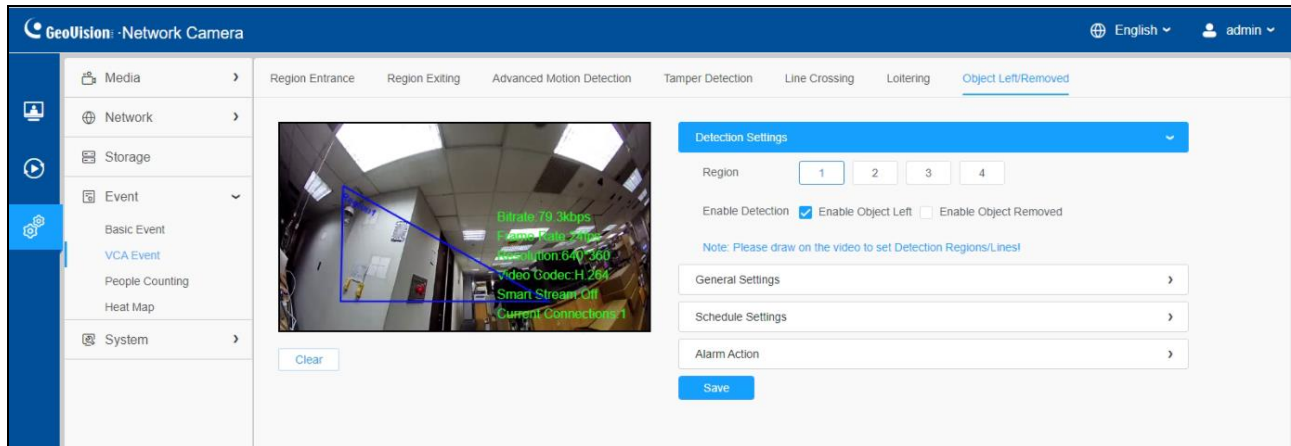
**[Alarm Action]**

**Step 6:** Set alarm action;

**Note:** Refer to *Table 42 of 8.4.2.1 Region Entrance* for details.

### 8.4.2.7 Object Left/ Removed

Object Left can detect and prompt an alarm if an object is left in a pre-defined region. Object Removed can detect and prompt an alarm if an object is removed from a pre-defined region.

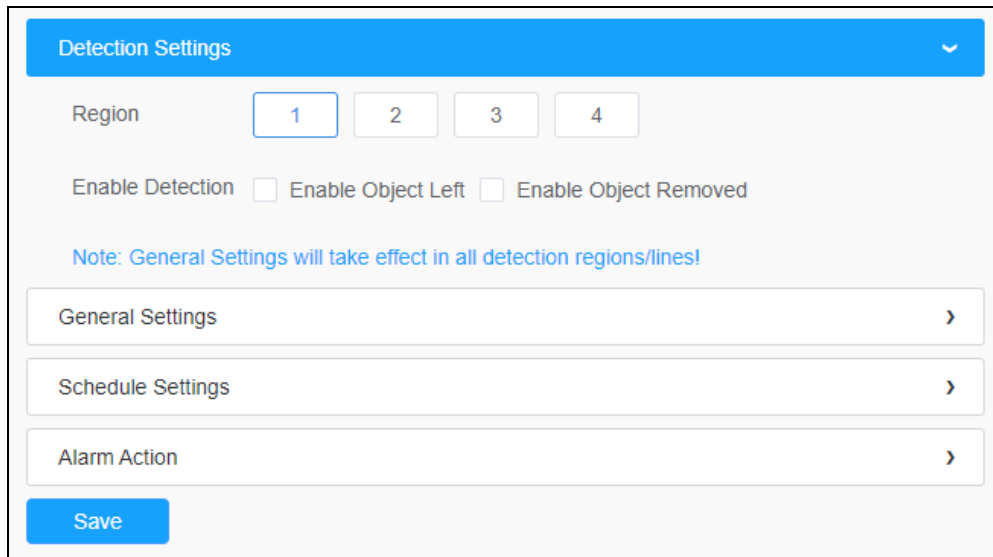


Settings steps are shown as follows:

#### [Detection Settings]

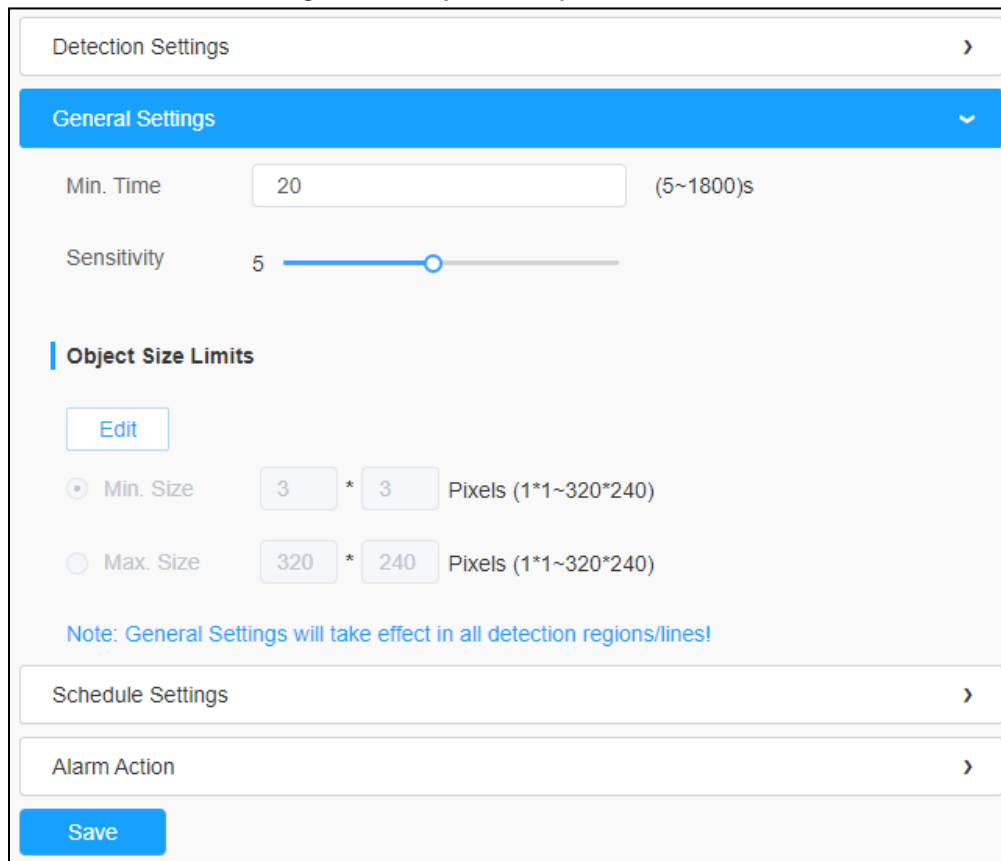
**Note:** General Settings will take effect in all detection regions/lines!

**Step 1:** Draw the detection region and enable object left/removed detection (Or enable both features at the same time);



### [General Settings]

**Step 2:** Set Min. time, detecting sensitivity and object size limits.





**Table 46. Description of the buttons**

Parameters	Function Introduction
<b>Min. Time</b>	After setting Min. time from 5s to 1800s, any objects are left in the selected area or removed from the selected area over the minimum time will trigger the alarm.
<b>Sensitivity</b>	Level 1~10 is available, the default level is 5. The higher the sensitivity, the easier it is for moving objects to be recorded in the results. <b>Note:</b> The sensitivity can be configured to detect various movement according to different requirements. When the level of sensitivity is low, slight movement won't trigger the alarm.
<b>Min. Size</b>	Draw the screen or input pixel number to set the minimum size of the detected object. When the object is smaller than this size, it will not be detected. The default minimum size is 3*3.
<b>Max. Size</b>	Draw the screen or input pixel number to set the maximum size of the detected object. When the object is larger than this size, it will not be detected. The default maximum size is 320*240.

**[Schedule Settings]**

**Step 3:** Set detection schedule;

**Note:** Refer to *Table 41 of 8.4.2.1 Region Entrance* for details.

**[Alarm Action]**

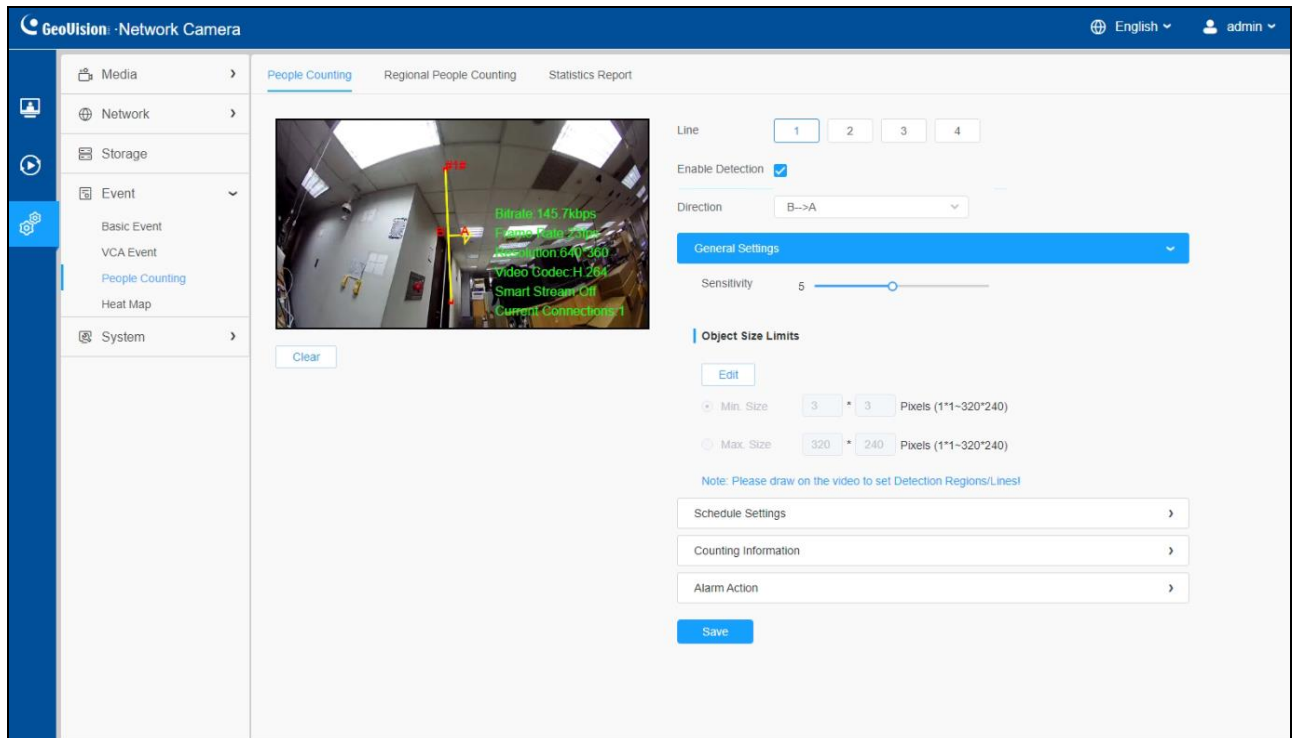
**Step 4:** Set alarm action;

**Note:** Refer to *Table 42 of 8.4.2.1 Region Entrance* for details.

## 8.4.3 People Counting

### 8.4.3.1 People Counting

People Counting is able to count how many people enter or exit during the setting period.



Settings steps are as shown below:

**Step 1:** Enable People Counting Detection;

**Step 2:** Draw the detection line and select the detection direction.

**Note:**

- Crossing along the direction of the arrow will be recorded as “In”, opposite is “Out”.
- Support up to 4 detection lines.

## [General Settings]

**Step 3:** Set sensitivity and object size limits.

Line

Enable Detection

Direction

**General Settings** ▾

Sensitivity 5

**Object Size Limits**

Min. Size  \*  Pixels (1\*1~320\*240)

Max. Size  \*  Pixels (1\*1~320\*240)

Note: General Settings will take effect in all detection regions/lines!

Schedule Settings ▸

Counting Information ▸

Alarm Action ▸

**Table 47. Description of the buttons**

<b>Parameters</b>	<b>Function Introduction</b>
<b>Sensitivity</b>	Level 1~10 is available, the default level is 5. The higher the sensitivity, the easier it is for moving objects to be recorded in the results.
<b>Min. Size</b>	Draw the screen or input pixel number to set the minimum size of the detected object. When the object is smaller than this size, it will not be detected. The default minimum size is 3*3.
<b>Max. Size</b>	Draw the screen or input pixel number to set the maximum size of the detected object. When the object is larger than this size, it will not be detected. The default maximum size is 320*240.

**[Schedule Settings]**

**Step 4:** Set detection schedule;

**Note:** Refer to *Table 41 of 8.4.2.1 Region Entrance* for details.

**[Counting Information]**

**Step 5: Set counting information;**

**Counting Information** ▼

Count Type  All  
 In  Out  Sum  Capacity

**Total Counting** ⓘ

Show OSD

Font Size

Font Color

Text Position

**Single Counting**

Show Information

Manual Reset   
 Reset the statistics report together?

Auto Reset

Day

Time

Alarm Action

**Table 48. Description of the buttons**

Parameters	Function Introduction
<b>Count Type</b>	Users can choose the information they want to display in Live Video.
<b>Total Counting</b>	<p>Set counting OSD.</p> <p><b>Note:</b> The Total Counting OSD configuration is linked in all detection lines.</p> <p><b>Show OSD:</b> Click to enable/disable the OSD shown.</p> <p><b>Font Size:</b> The font size of the OSD display.</p> <p><b>Font Color:</b> The font color of the OSD display.</p> <p><b>Text Position:</b> The text position of the OSD display.</p>
<b>Single Counting</b>	<p>Set Single Counting.</p> <p><b>Note:</b> The Total Counting OSD configuration is linked in all detection lines.</p> <p><b>Show Information:</b> Click to show the information.</p> <p><b>Manual Reset:</b> Reset the counting of each single line. You can choose to reset the statistics report together.</p> <p><b>Auto Reset:</b> It is used to automatically clear the single counting information.</p> <p><b>Day:</b> The day of <b>Auto Reset</b>.</p> <p><b>Time:</b> The time of <b>Auto Reset</b>.</p>

## [Alarm Action]

**Step 6:** Set alarm trigger and alarm action;

Direction B->A

General Settings >

Schedule Settings >

Counting Information >

**Alarm Action** v

**Alarm Trigger**

Total Counting  Single Counting

Thresholds

<input type="checkbox"/> In	<input type="text" value="9999"/>	<input type="checkbox"/> Out	<input type="text" value="9999"/>
<input type="checkbox"/> Capacity	<input type="text" value="9999"/>	<input type="checkbox"/> Sum	<input type="text" value="9999"/>

**Alarm Action**

<input type="checkbox"/> Record	>
<input type="checkbox"/> Snapshot	>
<input checked="" type="checkbox"/> Alarm to SIP Phone <small>(Please open the SIP)</small>	
<input type="checkbox"/> HTTP Notification	>

**Table 49. Description of the buttons**

<b>Parameters</b>	<b>Function Introduction</b>
<b>Alarm Trigger</b>	<p>Alarm will be triggered when the thresholds reach to a certain value from 1 to 9999. <b>Total Counting</b> and <b>Single Counting</b> are available. You can set the <b>Thresholds</b> of <b>In/Out/Capacity/Sum</b>.</p> <p><b>Note:</b></p> <ul style="list-style-type: none"> <li>• For <b>Total Counting</b>, the thresholds are the sum of the total number of 4 detection lines.</li> <li>• For <b>Single Counting</b>, the threshold is for the selected detection line.</li> </ul>
<b>Alarm Action</b>	<p>Refer to <i>Table 42</i> of <i>8.4.2.1 Region Entrance</i> for details.</p> <p><b>Note:</b> The alarm action is effective on 4 detection lines simultaneously.</p>

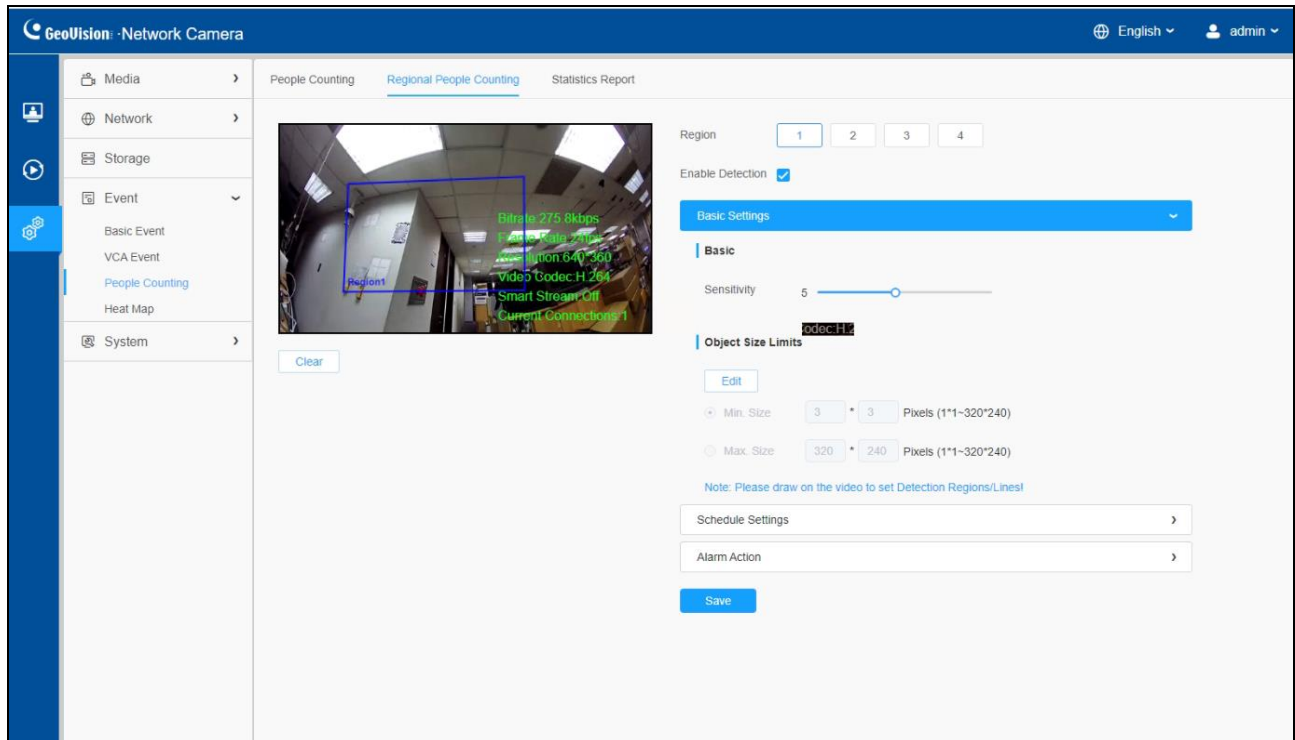


### 8.4.3.2 Regional People Counting

When enabling Regional People Counting, users can check the real-time number of people and the time of each person's stay in the detection region.

**Note:**

- Support up to 4 detection regions for regional people counting.
- Users can check the real-time number of people and the time of each person's stay in the detection region on Live View interface.

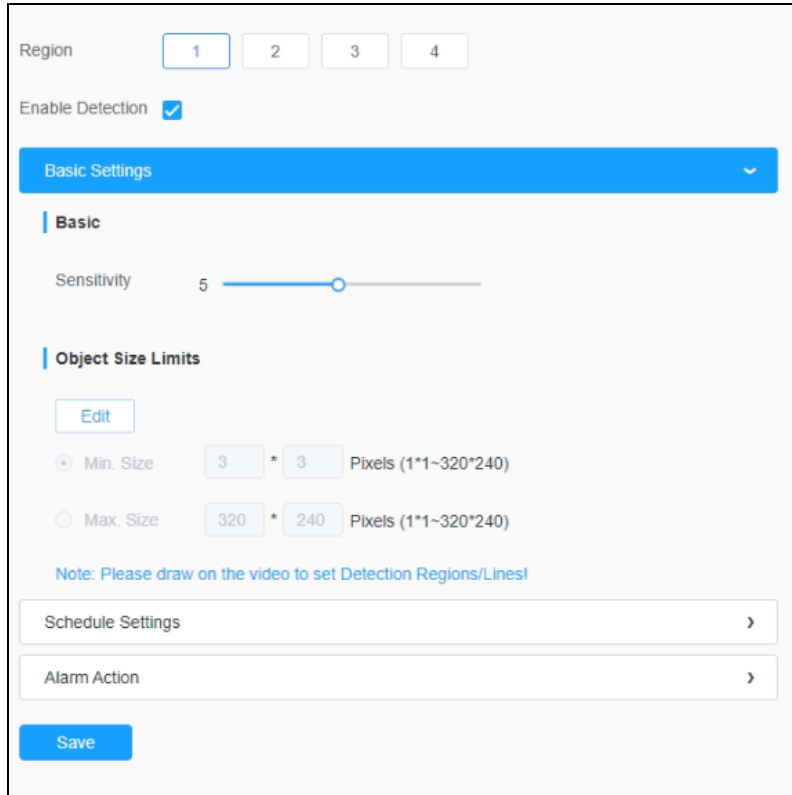


Settings steps are as shown below:

**Step 1:** Draw the detection region and enable regional people counting detection;

**[Basic Settings]**

**Step 2:** Set sensitivity and object size limits.



The screenshot shows a configuration window for detection settings. At the top, there are four region selection buttons labeled 1, 2, 3, and 4. Below them is a checkbox for 'Enable Detection' which is checked. A blue header bar contains 'Basic Settings'. Underneath, there are two sections: 'Basic' and 'Object Size Limits'. In the 'Basic' section, there is a 'Sensitivity' slider set to 5. The 'Object Size Limits' section has an 'Edit' button and two radio buttons: 'Min. Size' (selected) with input fields for 3 and 3, and 'Max. Size' with input fields for 320 and 240. A note below reads 'Note: Please draw on the video to set Detection Regions/Lines!'. At the bottom, there are expandable sections for 'Schedule Settings' and 'Alarm Action', and a blue 'Save' button.

**Table 50. Description of the buttons**

Parameters	Function Introduction
<b>Sensitivity</b>	Level 1~10 is available, the default level is 5. The higher the sensitivity, the easier it is for moving objects to be recorded in the results.
<b>Object Size Limits</b>	<p><b>Min. Size:</b> Draw the screen or input pixel number to set the minimum size of the detected object. When the object is smaller than this size, it will not be detected. The default minimum size is 3*3.</p> <p><b>Max. Size:</b> Draw the screen or input pixel number to set the maximum size of the detected object. When the object is larger than this size, it will not be detected. The default maximum size is 320*240.</p>

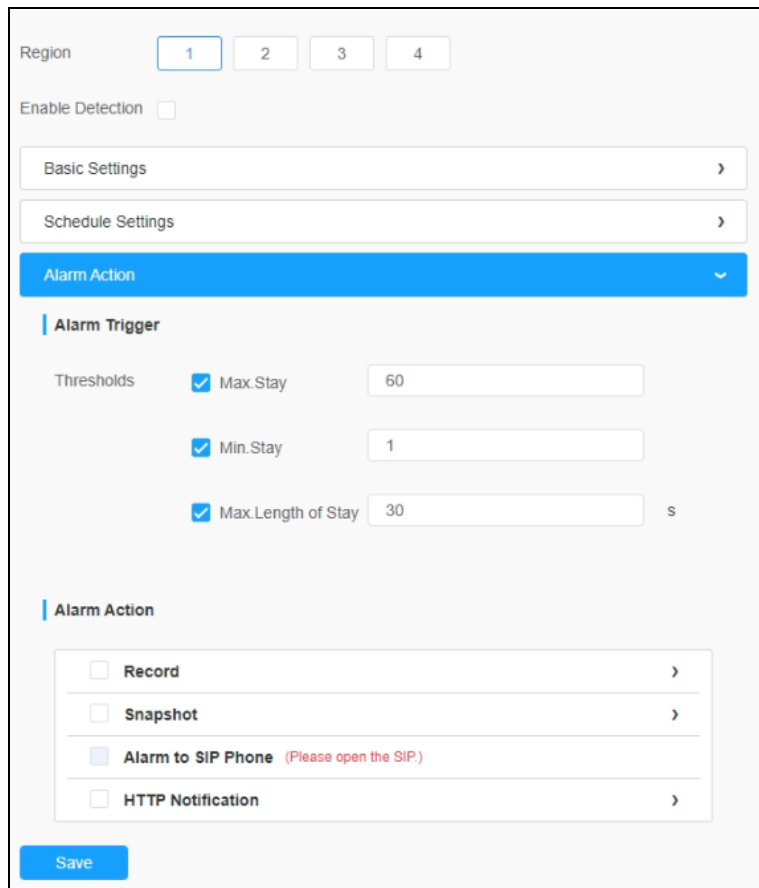
## [Schedule Settings]

**Step4:** Set detection schedule;

**Note:** Refer to *Table 41 of 8.4.2.1 Region Entrance* for details.

## [Alarm Action]

**Step6:** Set alarm trigger and alarm action;



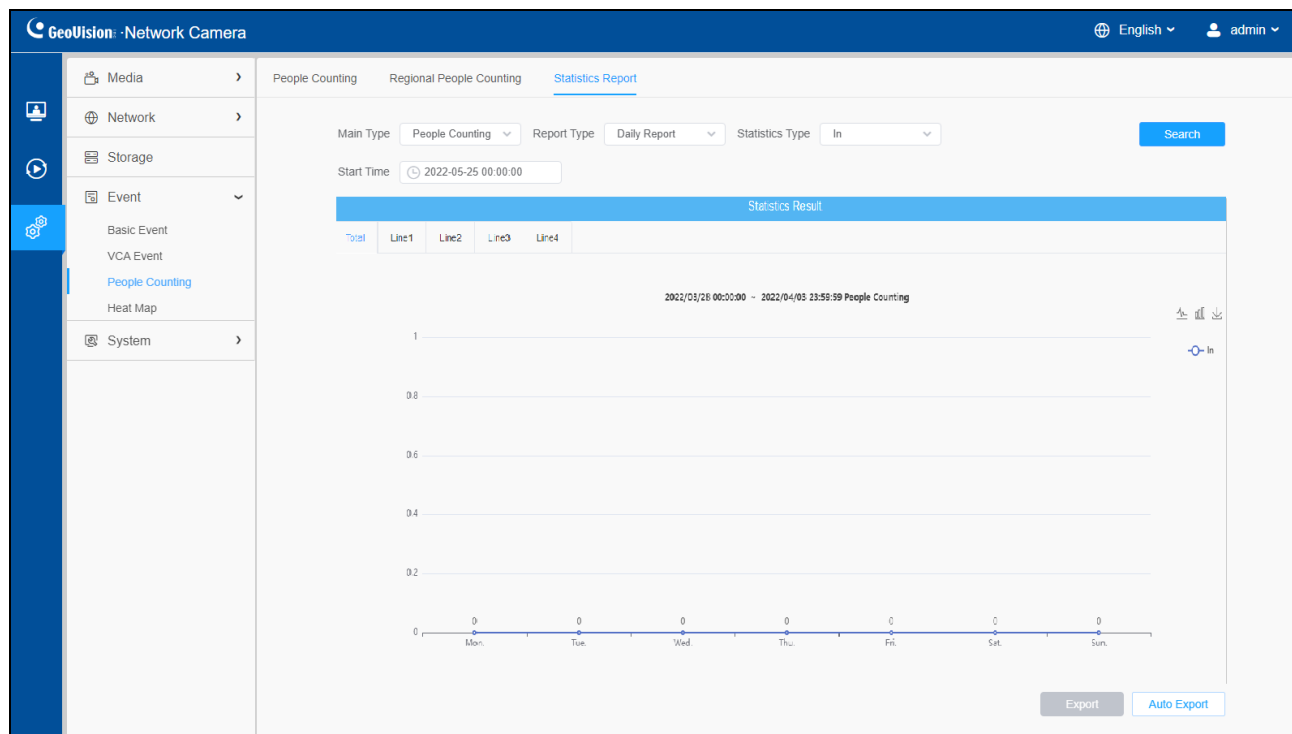
The screenshot shows a configuration window for 'Alarm Action' settings. At the top, there are four buttons labeled '1', '2', '3', and '4' under the heading 'Region'. Below this is a checkbox for 'Enable Detection' which is currently unchecked. There are three expandable sections: 'Basic Settings', 'Schedule Settings', and 'Alarm Action'. The 'Alarm Action' section is highlighted in blue and contains two sub-sections: 'Alarm Trigger' and 'Alarm Action'. Under 'Alarm Trigger', there are three checked checkboxes with corresponding input fields: 'Max.Stay' (60), 'Min.Stay' (1), and 'Max.Length of Stay' (30) with a unit 's'. Under 'Alarm Action', there are four unchecked checkboxes: 'Record', 'Snapshot', 'Alarm to SIP Phone' (with a red note '(Please open the SIP.)'), and 'HTTP Notification'. A blue 'Save' button is located at the bottom left of the configuration area.

**Table 51. Description of the buttons**

Parameters	Function Introduction
<p align="center"><b>Alarm Trigger</b></p>	<p>Alarm will be triggered when the Max./Min. Stay/Max. Length of Stay thresholds reaches to the value.  <b>Note:</b> The value must be in the range of 1 to 60.</p>
<p align="center"><b>Alarm Action</b></p>	<p>Refer to Table 42 of <i>8.5.2.1 Region Entrance</i> for details.  <b>Note:</b> The alarm action is effective on 4 detection regions simultaneously.</p>

### 8.4.3.3 Statistics Report

The results during the enabling period will be displayed on “**Statistics Report**” interface.



**Step 1:** Select **Main Type**;

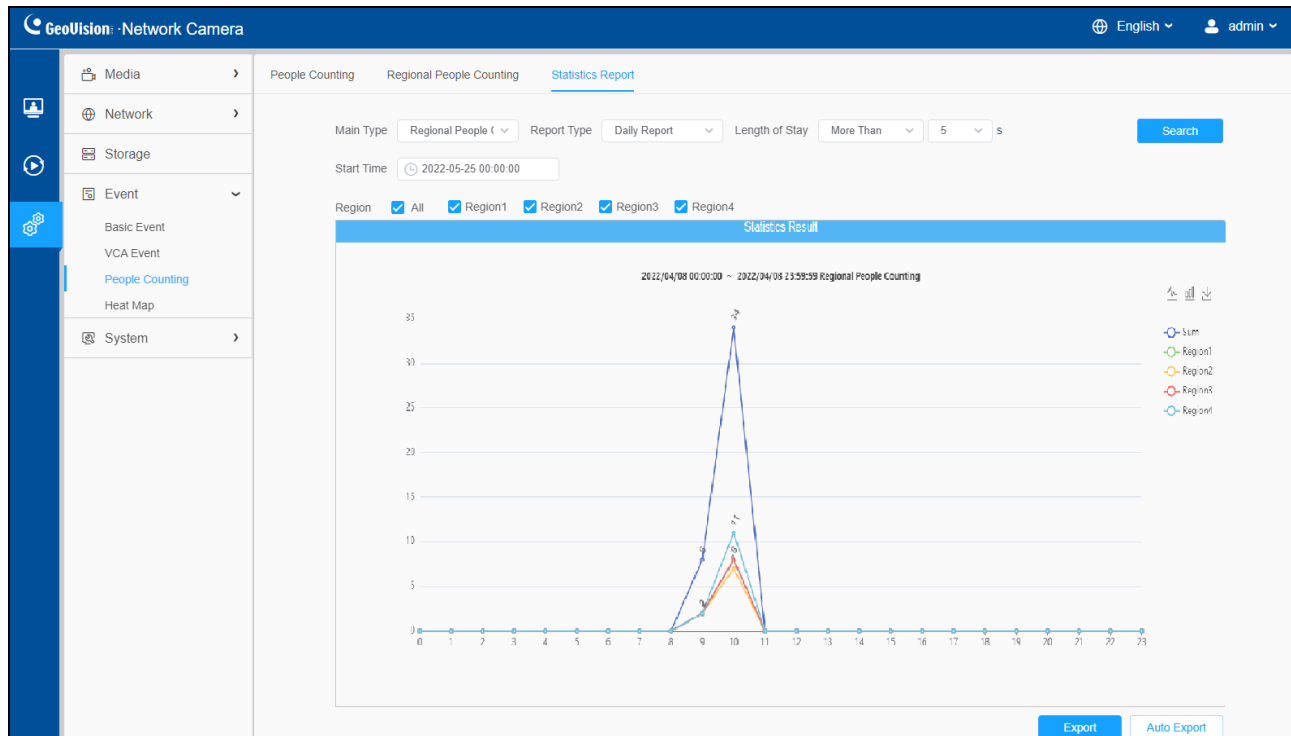
**Step2:** Select **Report Type** including **Daily Report**, **Weekly Report**, **Monthly Report** and **Annual Report**;

**Step3:** For People Counting, select **Statistics Type** including **In**, **Out** or **Sum**. For Regional People Counting, select **Length of Stay** including **All**, **More Than** or **Less Than** and set the time of more than/less then.

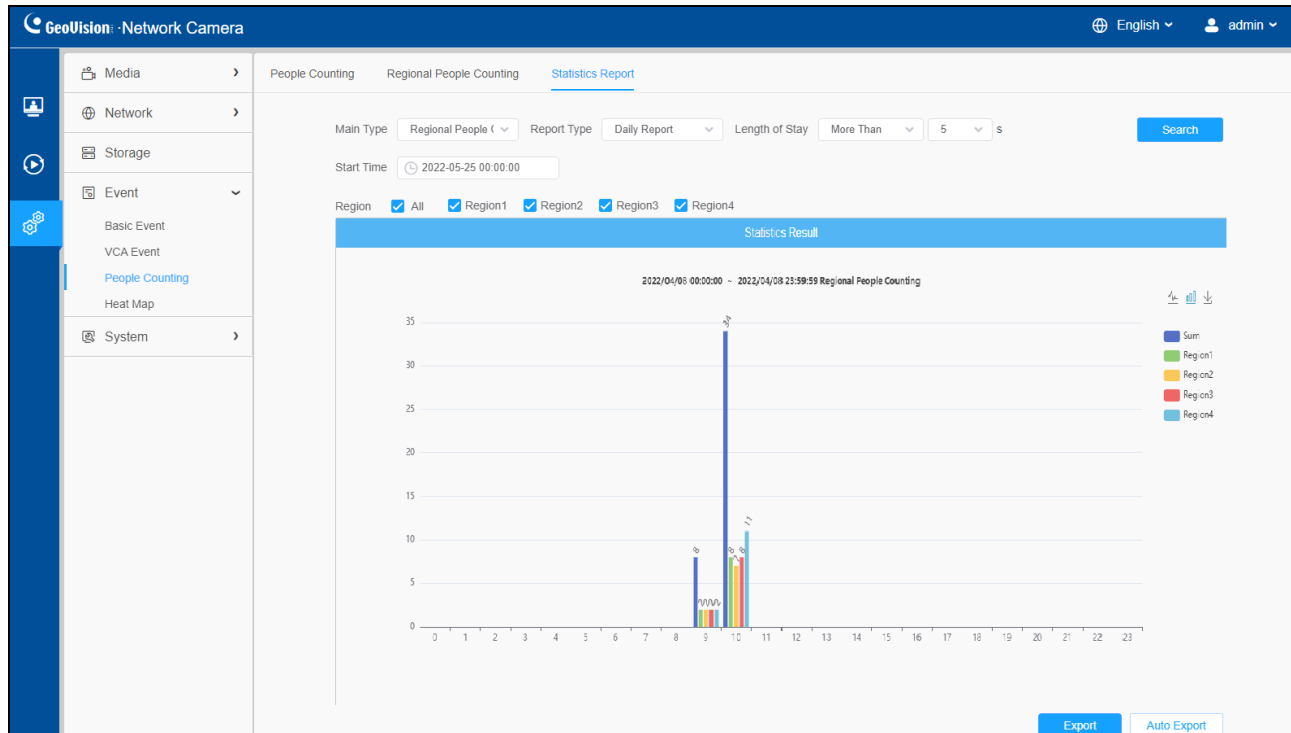
**Note:** For Regional People Counting, check the check boxes next to **Region** to search the report of regions as needed.




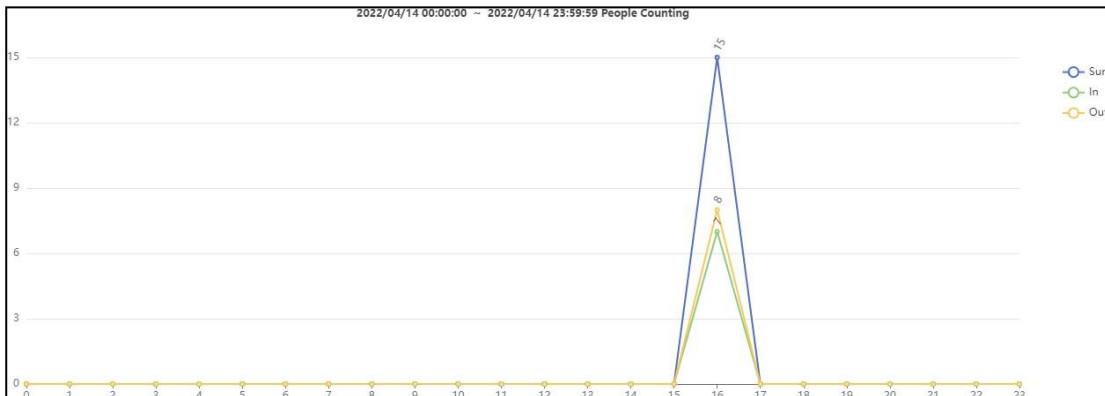
## [Regional People Counting-Statistics Report (Line Chart)]



## [Regional People Counting-Statistics Report (Bar Chart)]

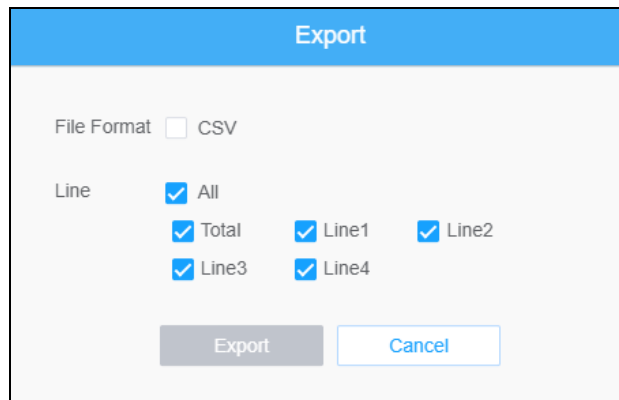


**Step6:** Click "Download" button  to download the screenshot of the statistical report chart.

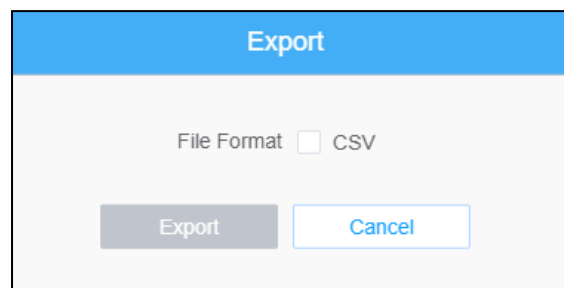


**Step7:** Click **Export** to pop up the Export window as shown below, and you can choose **File Format** to export the report to local. For People Counting Statistics Report, you can check the check box to export the report of different lines as needed.

**[People Counting-Export]**



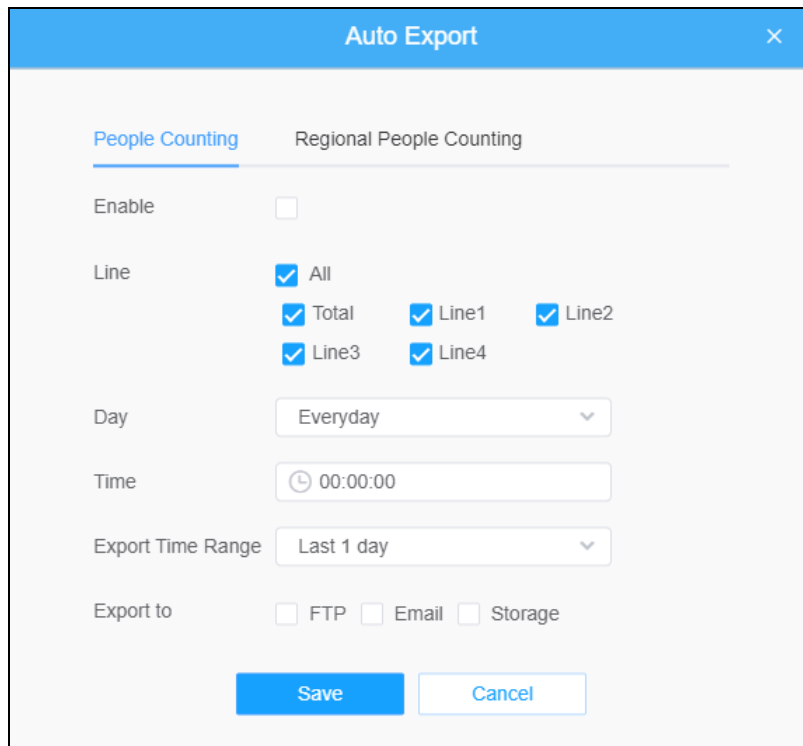
**[Regional People Counting-Export]**



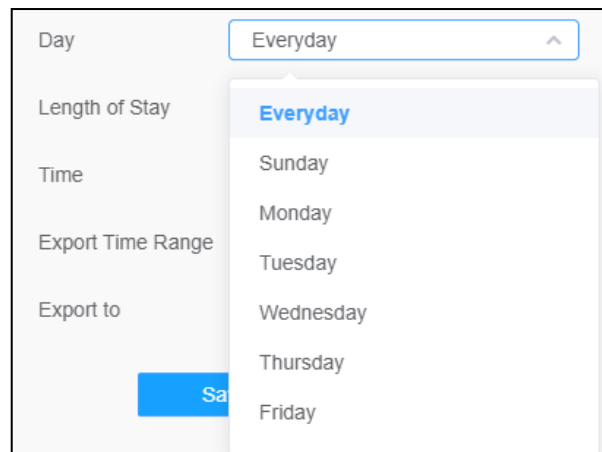
**Step8:** Click **Auto Export** to pop up the Statistics Report Settings as shown below.



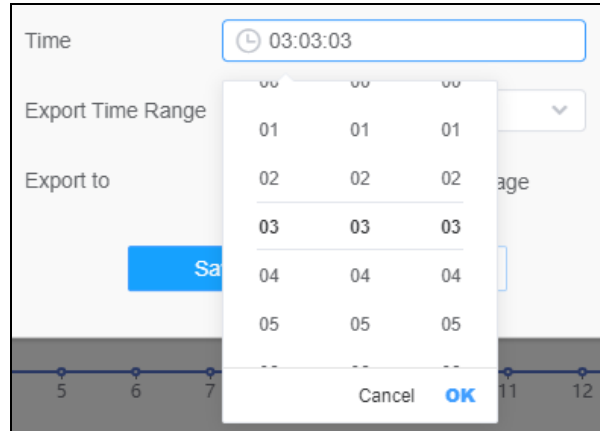
## [People Counting-Auto Export]



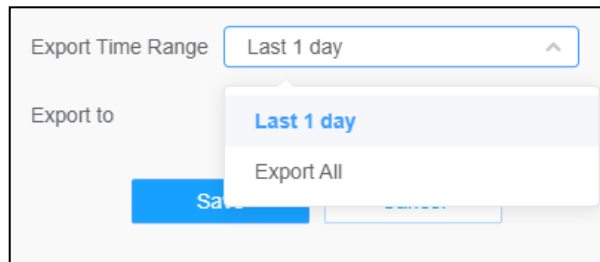
- Check the check box to enable the auto export of People Counting, then select the lines as needed.
- Set **Day**. Choose **Everyday** to export daily reports, or choose other options to export reports on a specific day of the week;



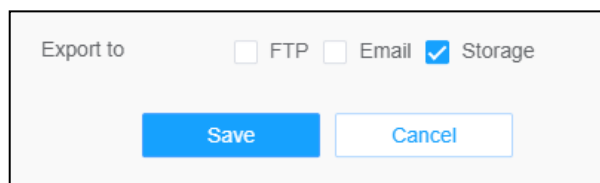
- Set **Time**. User can choose the time of day to export the Statistics Report automatically, click the calendar icon to pop up the following Quick Selection;



- Set **Export Time Range**;

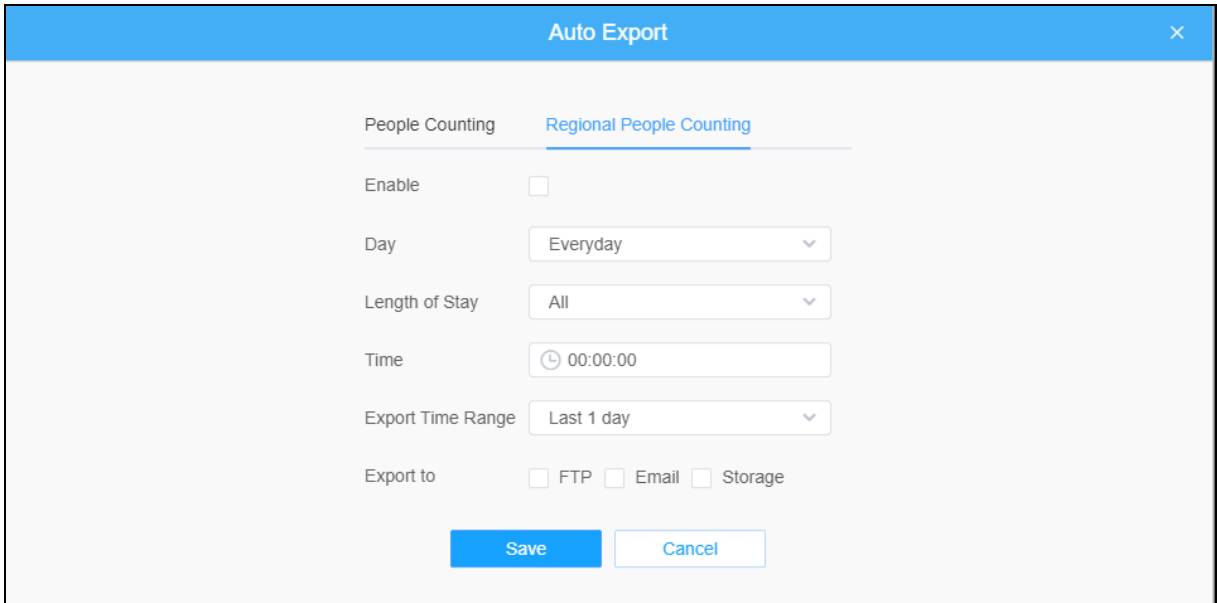


- Set the destination path of the automatically exported report. The report can be exported to FTP/ Email/Storage automatically as the form of an Excel spreadsheet according to the day, time and export time range previously set. Then click **Save**.



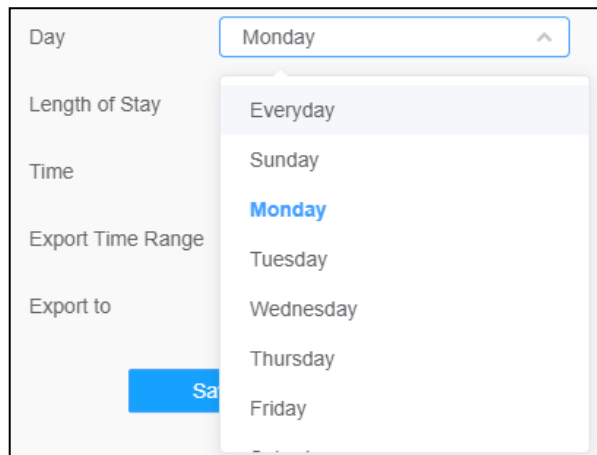
**Note:** If the current Statistics Report is generated, it will be saved as a csv form.

**[Regional People Counting-Auto Export]**



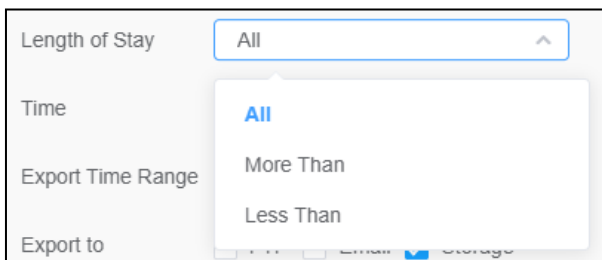
The screenshot shows the 'Auto Export' configuration window. At the top, it says 'Auto Export' with a close button. Below that, there's a section for 'People Counting' with a sub-section 'Regional People Counting'. There are several settings: 'Enable' (checkbox), 'Day' (dropdown menu set to 'Everyday'), 'Length of Stay' (dropdown menu set to 'All'), 'Time' (input field with a clock icon set to '00:00:00'), 'Export Time Range' (dropdown menu set to 'Last 1 day'), and 'Export to' (checkboxes for 'FTP', 'Email', and 'Storage'). At the bottom, there are 'Save' and 'Cancel' buttons.

- Check the check box to enable the auto export of Regional People Counting.
- Set **Day**. User can choose **Everyday** to export daily reports, or choose other options to export reports on a specific day of the week;



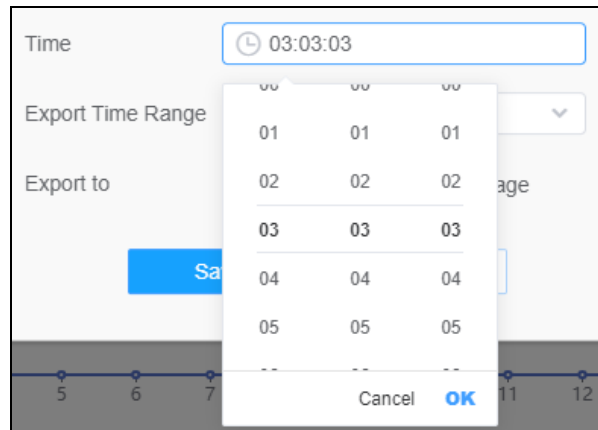
This close-up shows the 'Day' dropdown menu. The current selection is 'Monday'. The dropdown list includes 'Everyday', 'Sunday', 'Monday' (highlighted in blue), 'Tuesday', 'Wednesday', 'Thursday', and 'Friday'. A 'Save' button is partially visible at the bottom left.

- Set **Length of Stay**.

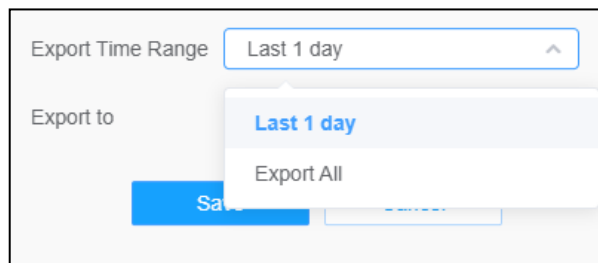


This close-up shows the 'Length of Stay' dropdown menu. The current selection is 'All'. The dropdown list includes 'All' (highlighted in blue), 'More Than', and 'Less Than'. Other settings like 'Time', 'Export Time Range', and 'Export to' are partially visible in the background.

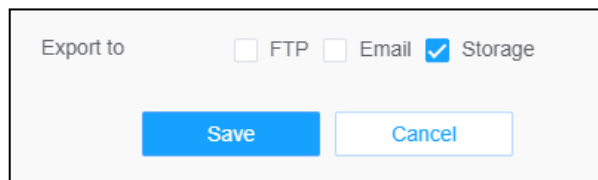
- **Set Time.** User can choose the time of day to export the Statistics Report automatically, click the calendar icon to pop up the following Quick Selection;



- **Set Export Time Range;**



- **Set the destination path of the automatically exported report.** The report can be exported to FTP/ Email/Storage automatically as the form of an Excel spreadsheet according to the day, time and export time range previously set. Then click **Save**.



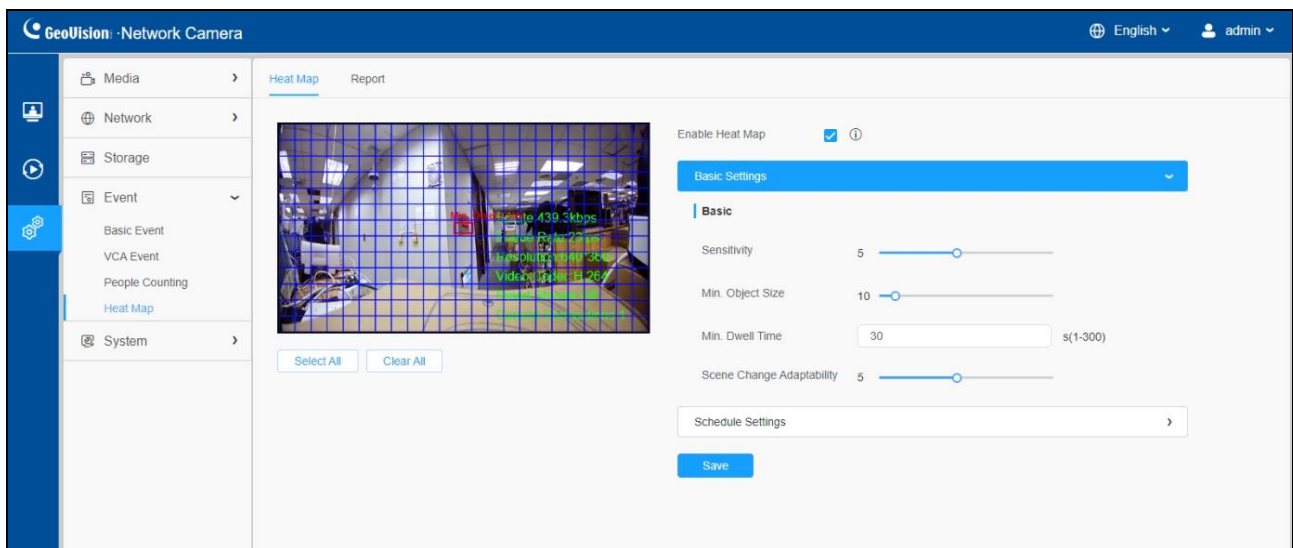
**Note:** If the current Statistics Report is generated, it will be saved as a csv form.

## 8.4.4 Heat Map

### 8.4.4.1 Heat Map

Heat Map function can analyze customers movement to reveal insights for better business management with the intuitive and accurate statistical analysis results in time or space pattern as needed.

**Note:** Only allowed to view reports within 7 days without a SD card or NAS.



**Step 1:** Enable Heat Map function.

**[Basic Settings]**

Enable Heat Map

Basic Settings ▼

**Basic**

Sensitivity 5

Min. Object Size 10

Min. Dwell Time  s(1-300)

Scene Change Adaptability 5

Schedule Settings >

Save

**Table 52. Description of the buttons**

Parameters	Function Introduction
<b>Sensitivity</b>	Level 1~10 is available, the default level is 5. The higher the sensitivity, the easier it is for moving objects to be recorded in the results.
<b>Min. Object Size</b>	Set the minimum object size from 1 to 100, the default value is 10. Objects smaller than this value will not be recorded in the result.
<b>Min. Dwell Time</b>	Set the minimum dwell time from 1 to 300, the default value is 30. If the object stays in the area longer than the set "Minimum Dwell Time", it will not be recorded in the result.
<b>Scene Change Adaptability</b>	Level 1~10 is available, the default level is 5. Scene Change Adaptability indicates the camera's adaptability to scene changes, which can increase the accuracy of detection. The camera adapts to faster changing scenes better if the value is higher.

**Step 2:** Set Heat Map Region. Draw the screen to set the detection area. You can click “**Select All**” button to select all areas, or “**Clear All**” button to remove the current drawn area.

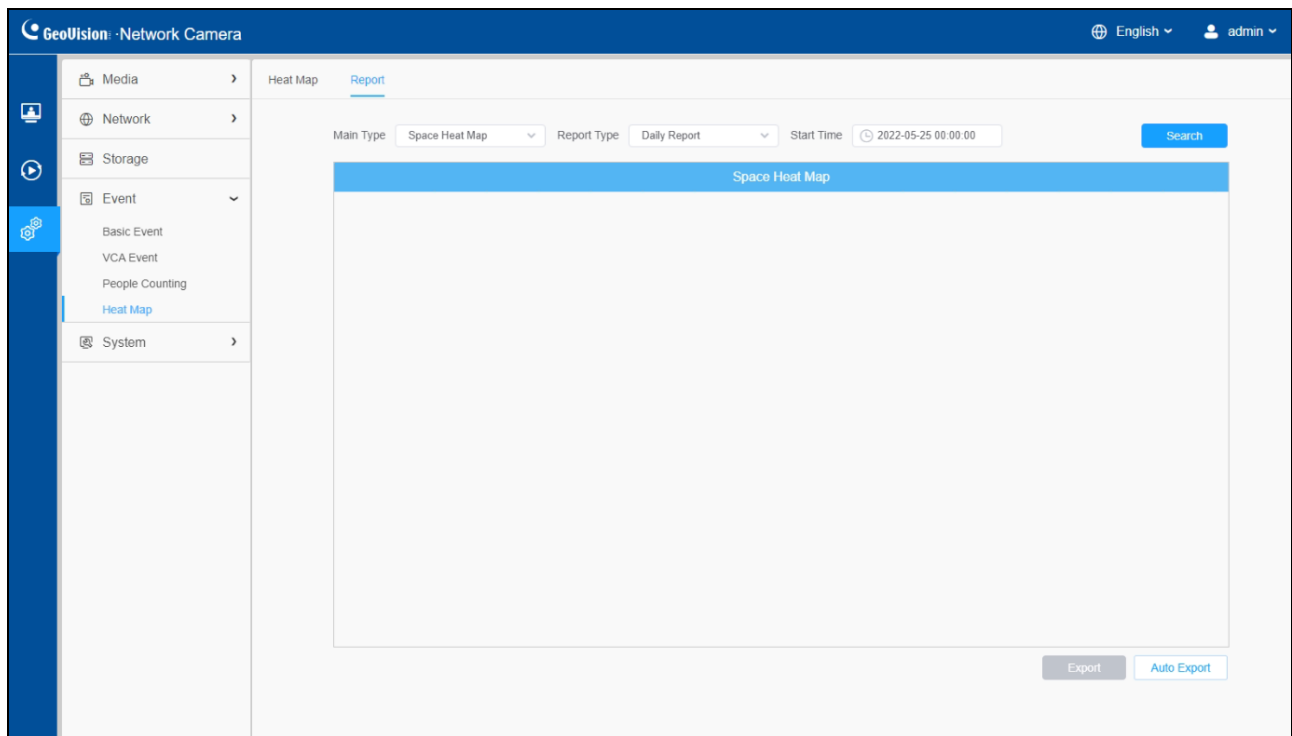
### [Schedule Settings]

**Step3:** Schedule Settings.

**Note:** Refer to Table 41 of 8.5.2.1 *Region Entrance* for details.

#### 8.4.4.2 Report

The heat map results will be displayed on this interface.



**Step 1:** Select **Main Type** for Heat Map.

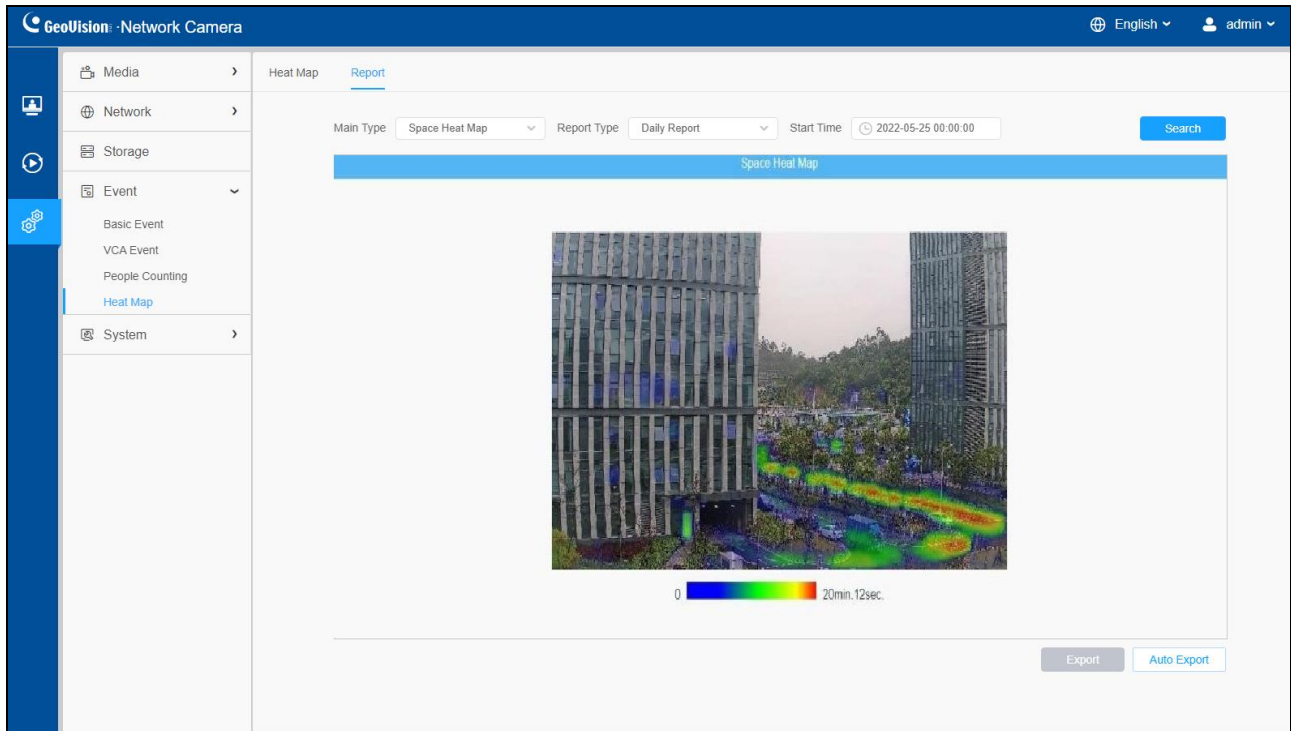
**[Space Heat Map]:** Space Heat Map will be presented as a picture with different colors. Different colors represent different heat values. Red represents the highest and blue represents the lowest.

**[Time Heat Map]:** Time Heat Map will be presented as a line chart to show the heat at different times.

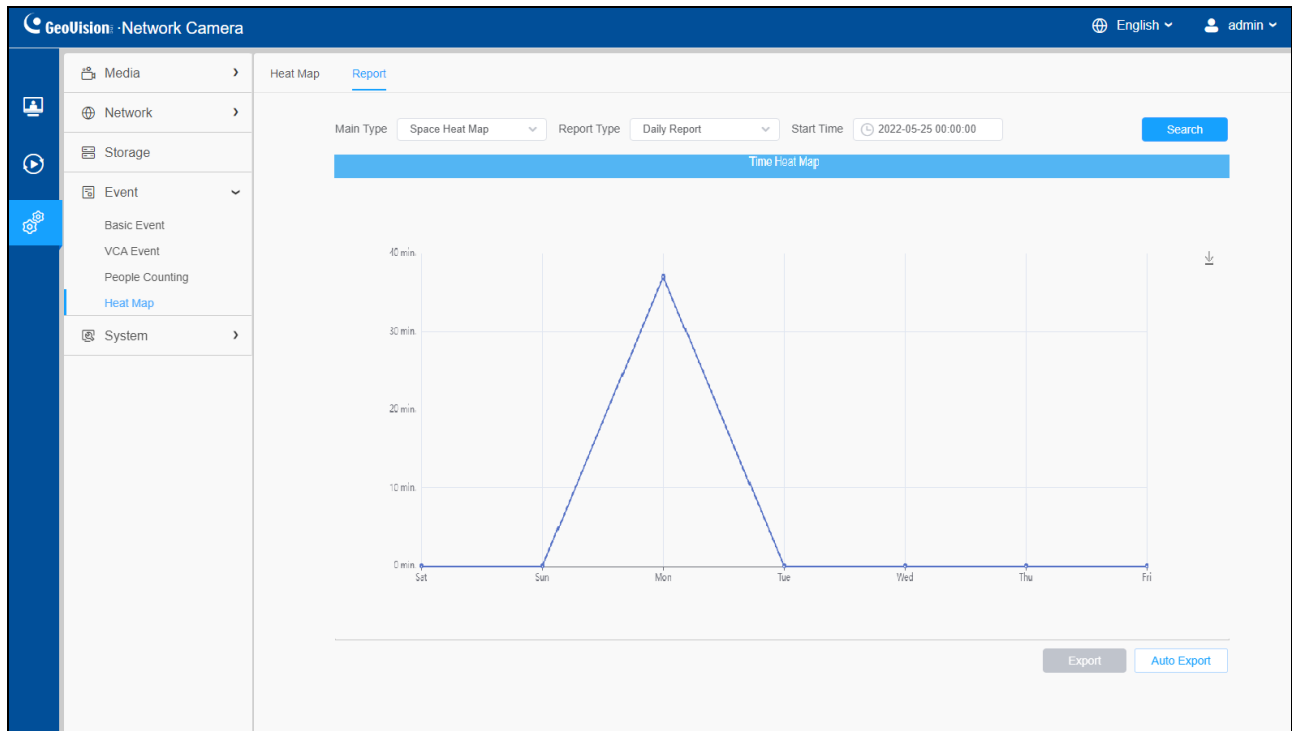
**Step 2:** Select **Report Type**, including **Hourly Report**, **Daily Report**, **Weekly Report**, **Monthly Report** and **Annual Report**.

**Step 3:** Select **Start Time**, then click the “**Search**” button, the camera will automatically count the data for the hour/day/ week/ month/ year (based on the report type selected) from the start time and generate the corresponding report as shown below.

## [Space Heat Map]



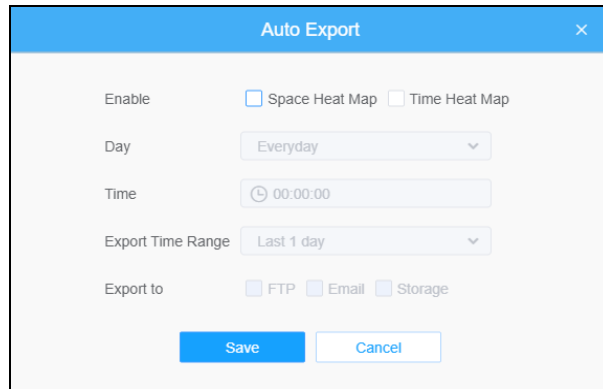
## [Time Heat Map]



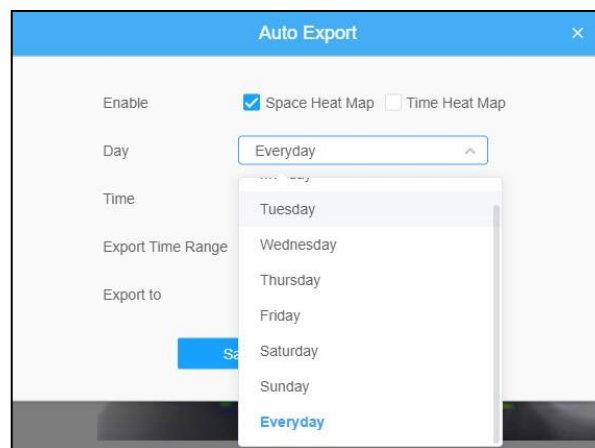
**Step 4:** Click the "Export" button to export the report locally.



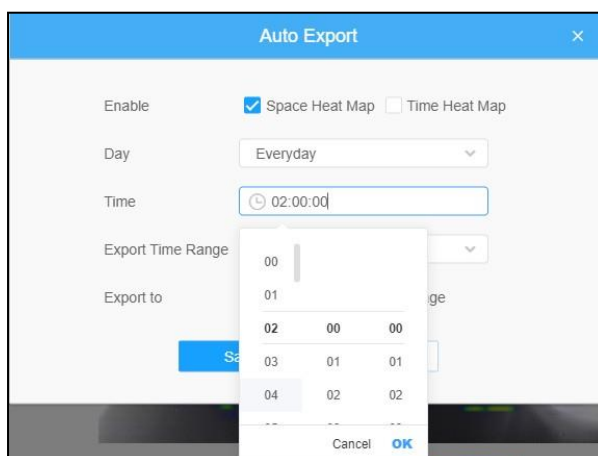
**Step 5:** Click the "Auto Export" button to pop up the Heat Map Report Settings as shown below.



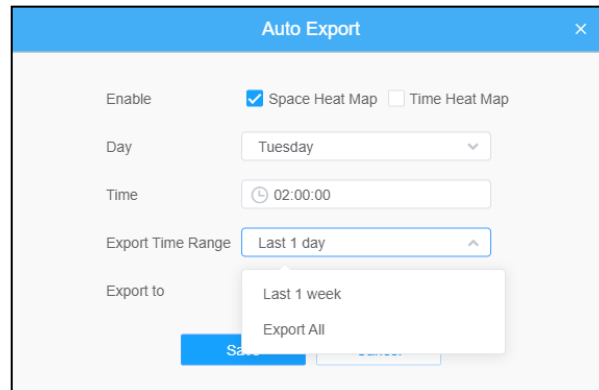
- Set **Export Type**. User can check **Space Heat Map** or **Time Heat Map** or both. When either **Space Heat Map** or **Time Heat Map** is checked, the gray item becomes editable as shown below;
- Set **Day**. User can choose **Everyday** to export daily reports, or choose other options to export reports on a specific day of the week;



- Set **Time**. User can choose the time of day to export the heat map automatically, click the calendar icon to pop up the following Quick Selection;

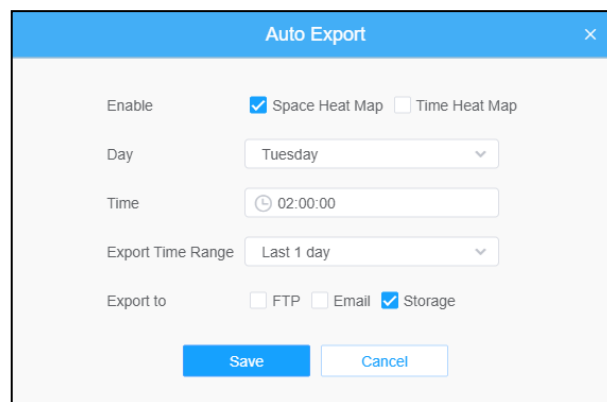


- **Set Export Time Range.**



The screenshot shows the 'Auto Export' dialog box with the following settings: 'Enable' has 'Space Heat Map' checked and 'Time Heat Map' unchecked; 'Day' is set to 'Tuesday'; 'Time' is set to '02:00:00'; 'Export Time Range' is set to 'Last 1 day'; and the 'Export to' dropdown menu is open, showing 'Last 1 week' and 'Export All' as options. A 'Save' button is partially visible at the bottom.

- Set the destination path of the automatically exported report. The report can be exported to FTP/ Email/Storage automatically as the form of an Excel spreadsheet or a picture according to the day, time and export time range previously set. Then click **“Save”**.



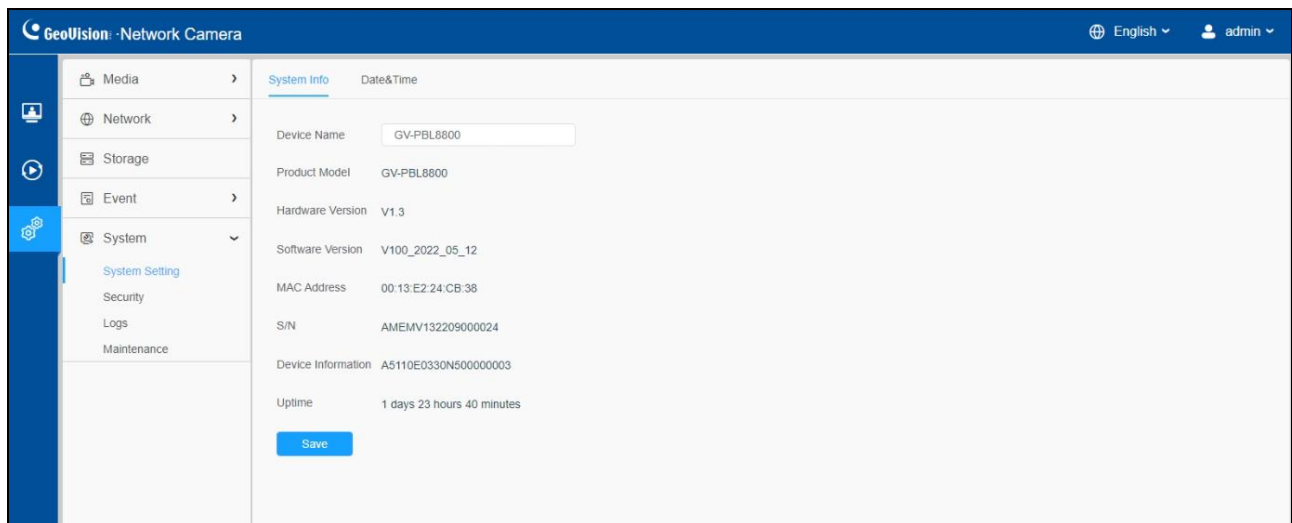
The screenshot shows the 'Auto Export' dialog box with the following settings: 'Enable' has 'Space Heat Map' checked and 'Time Heat Map' unchecked; 'Day' is set to 'Tuesday'; 'Time' is set to '02:00:00'; 'Export Time Range' is set to 'Last 1 day'; and 'Export to' has 'Storage' checked, while 'FTP' and 'Email' are unchecked. The 'Save' button is highlighted in blue.

If the current Space Heat Map is generated, it will be saved as a png image. If the current Time Heat Map is generated, it will be saved as a csv form.

## 8.5 System

### 8.5.1 System Setting

#### 8.5.1.1 System info

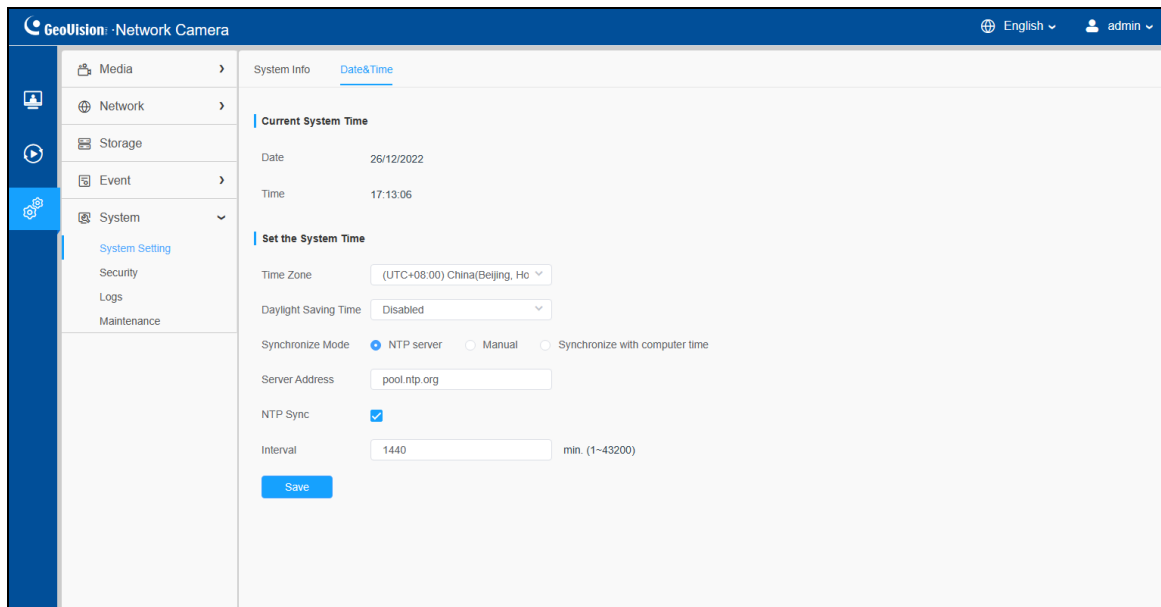


**Table 53. Description of the buttons**

Parameters	Function Introduction
<b>Device Name</b>	The device name can be customized. It will be seen in file names of video files.
<b>Product Model</b>	The product model of the camera.
<b>Hardware Version</b>	The hardware version of the camera.
<b>Software Version</b>	The software version of the camera can be upgraded.
<b>MAC Address</b>	Media Access Control address.
<b>S/N</b>	Stock Number.

<b>Device Information</b>	The device information.
<b>Uptime</b>	The elapsed time since the last restarted of the device.
<b>Save</b>	Save the configuration.

### 8.5.1.2 Date&Time

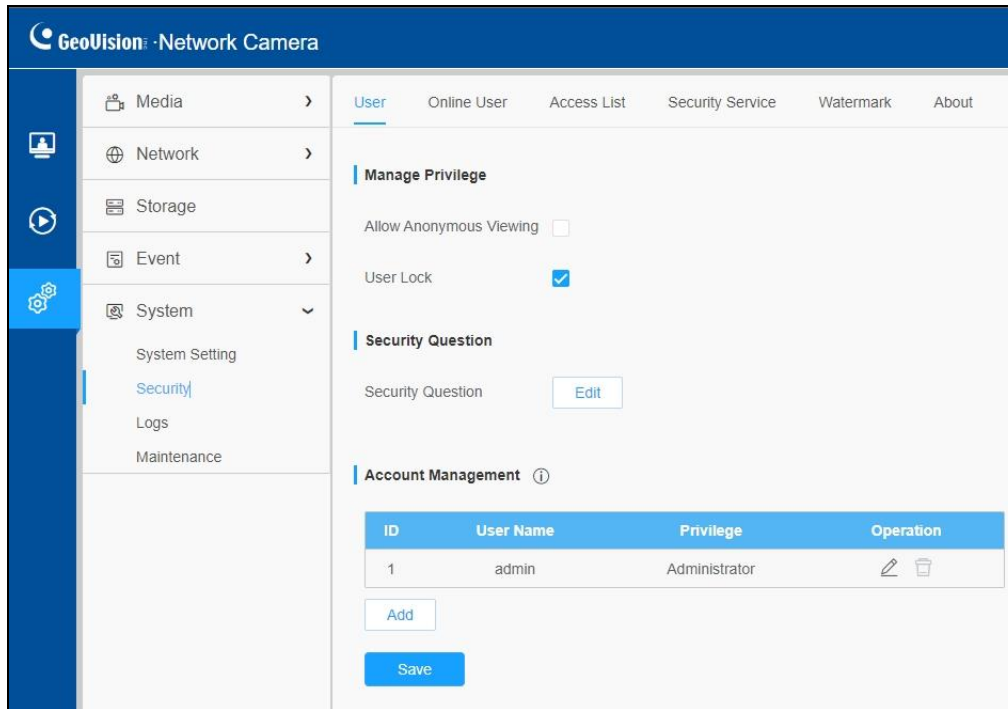


**Table 54. Description of the buttons**

Parameters	Function Introduction
<b>Current System Time</b>	Current date & time of the system.
<b>Set the System Time</b>	<p><b>Time Zone:</b> Choose a time zone for your location.</p> <p><b>Daylight Saving Time:</b> Enable the daylight saving time.</p> <p><b>Synchronize Mode:</b> <b>NTP server</b>, <b>Manual</b> and <b>Synchronize with computer time</b> are optional.</p> <p><b>Server Address:</b> Input the address of NTP server (only required when <b>NTP Server</b> is selected <b>Synchronize Mode</b>).</p> <p><b>NTP Sync:</b> Regularly update your time according to the interval time.</p> <p><b>Interval:</b> Only required when <b>NTP Server</b> is selected for <b>Synchronize Mode</b>.</p>
<b>Save</b>	Save the configuration.

## 8.5.2 Security

### 8.5.2.1 User



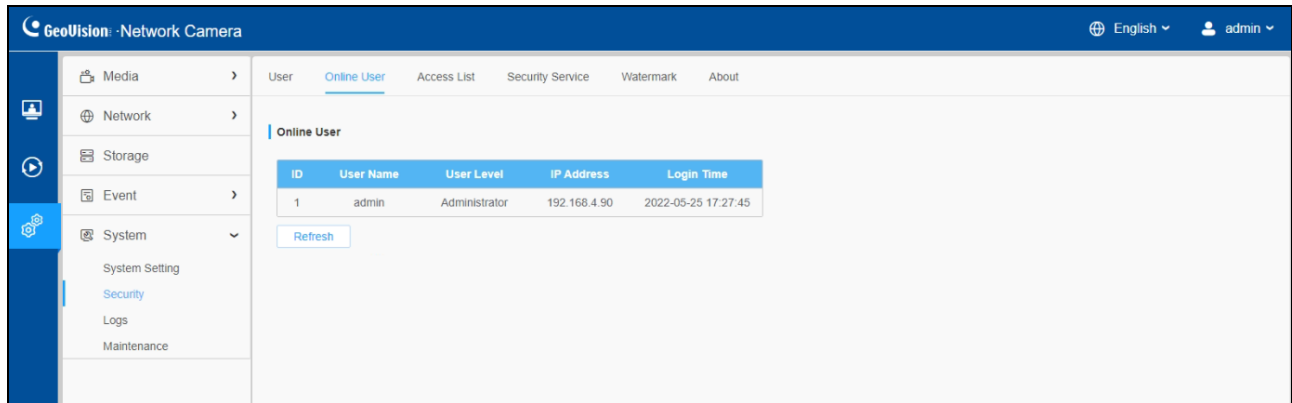
**Table 55. Description of the buttons**

Parameters	Function Introduction
<b>Manage Privilege</b>	<p><b>Allow Anonymous Viewing:</b> Check the checkbox to enable visit from whom doesn't have account of the device.</p> <p><b>User Lock:</b> This function is enabled by default. Check/uncheck the checkbox to enable/disable an automatic account lockout for 30 minutes after 3 failed login attempts when incorrect passwords are entered.</p>


<p style="text-align: center;"><b>Security Question</b></p>	<p>Click <b>“Edit”</b> button to set three security questions for your camera. In case that you forget the password, you can click <b>“Forget Password?”</b> button on login page to reset the password by answering three security questions correctly.</p> <div data-bbox="532 382 1333 1035" style="border: 1px solid #ccc; padding: 10px; background-color: #f9f9f9;"> <div style="background-color: #0070c0; color: white; padding: 5px; display: flex; justify-content: space-between; align-items: center;"> <span>Security Question Settings</span> <span>×</span> </div> <div style="margin-top: 10px;"> <p>Admin Password* <input type="password"/></p> <p>Security Question1 <input type="text" value="What's your father's name?"/></p> <p>Answer1* <input type="text"/></p> <p>Security Question2 <input type="text" value="What's your father's name?"/></p> <p>Answer2* <input type="text"/></p> <p>Security Question3 <input type="text" value="What's your father's name?"/></p> <p>Answer3* <input type="text"/></p> <div style="display: flex; justify-content: center; gap: 20px; margin-top: 10px;"> <input type="button" value="Save"/> <input type="button" value="Cancel"/> </div> </div> </div> <p>There are twelve default questions. You can also customize the security questions.</p>
<p style="text-align: center;"><b>Account Management</b></p>	<p>Click <b>“Add”</b> button, a pop-up window will appear. You can add an account to the camera by filling in <b>Admin Password, User Level, User Name, New Password, Confirm</b>, and edit user privilege by checking the check boxes below. The added account will be displayed in the account list.</p> <p><b>Admin Password:</b> You can add an account only after you enter the correct admin password.</p> <p><b>User Level:</b> Set the privilege for the account.</p> <p><b>User Name:</b> Input user name for creating an account.</p> <p><b>New Password:</b> Input password for the account.</p> <p><b>Confirm:</b> Confirm the password.</p> <p>You can edit and delete the account in the account list under the admin account. For the default admin account, you can only change the password, and it cannot be deleted.</p> <p><b>Note:</b></p> <ul style="list-style-type: none"> <li>• Support up to 20 users, including a default user and 19 custom added users.</li> <li>• The operator privilege is all checked by default.</li> </ul>

### 8.5.2.2 Online User

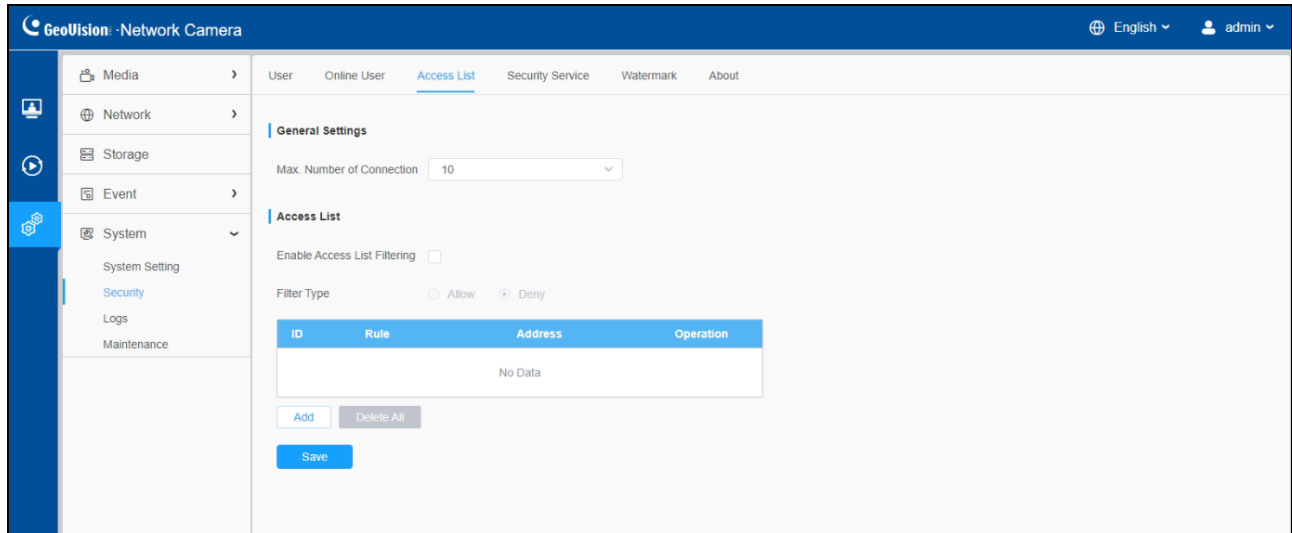
Here real-time status of user logging in camera will be shown.





**Table 56. Description of the buttons**

Parameters	Function Introduction
<b>Refresh</b>	Click to get latest status of user accessing to camera.
<b>ID</b>	Record serial number of user logging in camera. <b>Note:</b> <ul style="list-style-type: none"> <li>• There are at most 30 records shown at the list.</li> <li>• There is only one record if the same user logging on camera by the same IP address.</li> </ul> 
<b>User Name</b>	Name of user logging in camera.
<b>User Level</b>	Level of user logging in camera.
<b>IP Address</b>	Device IP address where user logging in camera web located.
<b>Login Time</b>	Camera system time of user logging in camera.

### 8.5.2.3 Access List

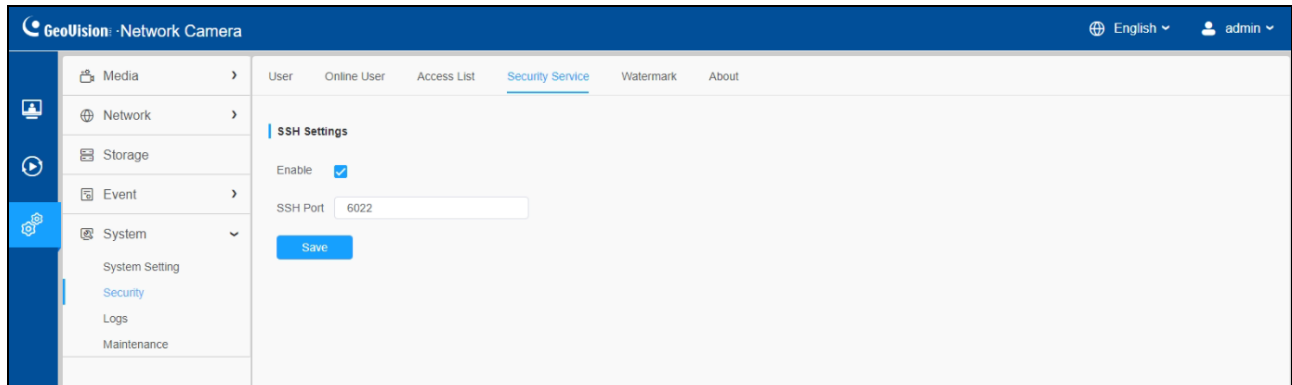


**Table 57. Description of the buttons**

Parameters	Function Introduction
<b>General Settings</b>	<b>Max. Number of Connection:</b> Select the maximum number of concurrent streaming. Options include No Limit, 1~10.
<b>Access List</b>	<p><b>Enable Access List Filtering:</b> Able to access or restrict access for some IP address.</p> <p><b>Filter type:</b> Allow or deny access.</p> <p><b>Add: Rule: Single, Network and Range</b> are available.</p> <p><b>IP address:</b> Input the address to get the access to the device.</p> <p><b>Delete All:</b> Delete all the access list.</p> <p><b>Edit</b>  : Edit the selected IP on access list.</p> <p><b>Delete</b>  : Delete the selected IP on access list.</p>
<b>Save</b>	Save the configuration.



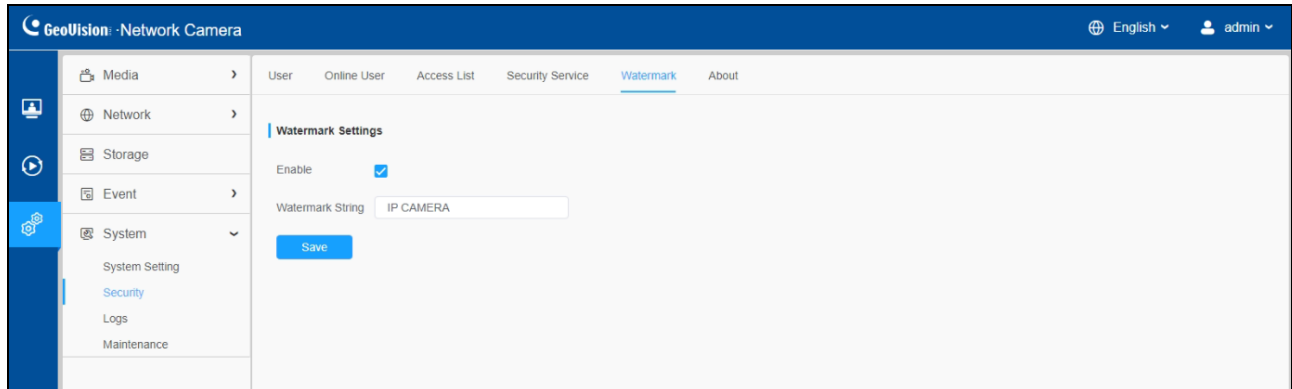
### 8.5.2.4 Security Service



**Table 58. Description of the buttons**

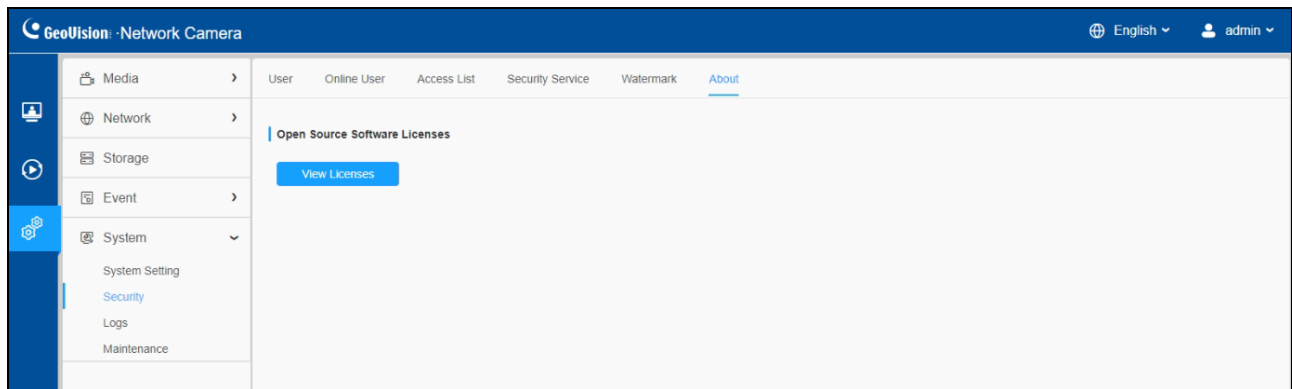
Parameters	Function Introduction
<b>SSH Settings</b>	Secure Shell (SSH) has many functions: It can replace Telnet and also provides a secure channel for FTP, POP, even for PPP.

### 8.5.2.5 Watermark



Watermarking is an effective method to protect information security, realizing anti-counterfeiting traceability and copyright protection.

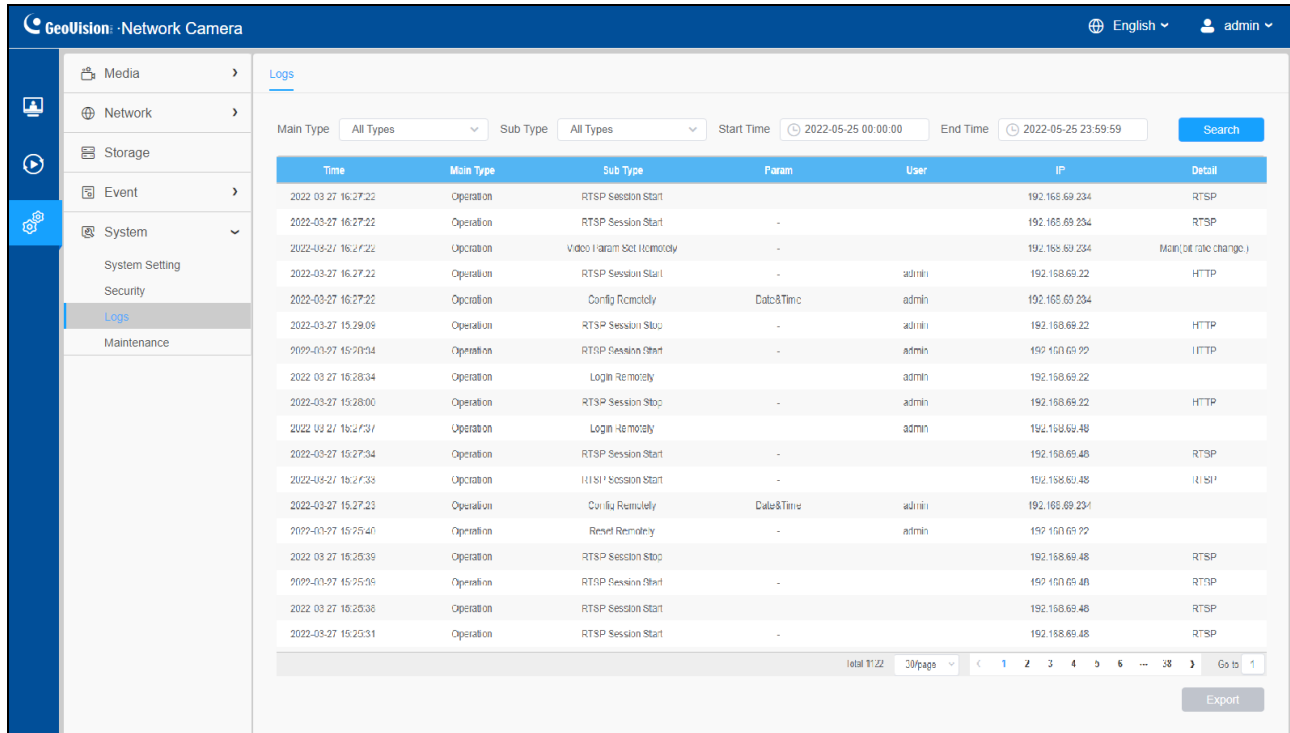
### 8.5.2.6 About



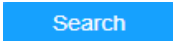

User can view some open source software licenses about the camera by clicking the View Licenses button.

### 8.5.3 Logs

The logs contain the information about the time and IP that has accessed the camera through web.

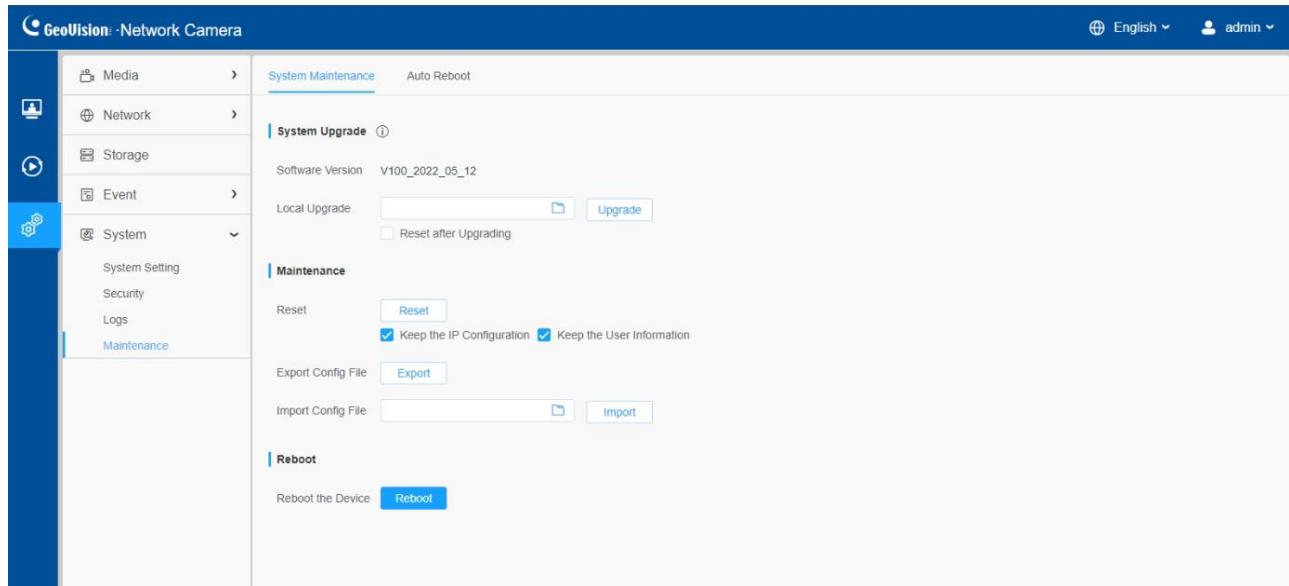


**Table 59. Description of the buttons**


Parameters	Function Introduction
<b>Main Type</b>	There are five main log types: <b>All Type</b> , <b>Event</b> , <b>Operation</b> , <b>Information</b> , <b>Exception</b> and <b>Smart</b> .
<b>Sub Type</b>	On the premise that main type has been selected, select the sub type to narrow the range of logs.
<b>Start Time</b>	The time log starts.
<b>End Time</b>	The time log ends.
	Search the logs.
	Export the logs.
<b>Go to</b>	Input the number of logs' page.


## 8.5.4 Maintenance

### 8.5.4.1 System Maintenance

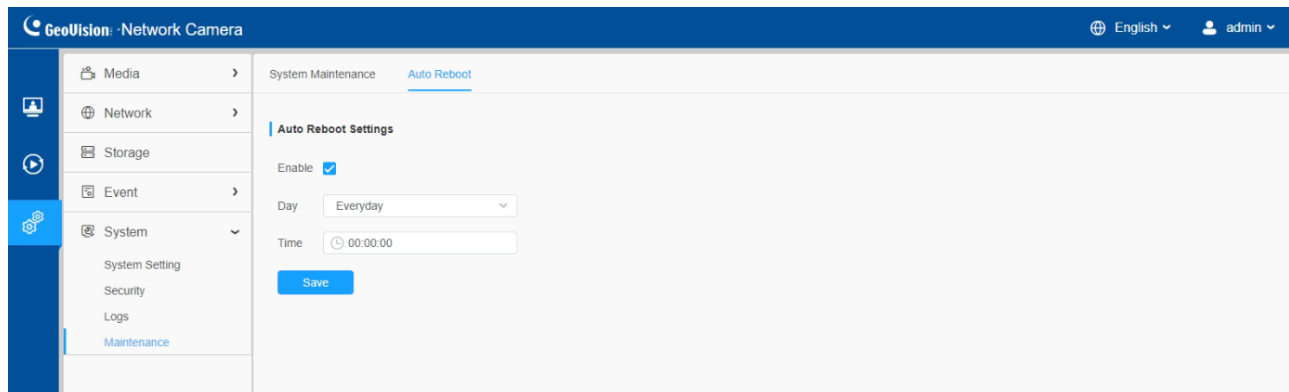


**Table 60. Description of the buttons**

Parameters	Function Introduction
<p><b>System Upgrade</b></p>	<p><b>Software Version:</b> The software version of the camera.</p> <p><b>Local Upgrade:</b> Click the “Browse” button  and select the upgrading file. Then click the “<b>Upgrade</b>” button to upgrade. After the system reboots successfully, the update is done.</p> <p>You can check “<b>Reset after Upgrading</b>” to reset the camera after upgrading it.</p> <p><b>Note:</b> Do not disconnect the power of the device during the update. The device will be restarted to complete the upgrading.</p>

<b>Maintenance</b>	<p><b>Reset:</b> Click “<b>Reset</b>” button to reset the camera to factory default settings.</p> <p><b>Keep the IP Configuration:</b> Check this option to keep the IP configuration when resetting the camera.</p> <p><b>Keep the User information:</b> Check this option to keep the user information when resetting the camera.</p> <p><b>Export Config File:</b> Click this button and a window will pop up.</p> <p>You need to enter and confirm password again, then click save button to export configuration file.</p> <p><b>Import Config File:</b> Click the “Browse” button , then a window will pop up and you can click "OK" to update the configuration.</p> <p>It will pop up a window to prompt "Input the password of config file", then enter password and click save button to import configuration file.</p> <p><b>Note:</b> Export and import the same configuration file. Password must be the same.</p>
<b>Reboot</b>	<p>Click “<b>Reboot</b>” button to restart the device immediately.</p>

### 8.5.4.2 Auto Reboot



Set the date and time to enable **Auto Reboot** function, and the camera will reboot automatically according to the customized time in case that camera overloads after running a long time.

# Appendix

## A. GV-Mount430

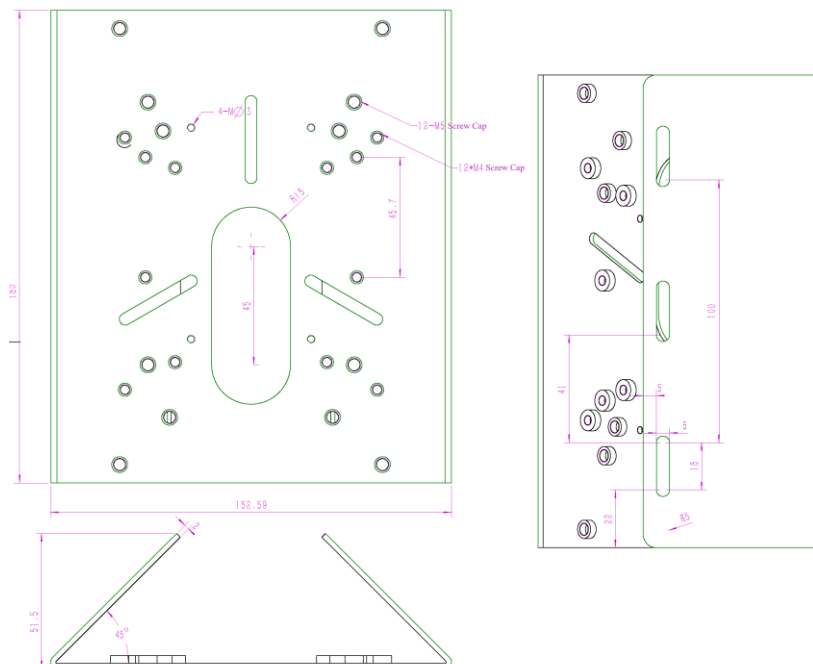


### GV-Mount430 Packing List

1. GV-Mount430	2. Steel Strap (Ø 102 ~ 107; 4.1" ~ 5") x 3
3. Plain Washer (Ø 6 x 18 x 1.5 mm) x 4	4. M4 Plain Washer (10 x 1 mm) x 4
5. M3 Screw (12 mm) x 3	6. M4 Screw (12 mm) x 4
7. M4 Screw (20 mm) x 4	8. M5 Screw (25 mm) x 4
9. M3 Screw Cap x 3	10. M4 Screw Cap x 4

### Dimension

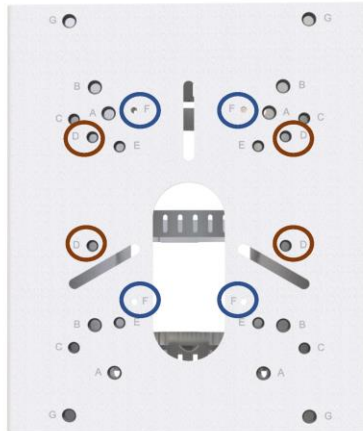
Unit: mm



### GV-Mount430 Installation

F: GV-PBL8800

D: GV-MOUNT211-5



### GV-Mount430 + GV-PBL8800

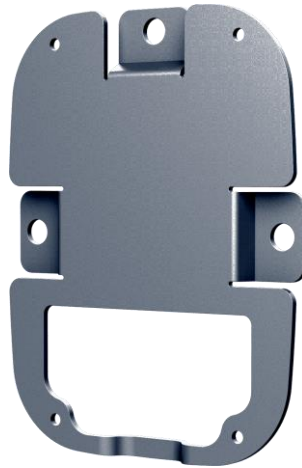


### GV-Mount430 + GV-Mount211-5 + GV-PDR8800



**Note:** It is required to use GV-Mount211-5 with GV-Mount430 to mount GV-PDR8800.

## B. GV-Mount923

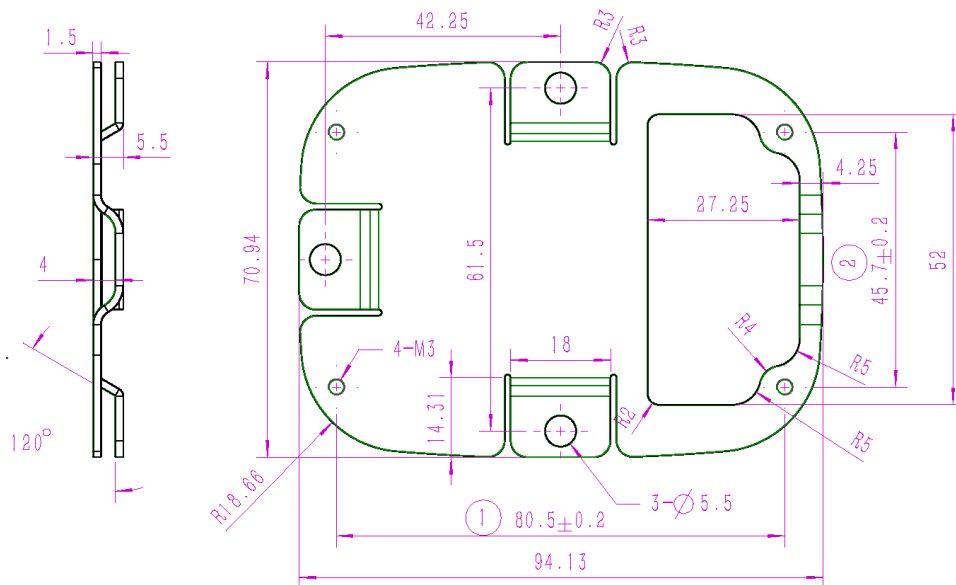


### GV-Mount923 Packing List

1. GV-Mount923	2. M3 Screw (8 mm) x 4
----------------	------------------------

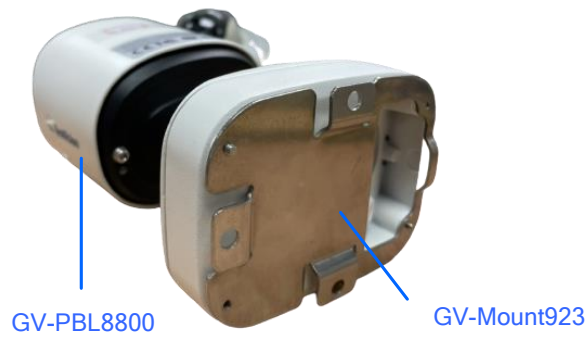
### Dimension

Unit: mm





### GV-Mount923 + GV-PBL8800



GV-Mount923 can be applied in special scenarios that require screws of larger size.

