

GV-B600LZ Brackets

The GV-B600LZ Brackets are required for installing the GV-ML600 electromagnetic lock on in-swing doors. The L bracket is used to mount the magnetic GV-ML600 lock body on the door frame above the door and the Z brackets attach the magnet faceplate to the door.

Packing List

1. L-Z Brackets for magnetic lock x 3



2. M8 (35 mm) screw + black rubber spacer x 1
3. M5 (5 mm) screw x 6



Note: To install the GV-B600LZ brackets, you will need to use the lock body, magnet faceplate, inner hexagon wrench and galvanized steel rivets, which are parts supplied with the GV-ML600 electromagnetic lock.

Dimensions

- L Bracket**

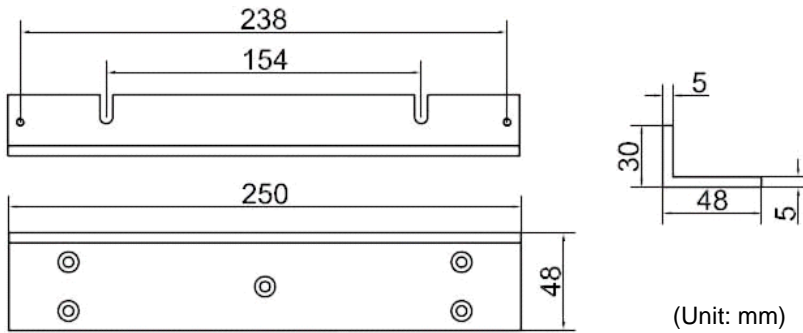

- Z Bracket (A)**

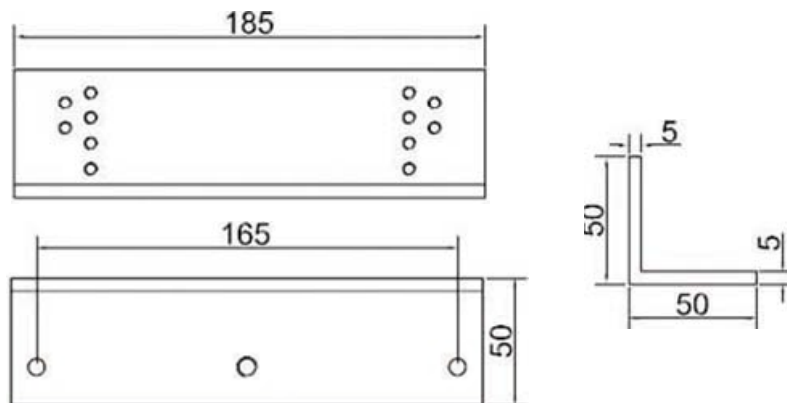

- Z Bracket (B)**

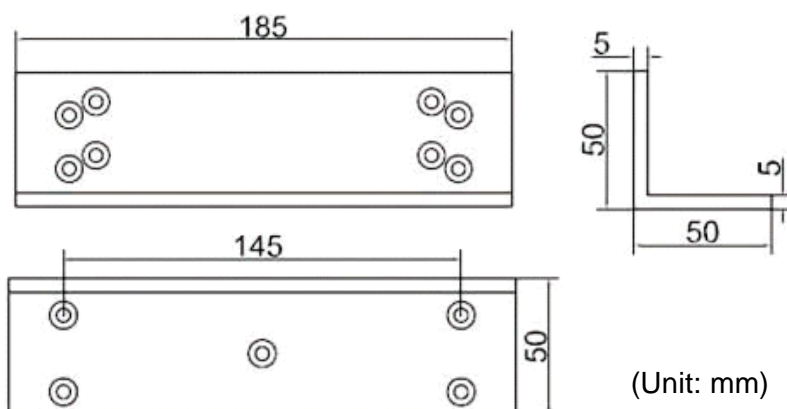

Installation

1. Attach the L bracket on the door frame above the door using four screws.

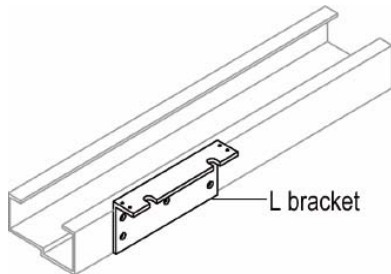

Note: You have to self-prepare the four screws.

2. Take the lock body from GV-ML600 electromagnetic lock, remove the two aluminum plugs on the side, and unscrew the screws inside.

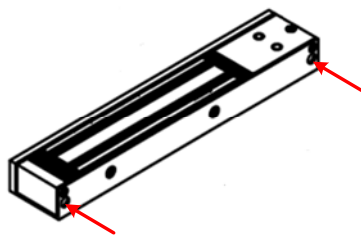

3. Remove the mounting plate from the lock body.

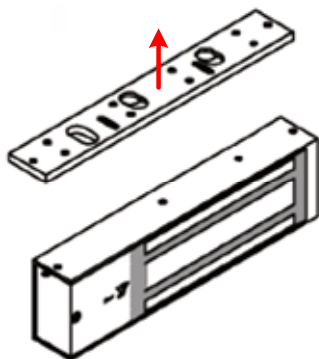

4. Attach the lock body to the L bracket and secure the mounting screws from step 2 using the inner hexagon wrench that comes with the GV-ML600.

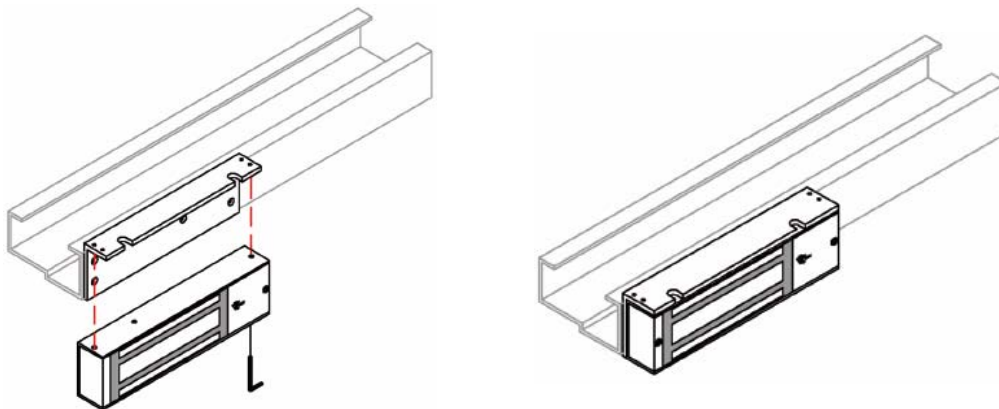

5. Place the two aluminum plugs back into the mounting screw holes.

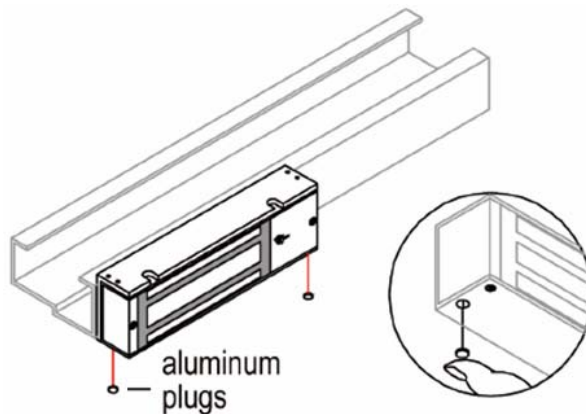

6. Mount Z bracket (B) onto the door by tightening four screws.

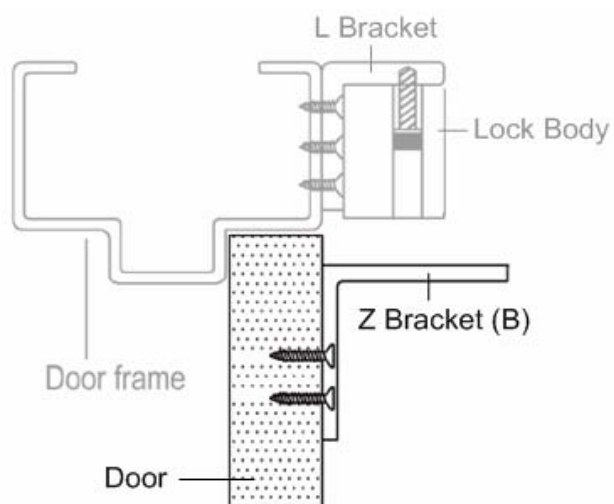

Note: You have to self-prepare the four screws.

7. Place the magnet faceplate from the GV-ML600 on the Z bracket (A) and insert the supplied M8 (35 mm) screw and black rubber spacer to the hole in the center. Insert the 2 galvanized steel rivets that come with the GV-ML600 toward the edges of the magnet faceplate.

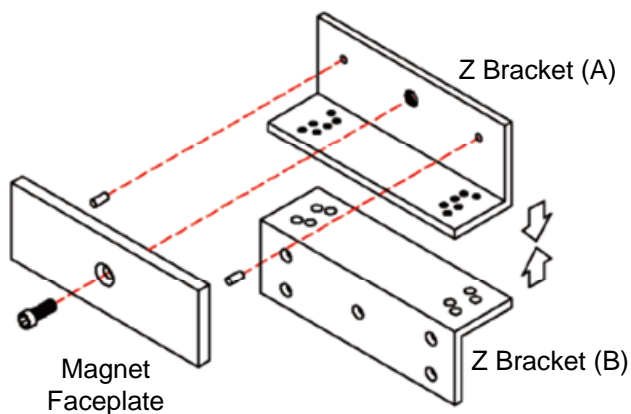

8. Place Z bracket (A) with the magnet faceplate on Z bracket (B) and insert the supplied M5 (5 mm) screws. Before tightening the screws, adjust the position of the Z brackets so that the magnet faceplate contacts the lock body.

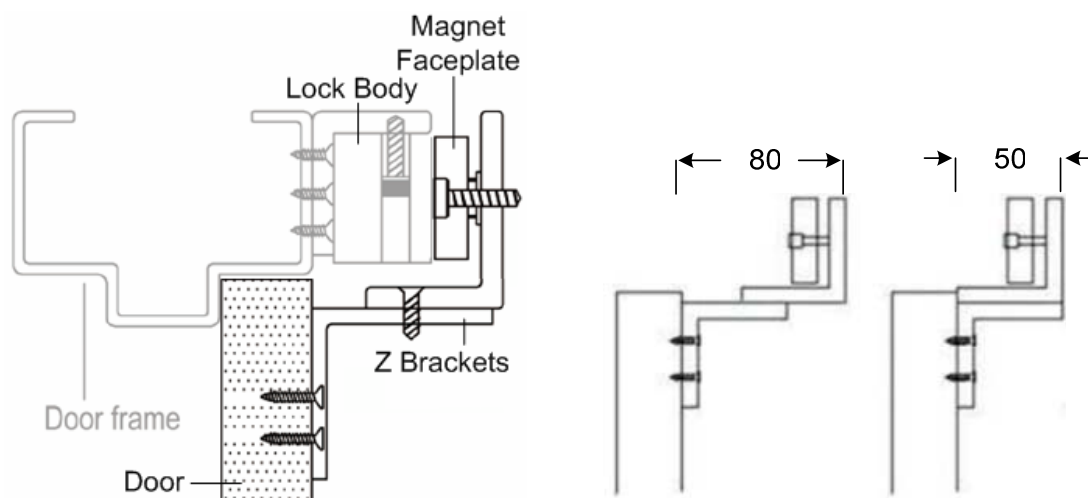

The L-Z brackets should look like the illustration below after installation is completed.

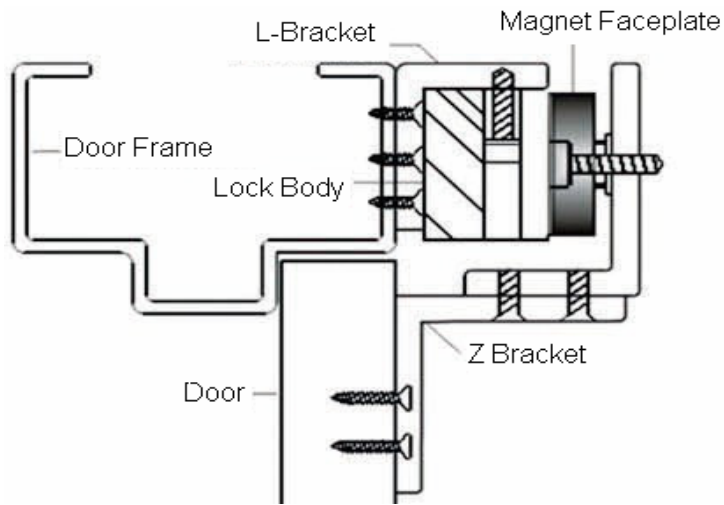

Specifications

Holding Force		272.15 kg (600 lb)
Dimensions (L x W x H)	L bracket	250 x 48 x 30 mm (9.8" x 1.9" x 1.2")
	Z bracket (x 2)	185 x 50 x 50 mm (7.3" x 2.0" x 2.0")
Weight (3 brackets)		750 g (1.65 lb)
Material		aluminum

All specifications are subject to change without notice.