

THIS COPY IS PROVIDED ON A RESTRICTED BASIS AND IS NOT TO BE USED IN ANY WAY DETRIMENTAL TO THE INTERESTS OF PANDUIT CORP.

TECHNICAL SPECIFICATIONS		
MAXIMUM LOSS		SINGLEMODE MAXIMUM LOSS
3.5 dB/KM @ 850nm 1.5 dB/KM @ 1300nm		.75 dB/KM @ 1310nm .75 dB/KM @ 1500nm
TENSILE LOAD - RISER RATED		
INSTALLATION		LONG TERM
2670 N (600 lbf)		890 N (200 lbf)
TEMPERATURE		
INSTALLATION	OPERATION	STORAGE
-30° C TO +60° C -22° F TO +140° F	-40° C TO +70° C -40° F TO +158° F	-40° C TO +75° C -40° F TO +167° F

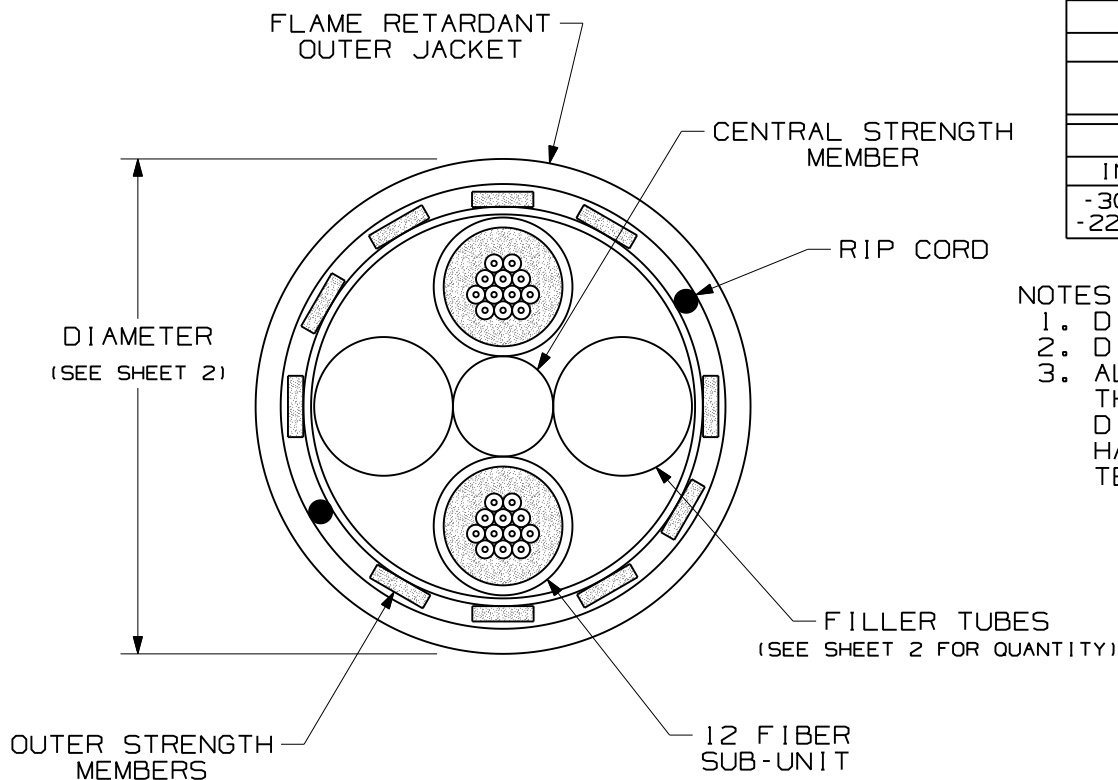

NOTES:

1. DIAMETER DIMENSION, SHOWN FOR REFERENCE ONLY.
2. DIMENSIONS IN BRACKETS () ARE ENGLISH.
3. ALL MATERIALS AND COMPONENTS USED MUST MEET THE MATERIAL RESTRICTIONS OF RoHS (EUROPEAN DIRECTIVE 2002/95/EC ON THE RESTRICTION OF HAZARDOUS SUBSTANCES) AS PROPOSED BY THE RoHS TECHNICAL ADAPTATION COMMITTEE.

REV	DATE	BY	CHK	DESCRIPTION	ECN	R	CUST	SUP	OTH
01	02-21-07	EFK		RELEASED TO PRODUCTION	02055-181				

OPTI-CORE 24 FIBER INDOOR-OUTDOOR CABLE
WITH (2) 12 FIBER SUB-UNITS
CUSTOMER DRAWING

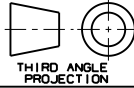

PANDUIT™
CORP.
TINLEY PARK, ILL 60477

 THIRD ANGLE PROJECTION	ALL DIMENSIONS ARE GIVEN IN INCHES, UNLESS OTHERWISE SPECIFIED. DIMENSIONAL TOLERANCES ARE: (.X) (.XXX) ±0.3 (.010) (.XX) ±0.8 (.03) ANGLES	DRAWING FILENAME M02055BZ_DC_24/00B SCALE NONE PART NO. FSN**24Y FON**24Y DRAWING NO. 02055-181 SHEET 1 OF 2 SIZE A
DRAWN BY EFK DATE 02-21-07 CHK'D WMA	REVIEW DRAWING NUMBERS	

