



IPSWD-RWB

IP Speaker with LED Display and Flashers

IP Speaker Overview

The IP Speaker is a Power over Ethernet (PoE, PoE+) synchronized clock and intercom that requires only an RJ-45 connector to connect to existing data networks. Simultaneously, broadcast to both phones and speakers. The clock auto synchronizes and can be used as a scrolling text display. Standard built in microphone and speaker for two way communication.

Capabilities

Timer/Stopwatch:

- Display 4 or 6 digits
- Configurable fonts and colors
- Count up or down
- Count days, hours, minutes, seconds, 1/100ths of seconds
- Display timer and clock simultaneously
- Event based trigger

Flashers:

- Configurable for emergencies or alerts
- Three individually controlled: one Red, one White, one Blue

Clock:

- 3" numbers/text
- Atomic time
- Never needs setting
- Auto-adjust for Daylight Savings
- Display 4 or 6 digits
- Configurable fonts and colors



Scrolling Text:

- Supports multiple types of messages:
- Custom Configuration
 - Reminders
 - Alerts
 - Advertising
 - RSS/Twitter/News/Weather/Stock feeds
 - Configurable fonts and colors
 - 1 or 2 Line Display

Microphone:

- Monitoring
- Two way talking/Intercom
- Paging Supervision
- Hands-free talk back

Auto Dimming:

Automatically dim for different times of day. Reduce power usage at night to save energy

Audio:

- 8" High efficiency PA Speaker
- Optional ancillary 8-ohm speaker
- Bell scheduling, reminders and alarms
- Clock chimes
- Voice paging from a PC or IP phone, scheduled or ad hoc
- Use provided notifications, alarms, audio files (sport, holiday, traditional, etc.), or your own

Features

Built in Web Server:

- Send text messages to the device from the web page
- Configurable brightness, fonts and volume
- Configurable NTP time server, time zone
- Device Status
- Field upgradable

Line In/ Out:

- Independent line-in.
- Can be configured to send line in audio to the speaker and/or add additional speakers

Easy Installation:

- Only requires CAT 5 connection (up to 300ft) to network
- Power over Ethernet (no power cord or adapter). No other equipment needed

GPIO:

- 2 inputs, 1 output
- Can be activated multiple ways including via telephone or programmatically.

Multicast:

- Full multicast and broadcast support. Send audio and/or scrolling text to individual, multiple, or all devices simultaneously.

Sound Masking:

- Generate configurable pink noise via push button or programmatically.

Two Way Communication:

- Activate via push button
- Allows for full duplex hands free communication
- Optional button for hand-free push to talk capability
- Interoperates with Cisco and other VoIP network and phones



Software Options

- AND devices can operate standalone and do not require external software for atomic timekeeping and sending text messages from the device's web server. However, application software can be used to take advantage of the device capabilities which can then be integrated into applications like mass notification system, a phone network, etc.
- **AND Clockwise: Developed and Supported by AND.** Instantly finds and provide controls for all of you AND devices. The software provides a clock/alarm feature that supports scheduling events, alarms, stopwatch, timer with an optional sound library. It also send News/RSS/Twitter/Weather/Stock feeds, etc. messages to AND devices with a display.
- **Third Party Software:** AND has had a long standing relationship with various third party software providers. AND devices support Informacast (Singlewire), SA-Announce (Syn-Apps), IPSession (IPCelerate), MessageNet Systems, BellComander (Acro Vista), and others. AND devices will work with SIP-compatible products/PBX, such as Asterisk, 3CX, ShoreTel, etc.
- **NOTE: AND Clockwise and 3rd Party Software can run concurrently**

Mounting Options

IPSWD-RWB comes with a separate back box. Choose from surface mount ([IPS-SM1](#)) or flush mount ([IPS-FM1](#)) options.

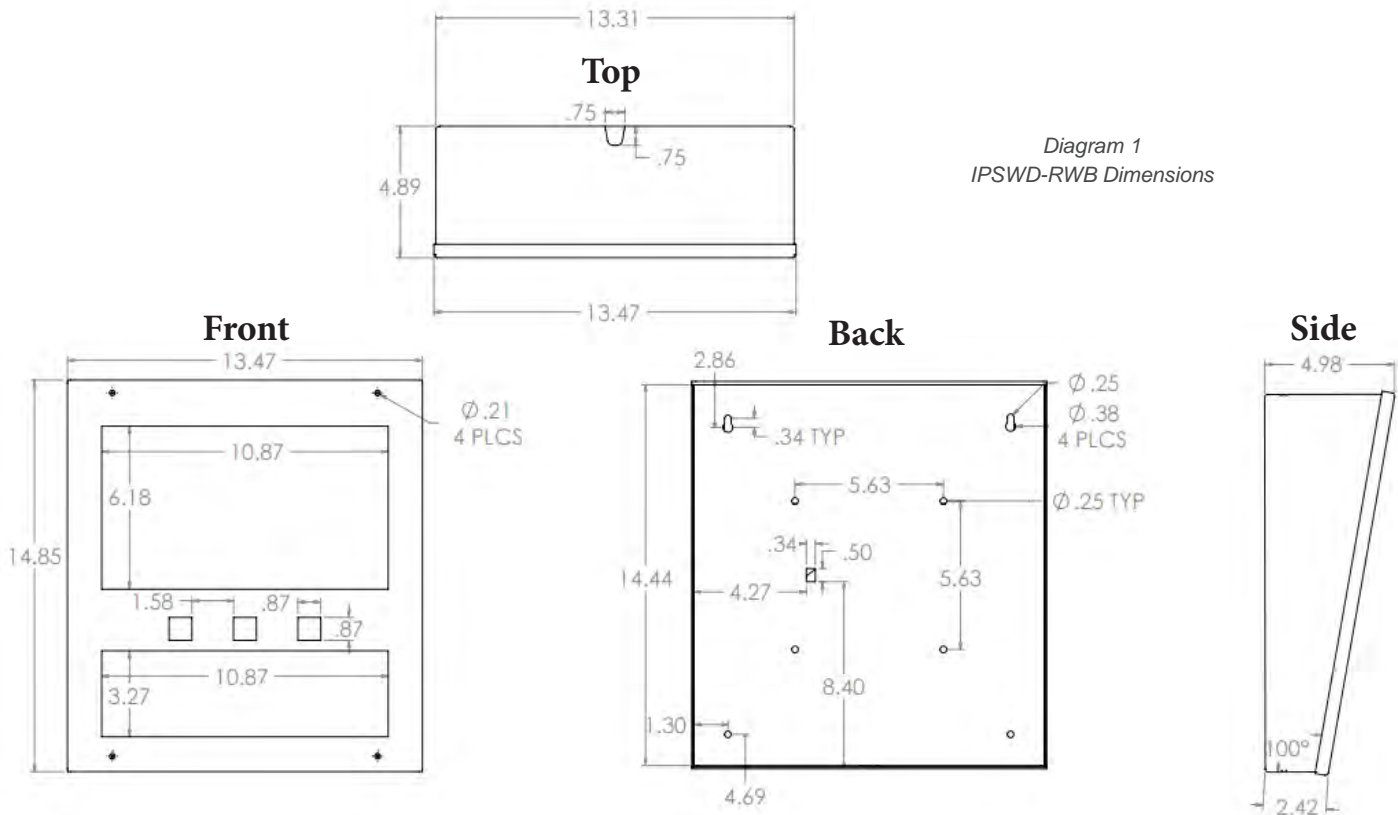

Specifications

- Weight: 8lbs
- Speaker Size: 8"
- Average Sensitivity: 95dB, 1W/1M
- Audio Power: 8 W/16 W
- Frequency Response: 60 Hz-17 kHz
- PoE (IEEE802.3af) 15.4 W or
- PoE+ (IEEE802.3at) 30.0 W
- 10/100 Mb network connection

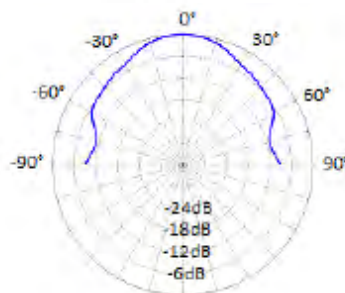

Diagram 2
8" Speaker Polar Plot
2 kHz Octave Band,
Grid Spacing = 6dB/Division

Supported Protocols

- | | |
|----------|------------|
| • SIP | • DHCP |
| • IPv4 | • IGMP |
| • HTTP | • ICMP |
| • SLP | • TCP/IP |
| • TFTP | • UDP |
| • NTP | • MDNS and |
| • SNMPV1 | MDNS-SD |
| & | |
| SNMPV2c | |

