

DESCRIPTION

The Verifact® BGC is an omni-directional, low impedance, electret condenser microphone with built-in preamp and automatic gain control. The microphone element is extended 3' for high ceiling applications. It can pick up normal sounds approximately 25 ft. away, or within a 50 ft. diameter circle. It's built-in limiter prevents the output signal to be overdriven thus minimizing distortion. Verifact® B-AGC produces line level output (0 dB) and can be located up to 1,000' from the Louroe base station. The microphone has a potentiometer to adjust the output gain up to +10dB. It is primarily designed for ceiling mounting but can also be installed on any type of flat surface. The Verifact® BGC is compatible with all Louroe Audio Base Stations or Louroe Audio Interface Adapters.



NOTE:

Verifact® BGC Microphone is NOT recommended for outdoor use or in areas with high moisture content.



SPECIFICATIONS

Microphone Sensitivity	-45dB
Frequency response	50Hz to 8kHz
Output	Line Level (0 dB, 1 kΩ at 1 KHz)
Current drain	10 mA
Supply voltage	12 Vdc
Microphone housing	High impact ABS
Dimensions	4" dia x 1 1/2" H
Weight	4 oz
Shipping Weight	1 lb

IMPORTANT NOTICE
 When this equipment is used as part of an audio monitoring system, the law requires that the public be given notice of AUDIO MONITORING ON THE PREMISES. A decal notice is included with each microphone shipped.



Federal Law References:
 Federal Regulations, US Code, Title 18.
 Crime and Criminal Procedure, Sec 2510.

WARRANTY

LOUROE ELECTRONICS® warrants that at the time of shipment products manufactured by LOUROE ELECTRONICS® to be free of defects in material and workmanship. Should a defect appear within one year (12 months) from date of shipment, LOUROE ELECTRONICS will, at its sole discretion, repair or replace the defective equipment. This equipment shall not be accepted for repair or return without prior notification by LOUROE ELECTRONICS®. This warranty does not extend to any Louroe product that has been subjected to improper or incorrect installation, misuse, accident, or in violation of installation instructions provided by LOUROE ELECTRONICS®. Returned shipments to LOUROE ELECTRONICS® shall be at customer's expense. LOUROE ELECTRONICS® will return the equipment prepaid via best way.

INSTALLATION AND OPERATING INSTRUCTIONS

ELECTRICAL CONNECTION:

The Verifact® BGC is cylindrical, 4" dia. x 1½" H, and has four mounting holes for surface mounting to a ceiling or other flat surface. It should be positioned so that the microphone is 4' to 8' from the area of desired coverage.

MICROPHONE CONNECTION:

A 3-pin terminal block is located on the back of the microphone housing, marked A, B, C.

A represents +12 Vdc Power
B represents Audio Output
C represents Ground

If using West Penn 452 or equivalent with same color code, connect:

1. Red wire (12 Vdc) connects to terminal A of microphone terminal block
2. Black wire (audio out) connects to terminal B of microphone terminal block
3. Bare wire (ground) connects to terminal C of microphone terminal block

CONNECTING VERIFACT® BGC MICROPHONE TO A LOUROE BASE STATION OR AUDIO INTERFACE ADAPTER

All Louroe audio base stations and Interface Adapters have corresponding terminal blocks marked A, B, C. Connect other end of cable as follows:

1. Red wire from microphone connects to pin A of Base Station (12Vdc)
2. Black wire from microphone connects to pin B of Base Station (Audio Output)
3. Bare wire from microphone connects to pin C of Base Station (Ground)

CONNECTING VERIFACT® BGC MICROPHONE TO OTHER AUDIO DEVICES.

If a Louroe audio base station is not used and microphone is being connected directly to another receiver from other manufacturers, 12 Vdc power must be applied to terminals A and C. (A is positive, C is negative). Terminals B and C of microphone (C is common) go to the "Audio In" or "Line in" of the audio source. We recommend shielded cable connections for terminal B and C (See last page for interconnection diagram)

INSTALLATION TIP: If area to be monitored for audio is noisy or has background disturbances, the microphone should be positioned close to the subject (4' - 8') if possible. Also, the microphone output can be lowered by adjusting the gain control potentiometer. Rotating clockwise will increase the gain; counterclockwise decreases the gain. The factory setting is 0dB output.

INSTALLATION TIPS

1. Use 2 Cond 22AWG overall shielded audio cable only. West Penn 452, Belden 8451 or equivalent. UNSHIELDED CABLE IS NOT SATISFACTORY FOR SOUND SYSTEMS.
2. When used at a cash register checkout, microphone should be installed closer to the customer rather than the cash register, as the drawer sound could dominate the recording. It should be installed closest to the area to be monitored and documented.
3. Avoid installing microphone near air vents, air conditioners, fans and other equipment that generate high sound and air pressure.
4. If microphone is installed in a police interview room, room should be conditioned with any type of carpeting, acoustical ceiling tiles, acoustical foam, etc. to reduce echo. This will enhance the quality of live and recorded audio.
5. The APR-1 and microphone should have a barrier or solid wall between them in order to avoid audio feedback, especially when they are in close proximity to each other. If no barrier, microphone should be at least 25' from APR-1 to avoid acoustical feedback.

INSTALLATION AND OPERATING INSTRUCTIONS

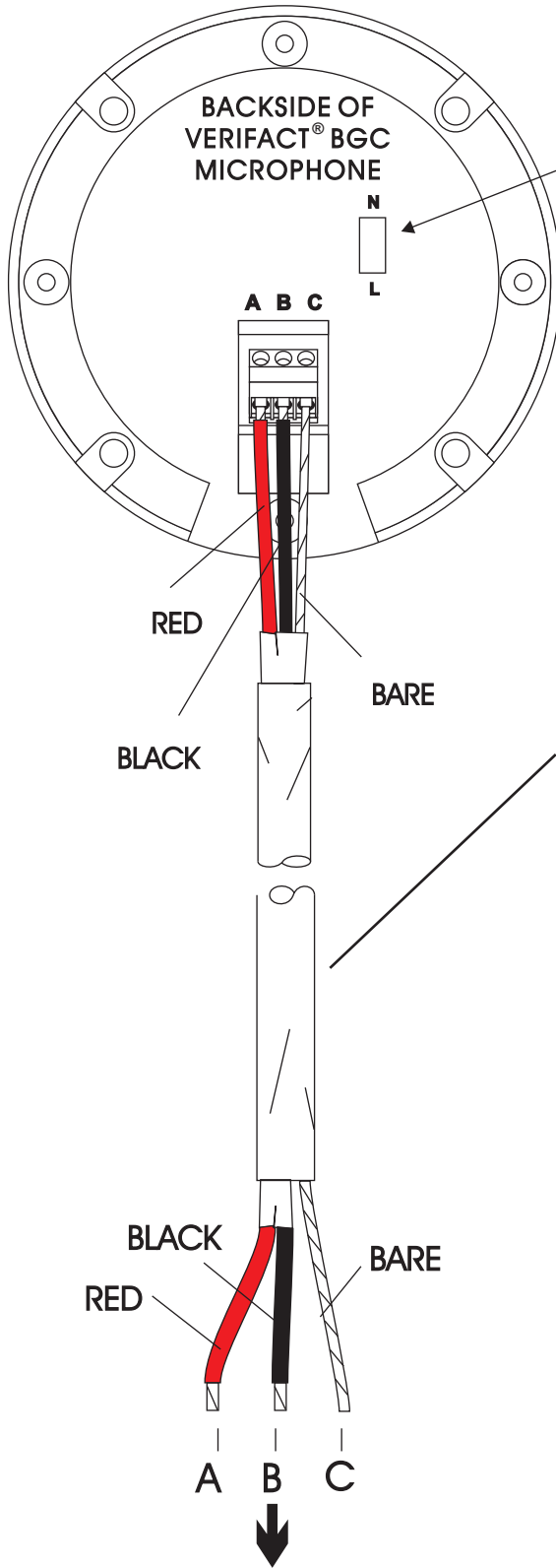

MICROPHONE GAIN ADJUSTMENT
Located inside the opening is an audio output gain potentiometer. Microphone is always shipped with a 0dB output. If it's necessary to change the gain of the microphone, insert a small screwdriver inside the opening and rotate the potentiometer clockwise to increase or counterclockwise to decrease.

WIRING REQUIREMENTS
2 Conductor **shielded** cable, 22 gauge with a 24 gauge drain wire.
NOTE: Unshielded cable is not satisfactory for audio systems.
West Penn 452 or equivalent



A = +12Vdc (RED)
B = Audio (BLACK)
C = Ground (BARE)

TO LOUOE™ BASE STATIONS AND AUDIO INTERFACES
OR
OTHER AUDIO RECEIVERS AND RECORDERS

INSTALLATION AND OPERATING INSTRUCTIONS

CONNECTING A LOUROE MICROPHONE DIRECTLY TO AN IP CAMERA, ENCODER OR DVR WITH 3.5mm MONO AUDIO INPUT

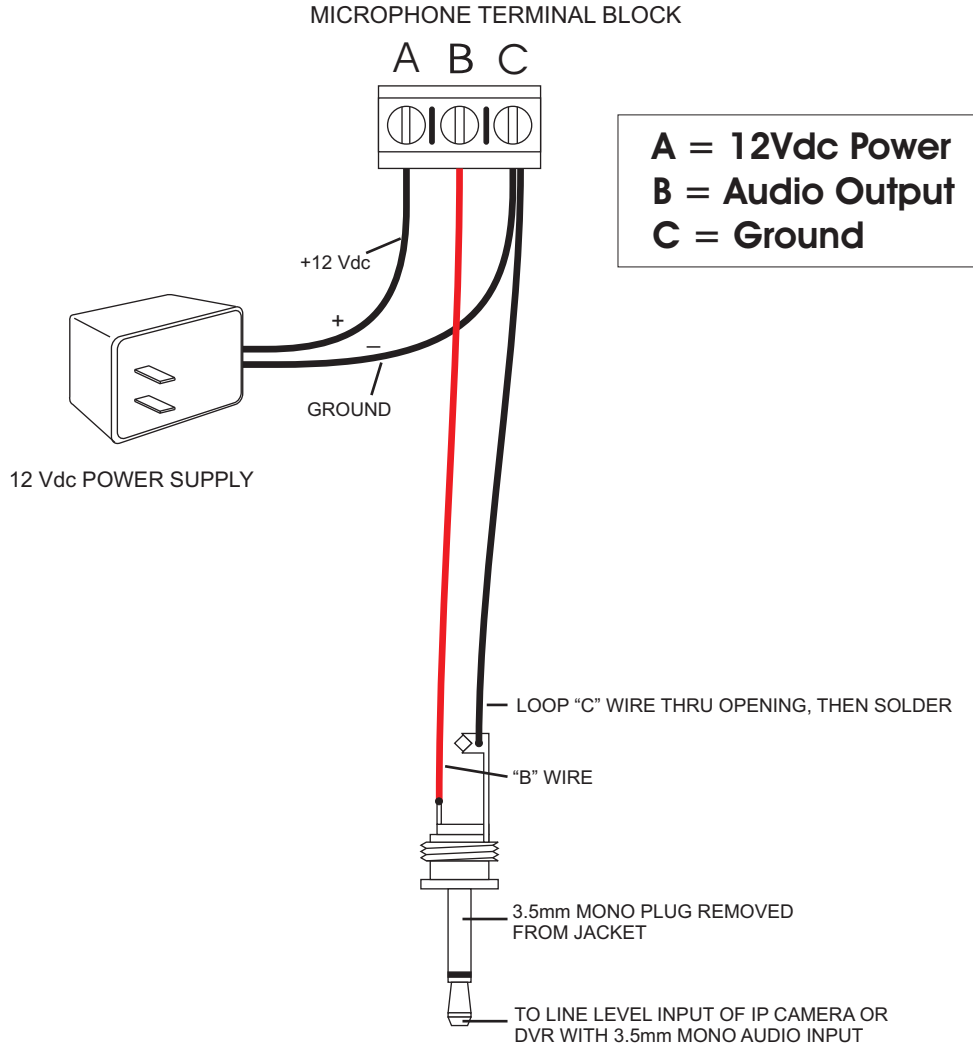

OTHER PLUGS WIRING CONFIGURATION

